

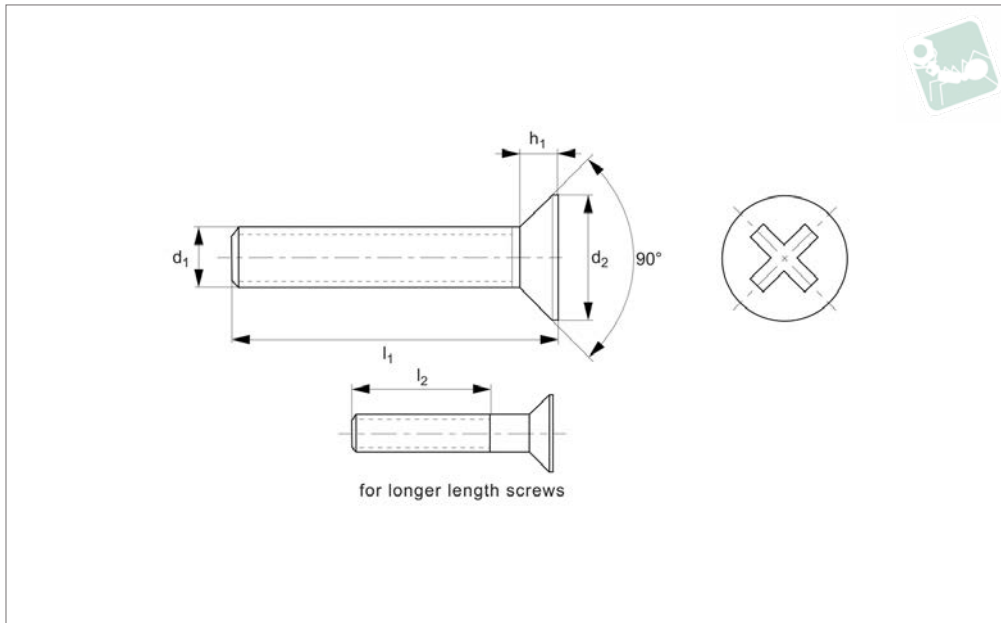

Cross Recessed Csk Screws

flat head screws, DIN 965 H, 7075

Aluminium



A0019.A7

ALUMINIUM

Material

Aluminium high tensile.

screw lengths the threads goes all the way to the head of the screw (i.e. $l_1 = l_2$) less 2.5 thread pitches.

portion $l_2 < l_1$.

Technical Notes

To DIN 965 H, ISO 7046. For the majority of

For longer length screws the threaded

See technical page for tightening torques.

Order No.	Thread	l_1	d_2	l_2	h_1	Size	Material	Finish
A0019.030-016	M 3	16	5.6	-	1.65	PH-1	Aluminium	clear anodised
A0019.030-020	M 3	20	5.6	-	1.65	PH-1	Aluminium	clear anodised
A0019.030-025	M 3	25	5.6	19	1.65	PH-1	Aluminium	clear anodised
A0019.040-016	M 4	16	7.5	-	2.2	PH-2	Aluminium	clear anodised
A0019.040-025	M 4	25	7.5	-	2.2	PH-2	Aluminium	clear anodised
A0019.050-012	M 5	12	9.2	-	2.5	PH-2	Aluminium	clear anodised
A0019.050-016	M 5	16	9.2	-	2.5	PH-2	Aluminium	clear anodised
A0019.050-020	M 5	20	9.2	-	2.5	PH-2	Aluminium	clear anodised
A0019.060-016	M 6	16	11	-	3.0	PH-3	Aluminium	clear anodised
A0019.060-020	M 6	20	11	-	3.0	PH-3	Aluminium	clear anodised
A0019.060-025	M 6	25	11	-	3.0	PH-3	Aluminium	clear anodised
A0019.060-030	M 6	30	11	-	3.0	PH-3	Aluminium	clear anodised
A0019.060-040	M 6	40	11	28	3.0	PH-3	Aluminium	clear anodised
A0019.060-050	M 6	50	11	28	3.0	PH-3	Aluminium	clear anodised
A0019.080-020	M 8	20	14.5	-	4.0	PH-4	Aluminium	clear anodised
A0019.080-050	M 8	50	14.5	34	4.0	PH-4	Aluminium	clear anodised