

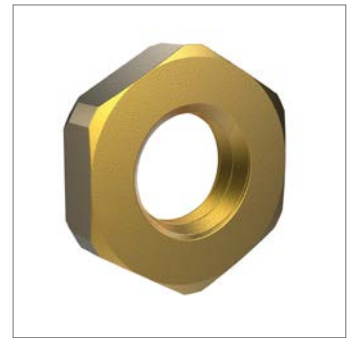

Hexagon thin nuts

unchamfered, DIN 439

Brass

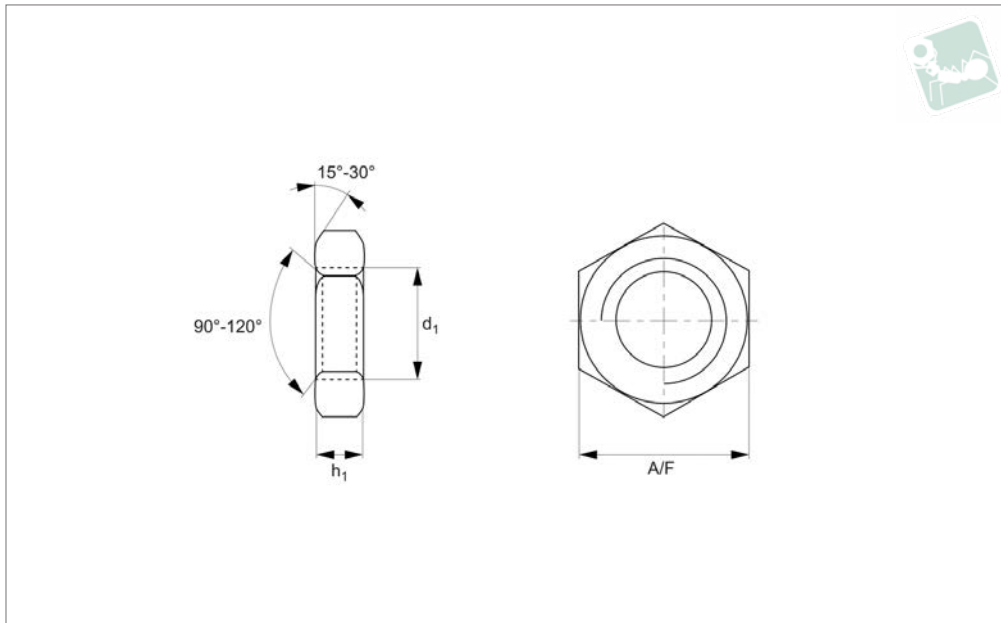

B0507.B0

BRASS

Material

Brass, Cu3 (CuZn39Pb3).

Technical Notes

To DIN 439. Standard metric coarse pitch threads.

Order No.	Thread	h min.	A/F	Material	Finish
B0507.020	M 2	0.95	4.0	Brass	unfinished
B0507.025	M2,5	1.35	5.0	Brass	unfinished
B0507.030	M 3	1.55	5.5	Brass	unfinished
B0507.040	M 4	1.95	7.0	Brass	unfinished
B0507.050	M 5	2.45	8.0	Brass	unfinished
B0507.060	M 6	2.9	10.0	Brass	unfinished
B0507.080	M 8	3.7	13.0	Brass	unfinished
B0507.100	M10	4.7	17.0	Brass	unfinished
B0507.120	M12	5.7	19.0	Brass	unfinished
B0507.140	M14	6.42	22.0	Brass	unfinished
B0507.160	M16	7.42	24.0	Brass	unfinished
B0507.180	M18	8.42	27.0	Brass	unfinished
B0507.200	M20	9.1	30.0	Brass	unfinished
B0507.220	M22	9.9	34.0	Brass	unfinished
B0507.240	M24	10.9	36.0	Brass	unfinished
B0507.270	M27	12.4	41.0	Brass	unfinished
B0507.300	M30	13.9	46.0	Brass	unfinished
B0507.330	M33	15.4	50.0	Brass	unfinished
B0507.360	M36	16.9	55.0	Brass	unfinished
B0507.420	M42	19.7	55.0	Brass	unfinished