

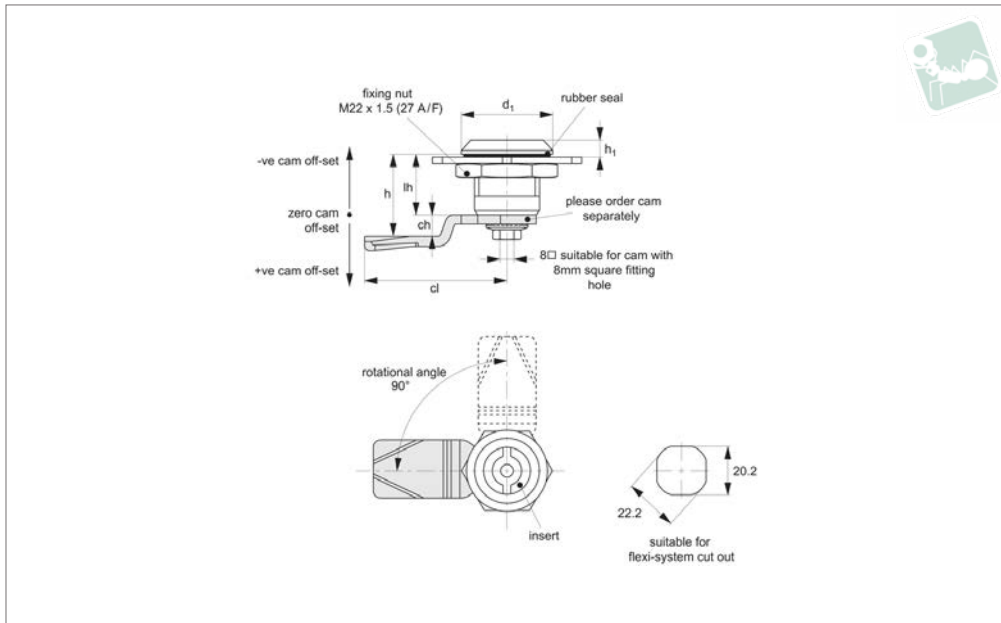

Cam Latches - Flexi-System

insert driver - fixed grip - stainless steel

Latches



CC0420

LATCHES

Material

Body & Insert: stainless steel, AISI 304.
Insert fitted with O'ring to achieve IP54 rating. Internal spring provides 1,5mm torsion.

Supplied with: Nut: stainless steel.
Sealing washer: PU & Rubber.

Not supplied: CAM nor KEY - order separately.

Technical Notes

Order cam and key separately.

Cams: see suitable cam CC0022. Select „without projection“ cam type.

Dimensions ch and cl relate to cam. Use formula to calculate ch (required cam off-set), and refer to cam selection chart;

ch = h - lh where;

ch = required cam off-set/height.

h = grip length (distance between inside of latch face and front of cam).

lh = body length of cam latch/lock to be used (see product table below).

Keys: see CC0010.

Rods & Guides: to achieve 3-point latching - CC0340, CC0350, CC0355.

Order No.	Insert driver	d ₁	h ₁	lh
CC0420.M0020	Square 8	28	6	18
CC0420.M0040	Triangle 7	28	6	18
CC0420.M0050	Triangle 8	28	6	18
CC0420.M0060	3mm Double Bit	28	6	18
CC0420.M0070	4mm Double Bit	28	6	18

Available insert drivers:

Square 8	Triangle 7	Triangle 8	3mm Double Bit	4mm Double Bit