

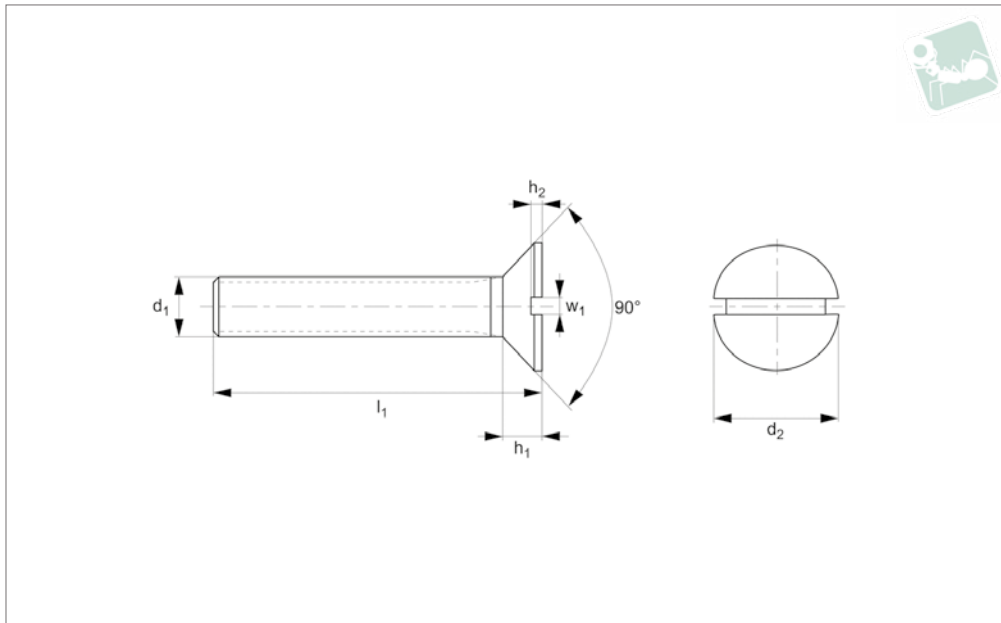

Slot Countersunk Screw

DIN 963

Nylon



N0013.11N

NYLON

Material

Nylon 66 (PA 6/66), standard. Natural or black.

Technical Notes

DIN norms were created for metal parts, the dimensions of our plastic DIN equivalents are close to the norm but do not

follow the strict tolerances typically relevant to metal parts.

Many Nylon parts are available in dyed black, this subject to a minimum value and process charge, please contact us for further details.

Dyed black colour is not long term UV

stable. Nylon parts offer good electrical insulation, is resistant to corrosion and most dilute acids.

Nylon protects work surfaces and absorbs shocks and vibrations.

Order No.	d ₁	l ₁	d ₂	h ₁	h ₂	w ₁	Material	Grade	Finish	To standard
11N.020.0040.OA	M 2	4	4.4	1.2	0.4	0.5	PA 6/66	Std	Natural	-
11N.020.0050.OA	M 2	5	4.4	1.2	0.4	0.5	PA 6/66	Std	Natural	-
11N.020.0060.OA	M 2	6	4.4	1.2	0.4	0.5	PA 6/66	Std	Natural	-
11N.020.0080.OA	M 2	8	4.4	1.2	0.4	0.5	PA 6/66	Std	Natural	-
11N.020.0080.OB	M 2	8	4.4	1.2	0.4	0.5	PA 6/66	Std	Black	-
11N.020.0100.OA	M 2	10	4.4	1.2	0.4	0.5	PA 6/66	Std	Natural	-
11N.020.0110.OA	M 2	11	4.4	1.2	0.4	0.5	PA 6/66	Std	Natural	-
11N.020.0120.OA	M 2	12	4.4	1.2	0.4	0.5	PA 6/66	Std	Natural	-
11N.020.0160.OA	M 2	16	4.4	1.2	0.4	0.5	PA 6/66	Std	Natural	-
11N.020.0200.OA	M 2	20	4.4	1.2	0.4	0.5	PA 6/66	Std	Natural	-
11N.020.0250.OA	M 2	25	4.4	1.2	0.4	0.5	PA 6/66	Std	Natural	-
11N.025.0040.OA	M2,5	4	5.5	1.5	0.5	0.5	PA 6/66	Std	Natural	-
11N.025.0050.OA	M2,5	5	5.5	1.5	0.5	0.5	PA 6/66	Std	Natural	-
11N.025.0060.OA	M2,5	6	5.5	1.5	0.5	0.5	PA 6/66	Std	Natural	-
11N.025.0080.OA	M2,5	8	5.5	1.5	0.5	0.5	PA 6/66	Std	Natural	-
11N.025.0100.OA	M2,5	10	5.5	1.5	0.5	0.5	PA 6/66	Std	Natural	-
11N.025.0100.OB	M2,5	10	5.5	1.5	0.5	0.5	PA 6/66	Std	Black	-
11N.025.0120.OA	M2,5	12	5.5	1.5	0.5	0.5	PA 6/66	Std	Natural	-
11N.025.0160.OA	M2,5	16	5.5	1.5	0.5	0.5	PA 6/66	Std	Natural	-
11N.025.0160.OB	M2,5	16	5.5	1.5	0.5	0.5	PA 6/66	Std	Black	-
11N.025.0200.OA	M2,5	20	5.5	1.5	0.5	0.5	PA 6/66	Std	Natural	-
11N.025.0250.OA	M2,5	25	5.5	1.5	0.5	0.5	PA 6/66	Std	Natural	-
11N.030.0050.OA	M 3	5	6.3	1.7	0.6	0.8	PA 6/66	Std	Natural	-
11N.030.0050.OB	M 3	5	6.3	1.7	0.6	0.8	PA 6/66	Std	Black	-
11N.030.0060.OA	M 3	6	6.3	1.7	0.6	0.8	PA 6/66	Std	Natural	-
11N.030.0060.OB	M 3	6	6.3	1.7	0.6	0.8	PA 6/66	Std	Black	-
11N.030.0080.OA	M 3	8	6.3	1.7	0.6	0.8	PA 6/66	Std	Natural	-
11N.030.0080.OB	M 3	8	6.3	1.7	0.6	0.8	PA 6/66	Std	Black	-
11N.030.0100.OA	M 3	10	6.3	1.7	0.6	0.8	PA 6/66	Std	Natural	-
11N.030.0100.OB	M 3	10	6.3	1.7	0.6	0.8	PA 6/66	Std	Black	-
11N.030.0120.OA	M 3	12	6.3	1.7	0.6	0.8	PA 6/66	Std	Natural	-



Order No.	d ₁	l ₁	d ₂	h ₁	h ₂	w ₁	Material	Grade	Finish	To standard
11N.030.0120.OB	M 3	12	6.3	1.7	0.6	0.8	PA 6/66	Std	Black	-
11N.030.0150.OA	M 3	15	6.3	1.7	0.6	0.8	PA 6/66	Std	Natural	-
11N.030.0160.OA	M 3	16	6.3	1.7	0.6	0.8	PA 6/66	Std	Natural	-
11N.030.0160.OB	M 3	16	6.3	1.7	0.6	0.8	PA 6/66	Std	Black	-
11N.030.0200.OA	M 3	20	6.3	1.7	0.6	0.8	PA 6/66	Std	Natural	-
11N.030.0200.OB	M 3	20	6.3	1.7	0.6	0.8	PA 6/66	Std	Black	-
11N.030.0250.OA	M 3	25	6.3	1.7	0.6	0.8	PA 6/66	Std	Natural	-
11N.030.0250.OB	M 3	25	6.3	1.7	0.6	0.8	PA 6/66	Std	Black	-
11N.030.0300.OA	M 3	30	6.3	1.7	0.6	0.8	PA 6/66	Std	Natural	-
11N.030.0420.OA	M 3	42	6.3	1.7	0.6	0.8	PA 6/66	Std	Natural	-
11N.030.0450.OA	M 3	45	5.6	1.65	0.6	0.8	PA 6/66	Std	Natural	-
11N.030.0550.OA	M 3	55	5.6	1.65	0.6	0.8	PA 6/66	Std	Natural	-
11N.035.0050.OA	M3,5	5	8.2	2.3	0.9	1.0	PA 6/66	Std	Natural	-
11N.035.0060.OA	M3,5	6	8.2	2.3	0.9	1.0	PA 6/66	Std	Natural	-
11N.035.0080.OA	M3,5	8	8.2	2.3	0.9	1.0	PA 6/66	Std	Natural	-
11N.035.0100.OA	M3,5	10	8.2	2.3	0.9	1.0	PA 6/66	Std	Natural	-
11N.035.0160.OA	M3,5	16	8.2	2.3	0.9	1.0	PA 6/66	Std	Natural	-
11N.035.0200.OA	M3,5	20	8.2	2.3	0.9	1.0	PA 6/66	Std	Natural	-
11N.035.0250.OA	M3,5	25	8.2	2.3	0.9	1.0	PA 6/66	Std	Natural	-
11N.035.0350.OA	M3,5	35	8.2	2.3	0.9	1.0	PA 6/66	Std	Natural	-
11N.040.0060.OA	M 4	6	9.4	2.7	1.0	1.2	PA 6/66	Std	Natural	-
11N.040.0060.OB	M 4	6	9.4	2.7	1.0	1.2	PA 6/66	Std	Black	-
11N.040.0080.OA	M 4	8	9.4	2.7	1.0	1.2	PA 6/66	Std	Natural	-
11N.040.0100.OA	M 4	10	9.4	2.7	1.0	1.2	PA 6/66	Std	Natural	-
11N.040.0100.OB	M 4	10	9.4	2.7	1.0	1.2	PA 6/66	Std	Black	-
11N.040.0120.OA	M 4	12	9.4	2.7	1.0	1.2	PA 6/66	Std	Natural	-
11N.040.0120.OB	M 4	12	9.4	2.7	1.0	1.2	PA 6/66	Std	Black	-
11N.040.0160.OA	M 4	16	9.4	2.7	1.0	1.2	PA 6/66	Std	Natural	-
11N.040.0200.OA	M 4	20	9.4	2.7	1.0	1.2	PA 6/66	Std	Natural	-
11N.040.0200.OB	M 4	20	9.4	2.7	1.0	1.2	PA 6/66	Std	Black	-
11N.040.0250.OA	M 4	25	9.4	2.7	1.0	1.2	PA 6/66	Std	Natural	-
11N.040.0250.OB	M 4	25	9.4	2.7	1.0	1.2	PA 6/66	Std	Black	-
11N.040.0300.OA	M 4	30	9.4	2.7	1.0	1.2	PA 6/66	Std	Natural	-
11N.040.0300.OB	M 4	30	9.4	2.7	1.0	1.2	PA 6/66	Std	Black	-
11N.040.0350.OA	M 4	35	9.4	2.7	1.0	1.2	PA 6/66	Std	Natural	-
11N.050.0060.OA	M 5	6	10.4	2.7	1.1	1.2	PA 6/66	Std	Natural	-
11N.050.0080.OA	M 5	8	10.4	2.7	1.1	1.2	PA 6/66	Std	Natural	-
11N.050.0080.OB	M 5	8	10.4	2.7	1.1	1.2	PA 6/66	Std	Black	-
11N.050.0100.OA	M 5	10	10.4	2.7	1.1	1.2	PA 6/66	Std	Natural	-
11N.050.0100.OB	M 5	10	10.4	2.7	1.1	1.2	PA 6/66	Std	Black	-
11N.050.0120.OA	M 5	12	10.4	2.7	1.1	1.2	PA 6/66	Std	Natural	-
11N.050.0160.OA	M 5	16	10.4	2.7	1.1	1.2	PA 6/66	Std	Natural	-
11N.050.0160.OB	M 5	16	10.4	2.7	1.1	1.2	PA 6/66	Std	Black	-
11N.050.0200.OA	M 5	20	10.4	2.7	1.1	1.2	PA 6/66	Std	Natural	-
11N.050.0200.OB	M 5	20	10.4	2.7	1.1	1.2	PA 6/66	Std	Black	-
11N.050.0250.OA	M 5	25	10.4	2.7	1.1	1.2	PA 6/66	Std	Natural	-
11N.050.0300.OA	M 5	30	10.4	2.7	1.1	1.2	PA 6/66	Std	Natural	-
11N.050.0400.OA	M 5	40	10.4	2.7	1.1	1.2	PA 6/66	Std	Natural	-
11N.060.0080.OA	M 6	8	12.6	3.3	1.2	1.6	PA 6/66	Std	Natural	-
11N.060.0100.OA	M 6	10	12.6	3.3	1.2	1.6	PA 6/66	Std	Natural	-
11N.060.0120.OA	M 6	12	12.6	3.3	1.2	1.6	PA 6/66	Std	Natural	-
11N.060.0160.OA	M 6	16	12.6	3.3	1.2	1.6	PA 6/66	Std	Natural	-
11N.060.0200.OA	M 6	20	12.6	3.3	1.2	1.6	PA 6/66	Std	Natural	-
11N.060.0200.OB	M 6	20	12.6	3.3	1.2	1.6	PA 6/66	Std	Black	-
11N.060.0250.OA	M 6	25	12.6	3.3	1.2	1.6	PA 6/66	Std	Natural	-
11N.060.0300.OA	M 6	30	12.6	3.3	1.2	1.6	PA 6/66	Std	Natural	-
11N.060.0300.OB	M 6	30	11.0	3.0	1.2	1.6	PA 6/66	Std	Black	-
11N.060.0350.OA	M 6	35	12.6	3.3	1.2	1.6	PA 6/66	Std	Natural	-
11N.060.0400.OA	M 6	40	12.6	3.3	1.2	1.6	PA 6/66	Std	Natural	-
11N.060.0450.OA	M 6	45	12.6	3.3	1.2	1.6	PA 6/66	Std	Natural	-
11N.060.0450.OB	M 6	45	12.6	3.3	1.2	1.6	PA 6/66	Std	Black	-
11N.060.0500.OA	M 6	50	12.6	3.3	1.2	1.6	PA 6/66	Std	Natural	-
11N.060.0500.OB	M 6	50	12.6	3.3	1.2	1.6	PA 6/66	Std	Black	-
11N.060.0600.OA	M 6	60	12.6	3.3	1.2	1.6	PA 6/66	Std	Natural	-
11N.060.0650.OA	M 6	60	12.6	3.3	1.2	1.6	PA 6/66	Std	Natural	-
11N.080.0100.OAD	M 8	10	14.5	4.0	1.6	2.0	PA 6/66	Std	Natural	DIN 963
11N.080.0120.OAD	M 8	12	14.5	4.0	1.6	2.0	PA 6/66	Std	Natural	DIN 963
11N.080.0150.OAD	M 8	15	14.5	4.0	1.6	2.0	PA 6/66	Std	Natural	DIN 963
11N.080.0160.OA	M 8	16	17.3	4.6	1.8	2.3	PA 6/66	Std	Natural	-



Slot Countersunk Screw

DIN 963

Nylon

Order No.	d ₁	l ₁	d ₂	h ₁	h ₂	w ₁	Material	Grade	Finish	To standard
11N.080.0170.0AD	M 8	17	14.5	4.0	1.6	2.0	PA 6/66	Std	Natural	DIN 963
11N.080.0200.0A	M 8	20	17.3	4.6	1.8	2.3	PA 6/66	Std	Natural	-
11N.080.0200.0AD	M 8	20	14.5	4.0	1.6	2.0	PA 6/66	Std	Natural	DIN 963
11N.080.0250.0A	M 8	25	17.3	4.6	1.8	2.3	PA 6/66	Std	Natural	-
11N.080.0250.0AD	M 8	25	14.5	4.0	1.6	2.0	PA 6/66	Std	Natural	DIN 963
11N.080.0250.0B	M 8	25	17.3	4.6	1.8	2.3	PA 6/66	Std	Black	-
11N.080.0300.0A	M 8	30	17.3	4.6	1.8	2.3	PA 6/66	Std	Natural	-
11N.080.0300.0AD	M 8	30	14.5	4.0	1.6	2.0	PA 6/66	Std	Natural	DIN 963
11N.080.0300.0B	M 8	30	17.3	4.6	1.8	2.3	PA 6/66	Std	Black	-
11N.080.0350.0A	M 8	35	17.3	4.6	1.8	2.3	PA 6/66	Std	Natural	-
11N.080.0350.0AD	M 8	35	14.5	4.0	1.6	2.0	PA 6/66	Std	Natural	DIN 963
11N.080.0400.0A	M 8	40	17.3	4.6	1.8	2.3	PA 6/66	Std	Natural	-
11N.080.0400.0AD	M 8	40	14.5	4.0	1.6	2.0	PA 6/66	Std	Natural	DIN 963
11N.080.0450.0A	M 8	45	14.5	4.0	1.6	2.0	PA 6/66	Std	Black	DIN 963
11N.080.0450.0AD	M 8	45	14.5	4.0	1.6	2.0	PA 6/66	Std	Natural	DIN 963
11N.080.0500.0A	M 8	50	17.3	4.6	1.8	2.3	PA 6/66	Std	Natural	-
11N.080.0500.0AD	M 8	50	14.5	4.0	1.6	2.0	PA 6/66	Std	Natural	DIN 963
11N.080.0500.0B	M 8	50	17.3	4.6	1.8	2.3	PA 6/66	Std	Black	-
11N.080.0550.0AD	M 8	55	14.5	4.0	1.6	2.0	PA 6/66	Std	Natural	DIN 963
11N.080.0600.0A	M 8	60	17.3	4.6	1.8	2.3	PA 6/66	Std	Natural	-
11N.080.0650.0AD	M 8	65	14.5	4.0	1.6	2.0	PA 6/66	Std	Natural	DIN 963
11N.080.0700.0A	M 8	70	17.3	4.6	1.8	2.3	PA 6/66	Std	Natural	-
11N.080.0750.0AD	M 8	75	14.5	4.0	1.6	2.0	PA 6/66	Std	Natural	DIN 963
11N.080.0850.0AD	M 8	85	14.5	4.0	1.6	2.0	PA 6/66	Std	Natural	DIN 963
11N.100.0100.0AD	M10	10	18.0	5.0	2.0	2.5	PA 6/66	Std	Natural	DIN 963
11N.100.0120.0AD	M10	12	18.0	5.0	2.0	2.5	PA 6/66	Std	Natural	DIN 963
11N.100.0150.0AD	M10	15	18.0	5.0	2.0	2.5	PA 6/66	Std	Natural	DIN 963
11N.100.0170.0AD	M10	17	18.0	5.0	2.0	2.5	PA 6/66	Std	Natural	DIN 963
11N.100.0200.0A	M10	20	20.0	5.0	2.0	2.5	PA 6/66	Std	Natural	-
11N.100.0200.0AD	M10	20	18.0	5.0	2.0	2.5	PA 6/66	Std	Natural	DIN 963
11N.100.0200.0B	M10	20	20.0	5.0	2.0	2.5	PA 6/66	Std	Black	-
11N.100.0250.0A	M10	25	20.0	5.0	2.0	2.5	PA 6/66	Std	Natural	-
11N.100.0250.0AD	M10	25	18.0	5.0	2.0	2.5	PA 6/66	Std	Natural	DIN 963
11N.100.0300.0A	M10	30	20.0	5.0	2.0	2.5	PA 6/66	Std	Natural	-
11N.100.0300.0AD	M10	30	18.0	5.0	2.0	2.5	PA 6/66	Std	Natural	DIN 963
11N.100.0300.0B	M10	30	20.0	5.0	2.0	2.5	PA 6/66	Std	Black	-
11N.100.0350.0A	M10	35	20.0	5.0	2.0	2.5	PA 6/66	Std	Natural	-
11N.100.0350.0AD	M10	35	18.0	5.0	2.0	2.5	PA 6/66	Std	Natural	DIN 963
11N.100.0400.0A	M10	40	20.0	5.0	2.0	2.5	PA 6/66	Std	Natural	-
11N.100.0400.0AD	M10	40	18.0	5.0	2.0	2.5	PA 6/66	Std	Natural	DIN 963
11N.100.0450.0AD	M10	45	18.0	5.0	2.0	2.5	PA 6/66	Std	Natural	DIN 963
11N.100.0500.0A	M10	50	20.0	5.0	2.0	2.5	PA 6/66	Std	Natural	-
11N.100.0500.0AD	M10	50	18.0	5.0	2.0	2.5	PA 6/66	Std	Natural	DIN 963
11N.100.0550.0AD	M10	55	18.0	5.0	2.0	2.5	PA 6/66	Std	Natural	DIN 963
11N.100.0600.0A	M10	60	20.0	5.0	2.0	2.5	PA 6/66	Std	Natural	-
11N.100.0650.0AD	M10	65	18.0	5.0	2.0	2.5	PA 6/66	Std	Natural	DIN 963
11N.100.0750.0A	M10	75	20.0	5.0	2.0	2.5	PA 6/66	Std	Natural	-
11N.100.0750.0AD	M10	75	18.0	5.0	2.0	2.5	PA 6/66	Std	Natural	DIN 963
11N.100.0850.0AD	M10	85	18.0	5.0	2.0	2.5	PA 6/66	Std	Natural	DIN 963
11N.120.0200.0A	M12	20	22.0	6.0	2.4	3.0	PA 6/66	Std	Natural	DIN 963
11N.120.0250.0A	M12	25	22.0	6.0	2.4	3.0	PA 6/66	Std	Natural	DIN 963
11N.120.0300.0A	M12	30	22.0	6.0	2.4	3.0	PA 6/66	Std	Natural	DIN 963
11N.120.0350.0A	M12	35	22.0	6.0	2.4	3.0	PA 6/66	Std	Natural	DIN 963
11N.120.0450.0A	M12	45	22.0	6.0	2.4	3.0	PA 6/66	Std	Natural	DIN 963
11N.120.0500.0A	M12	50	22.0	6.0	2.4	3.0	PA 6/66	Std	Natural	DIN 963
11N.120.0500.0B	M12	50	22.0	6.0	2.4	3.0	PA 6/66	Std	Black	DIN 963
11N.120.0600.0A	M12	60	22.0	6.0	2.4	3.0	PA 6/66	Std	Natural	DIN 963
11N.120.0650.0A	M12	65	22.0	6.0	2.4	3.0	PA 6/66	Std	Natural	DIN 963
11N.120.0700.0A	M12	70	22.0	6.0	2.4	3.0	PA 6/66	Std	Natural	-
11N.120.0750.0A	M12	75	22.0	6.0	2.4	3.0	PA 6/66	Std	Natural	DIN 963
11N.120.0950.0A	M12	95	22.0	6.0	2.4	3.0	PA 6/66	Std	Natural	-
11N.160.0400.0A	M16	40	29.0	8.0	4.0	4.0	PA 6/66	Std	Natural	-
11N.160.0500.0A	M16	50	29.0	8.0	4.0	4.0	PA 6/66	Std	Natural	-

NOTEN