

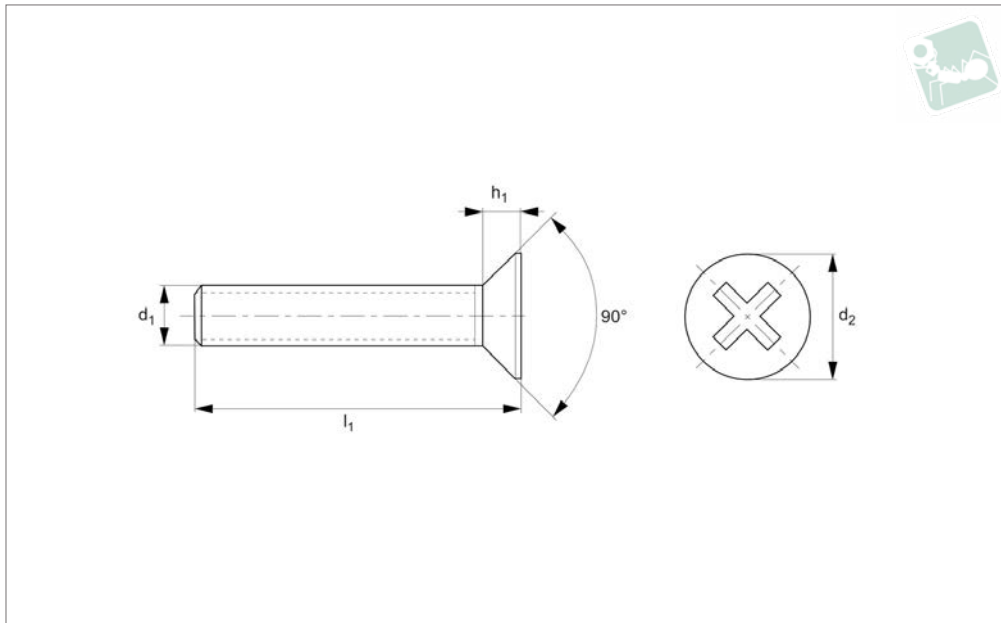

Pozi Countersunk Screw

DIN 965

Nylon



N0019.19N

NYLON

Material

Nylon 66 (PA 6/66), standard. Natural or black.

Technical Notes

DIN norms were created for metal parts, the dimensions of our plastic DIN equivalents are close to the norm but do not

follow the strict tolerances typically relevant to metal parts.

Many Nylon parts are available in dyed black, this subject to a minimum value and process charge, please contact us for further details.

Dyed black colour is not long term UV

stable. Nylon parts offer good electrical insulation, is resistant to corrosion and most dilute acids.

Nylon protects work surfaces and absorbs shocks and vibrations.

Order No.	d ₁	l ₁	d ₂	h ₁	Material	Grade	Finish	To standard
19N.025.0040.0A	M2,5	4	4.7	1.5	PA-6/66	Std.	Natural	-
19N.025.0050.0A	M2,5	5	4.7	1.5	PA-6/66	Std.	Natural	-
19N.025.0060.0A	M2,5	6	4.7	1.5	PA-6/66	Std.	Natural	-
19N.025.0080.0A	M2,5	8	4.7	1.5	PA-6/66	Std.	Natural	-
19N.025.0100.0A	M2,5	10	4.7	1.5	PA-6/66	Std.	Natural	-
19N.025.0120.0A	M2,5	12	4.7	1.5	PA-6/66	Std.	Natural	-
19N.025.0160.0A	M2,5	16	4.7	1.5	PA-6/66	Std.	Natural	-
19N.025.0200.0A	M2,5	20	4.7	1.5	PA-6/66	Std.	Natural	-
19N.025.0250.0A	M2,5	25	4.7	1.5	PA-6/66	Std.	Natural	-
19N.030.0050.0A	M 3	5	5.6	1.6	PA-6/66	Std.	Natural	-
19N.030.0060.0A	M 3	6	5.6	1.6	PA-6/66	Std.	Natural	-
19N.030.0080.0A	M 3	8	5.6	1.6	PA-6/66	Std.	Natural	-
19N.030.0100.0A	M 3	10	5.6	1.6	PA-6/66	Std.	Natural	-
19N.030.0120.0A	M 3	12	5.6	1.6	PA-6/66	Std.	Natural	-
19N.030.0160.0A	M 3	16	5.6	1.6	PA-6/66	Std.	Natural	-
19N.030.0200.0A	M 3	20	5.6	1.6	PA-6/66	Std.	Natural	-
19N.030.0250.0A	M 3	25	5.6	1.6	PA-6/66	Std.	Natural	-
19N.035.0050.0A	M3,5	5	8.2	2.3	PA-6/66	Std.	Natural	-
19N.035.0060.0A	M3,5	6	8.2	2.3	PA-6/66	Std.	Natural	-
19N.035.0080.0A	M3,5	8	8.2	2.3	PA-6/66	Std.	Natural	-
19N.035.0100.0A	M3,5	10	8.2	2.3	PA-6/66	Std.	Natural	-
19N.035.0120.0A	M3,5	12	8.2	2.3	PA-6/66	Std.	Natural	-
19N.035.0160.0A	M3,5	16	8.2	2.3	PA-6/66	Std.	Natural	-
19N.035.0200.0A	M3,5	20	8.2	2.3	PA-6/66	Std.	Natural	-
19N.035.0250.0A	M3,5	25	8.2	2.3	PA-6/66	Std.	Natural	-
19N.035.0350.0A	M3,5	35	8.2	2.3	PA-6/66	Std.	Natural	-
19N.040.0060.0A	M 4	6	7.5	2.2	PA-6/66	Std.	Natural	-
19N.040.0080.0A	M 4	8	7.5	2.2	PA-6/66	Std.	Natural	-
19N.040.0100.0A	M 4	10	7.5	2.2	PA-6/66	Std.	Natural	-
19N.040.0120.0A	M 4	12	7.5	2.2	PA-6/66	Std.	Natural	-
19N.040.0160.0A	M 4	16	7.5	2.2	PA-6/66	Std.	Natural	-



Order No.	d ₁	l ₁	d ₂	h ₁	Material	Grade	Finish	To standard
19N.050.0060.OA	M 5	6	9.2	2.5	PA-6/66	Std.	Natural	-
19N.050.0080.OA	M 5	8	9.2	2.5	PA-6/66	Std.	Natural	-
19N.050.0100.OA	M 5	10	9.2	2.5	PA-6/66	Std.	Natural	-
19N.050.0120.OA	M 5	12	9.2	2.5	PA-6/66	Std.	Natural	-
19N.050.0160.OA	M 5	16	9.2	2.5	PA-6/66	Std.	Natural	-
19N.050.0200.OA	M 5	20	9.2	2.5	PA-6/66	Std.	Natural	-
19N.050.0250.OA	M 5	25	9.2	2.5	PA-6/66	Std.	Natural	-
19N.050.0300.OA	M 5	30	9.2	2.5	PA-6/66	Std.	Natural	-
19N.050.0400.OA	M 5	40	9.2	2.5	PA-6/66	Std.	Natural	-
19N.060.0080.OA	M 6	8	11.0	3.0	PA-6/66	Std.	Natural	-
19N.060.0100.OA	M 6	10	11.0	3.0	PA-6/66	Std.	Natural	-
19N.060.0120.OA	M 6	12	11.0	3.0	PA-6/66	Std.	Natural	-
19N.060.0160.OA	M 6	16	11.0	3.0	PA-6/66	Std.	Natural	-
19N.060.0200.OA	M 6	20	11.0	3.0	PA-6/66	Std.	Natural	-
19N.060.0250.OA	M 6	25	11.0	3.0	PA-6/66	Std.	Natural	-
19N.060.0450.OA	M 6	45	11.0	3.0	PA-6/66	Std.	Natural	-
19N.080.0100.OA	M 8	10	14.5	4.0	PA-6/66	Std.	Natural	-
19N.080.0100.OAD	M 8	10	14.5	4.0	PA-6/66	Std.	Natural	DIN 965
19N.080.0120.OAD	M 8	12	14.5	4.0	PA-6/66	Std.	Natural	DIN 965
19N.080.0150.OAD	M 8	15	14.5	4.0	PA-6/66	Std.	Natural	DIN 965
19N.080.0160.OA	M 8	16	14.5	4.0	PA-6/66	Std.	Natural	-
19N.080.0170.OAD	M 8	17	14.5	4.0	PA-6/66	Std.	Natural	DIN 965
19N.080.0200.OA	M 8	20	14.5	4.0	PA-6/66	Std.	Natural	-
19N.080.0200.OAD	M 8	20	14.5	4.0	PA-6/66	Std.	Natural	DIN 965
19N.080.0250.OA	M 8	25	14.5	4.0	PA-6/66	Std.	Natural	-
19N.080.0250.OAD	M 8	25	14.5	4.0	PA-6/66	Std.	Natural	DIN 965
19N.080.0300.OA	M 8	30	14.5	4.0	PA-6/66	Std.	Natural	-
19N.080.0300.OAD	M 8	30	14.5	4.0	PA-6/66	Std.	Natural	DIN 965
19N.080.0350.OAD	M 8	35	14.5	4.0	PA-6/66	Std.	Natural	DIN 965
19N.080.0400.OAD	M 8	40	14.5	4.0	PA-6/66	Std.	Natural	DIN 965
19N.080.0450.OAD	M 8	45	14.5	4.0	PA-6/66	Std.	Natural	DIN 965
19N.080.0500.OA	M 8	50	14.5	4.0	PA-6/66	Std.	Natural	-
19N.080.0500.OAD	M 8	50	14.5	4.0	PA-6/66	Std.	Natural	DIN 965
19N.080.0550.OAD	M 8	55	14.5	4.0	PA-6/66	Std.	Natural	DIN 965
19N.080.0650.OAD	M 8	65	14.5	4.0	PA-6/66	Std.	Natural	DIN 965
19N.080.0750.OAD	M 8	75	14.5	4.0	PA-6/66	Std.	Natural	DIN 965
19N.080.0850.OAD	M 8	85	14.5	4.0	PA-6/66	Std.	Natural	DIN 965
19N.100.0100.OAD	M10	10	18.0	5.0	PA-6/66	Std.	Natural	DIN 965
19N.100.0120.OAD	M10	12	18.0	5.0	PA-6/66	Std.	Natural	DIN 965
19N.100.0150.OAD	M10	15	18.0	5.0	PA-6/66	Std.	Natural	DIN 965
19N.100.0170.OAD	M10	17	18.0	5.0	PA-6/66	Std.	Natural	DIN 965
19N.100.0200.OAD	M10	20	18.0	5.0	PA-6/66	Std.	Natural	DIN 965
19N.100.0250.OAD	M10	25	18.0	5.0	PA-6/66	Std.	Natural	DIN 965
19N.100.0300.OAD	M10	30	18.0	5.0	PA-6/66	Std.	Natural	DIN 965
19N.100.0350.OAD	M10	35	18.0	5.0	PA-6/66	Std.	Natural	DIN 965
19N.100.0400.OAD	M10	40	18.0	5.0	PA-6/66	Std.	Natural	DIN 965
19N.100.0450.OAD	M10	45	18.0	5.0	PA-6/66	Std.	Natural	DIN 965
19N.100.0500.OAD	M10	50	18.0	5.0	PA-6/66	Std.	Natural	DIN 965
19N.100.0550.OAD	M10	55	18.0	5.0	PA-6/66	Std.	Natural	DIN 965
19N.100.0650.OAD	M10	65	18.0	5.0	PA-6/66	Std.	Natural	DIN 965
19N.100.0750.OAD	M10	75	18.0	5.0	PA-6/66	Std.	Natural	DIN 965
19N.100.0850.OAD	M10	85	18.0	5.0	PA-6/66	Std.	Natural	DIN 965