

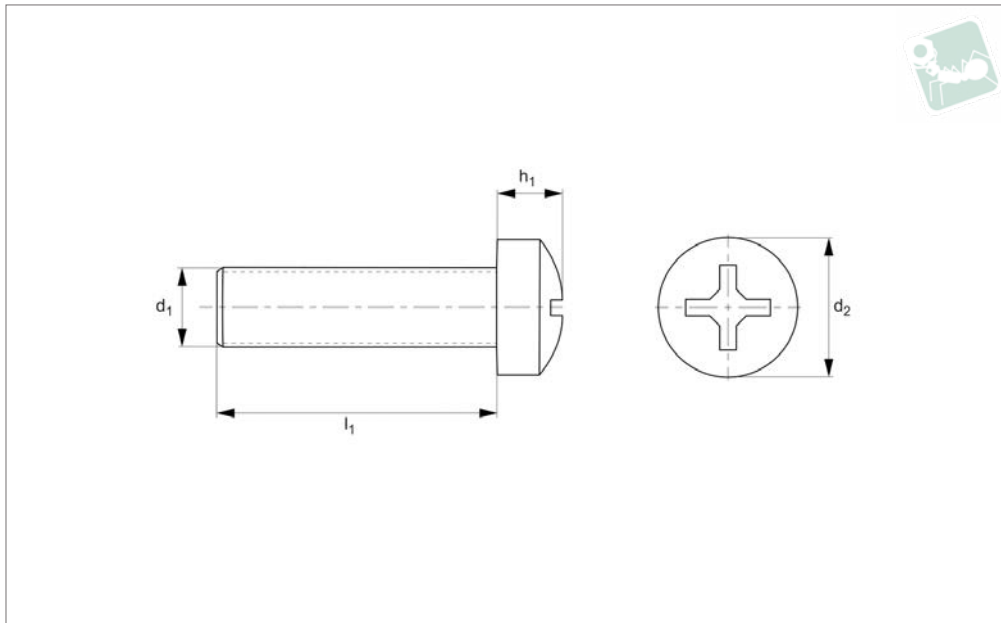

Nylon Phillips Pan Screw

DIN 7985

Nylon



N0025.25N

NYLON

Material

Nylon 66 (PA 6/66), standard. Natural, white or black.

Technical Notes

DIN norms were created for metal parts, the dimensions of our plastic DIN equivalents are close to the norm but do not

follow the strict tolerances typically relevant to metal parts.

Many Nylon parts are available in dyed black, this subject to a minimum value and process charge, please contact us for further details.

Dyed black colour is not long term UV

stable. Nylon parts offer good electrical insulation, is resistant to corrosion and most dilute acids.

Nylon protects work surfaces and absorbs shocks and vibrations.

Order No.	d ₁	l ₁	d ₂	h ₁	Finish
25N.020.0040.0A	M 2	4	4.0	1.6	Natural, white
25N.020.0050.0A	M 2	5	4.0	1.6	Natural, white
25N.020.0060.0A	M 2	6	4.0	1.6	Natural, white
25N.020.0080.0A	M 2	8	4.0	1.6	Natural, white
25N.020.0100.0A	M 2	10	4.0	1.6	Natural, white
25N.020.0120.0A	M 2	12	4.0	1.6	Natural, white
25N.020.0160.0A	M 2	16	4.0	1.6	Natural, white
25N.020.0200.0A	M 2	20	4.0	1.6	Natural, white
25N.020.0250.0A	M 2	25	4.0	1.6	Natural, white
25N.025.0040.0A	M2,5	4	5.0	2.1	Natural, white
25N.025.0050.0A	M2,5	5	5.0	2.1	Natural, white
25N.025.0060.0A	M2,5	6	5.0	2.1	Natural, white
25N.025.0080.0A	M2,5	8	5.0	2.1	Natural, white
25N.025.0100.0A	M2,5	10	5.0	2.1	Natural, white
25N.025.0120.0A	M2,5	12	5.0	2.1	Natural, white
25N.025.0160.0A	M2,5	16	5.0	2.1	Natural, white
25N.025.0200.0A	M2,5	20	5.0	2.1	Natural, white
25N.025.0250.0A	M2,5	25	5.0	2.1	Natural, white
25N.030.0040.0A	M 3	4	5.6	2.4	Natural, white
25N.030.0050.0A	M 3	5	5.6	2.4	Natural, white
25N.030.0060.0A	M 3	6	5.6	2.4	Natural, white
25N.030.0080.0A	M 3	8	5.6	2.4	Natural, white
25N.030.0100.0A	M 3	10	5.6	2.4	Natural, white
25N.030.0120.0A	M 3	12	5.6	2.4	Natural, white
25N.030.0120.0BD	M 3	12	6.0	2.4	Black
25N.030.0160.0A	M 3	16	5.6	2.4	Natural, white
25N.030.0160.0BD	M 3	16	6.0	2.4	Black
25N.030.0200.0A	M 3	20	5.6	2.4	Natural, white
25N.030.0250.0A	M 3	25	5.6	2.4	Natural, white
25N.030.0250.0BD	M 3	25	6.0	2.4	Black
25N.030.0300.0A	M 3	30	5.6	2.4	Natural, white



Order No.	d ₁	l ₁	d ₂	h ₁	Finish
25N.030.0350.0A	M 3	35	5.6	2.4	Natural, white
25N.030.0420.0A	M 3	42	5.6	2.4	Natural, white
25N.035.0050.0A	M3,5	5	7.0	2.6	Natural, white
25N.035.0080.0A	M3,5	8	7.0	2.6	Natural, white
25N.035.0120.0A	M3,5	12	7.0	2.6	Natural, white
25N.035.0160.0A	M3,5	16	7.0	2.6	Natural, white
25N.035.0200.0A	M3,5	20	7.0	2.6	Natural, white
25N.035.0250.0A	M3,5	25	7.0	2.6	Natural, white
25N.035.0420.0A	M3,5	42	7.0	2.6	Natural, white
25N.040.0030.0A	M 4	3	8.0	3.1	Natural, white
25N.040.0060.0A	M 4	6	8.0	3.1	Natural, white
25N.040.0060.0BD	M 4	6	6.0	3.1	Black
25N.040.0080.0A	M 4	8	8.0	3.1	Natural, white
25N.040.0100.0A	M 4	10	8.0	3.1	Natural, white
25N.040.0100.0BD	M 4	10	6.0	3.1	Black
25N.040.0120.0A	M 4	12	8.0	3.1	Natural, white
25N.040.0120.0BD	M 4	12	6.0	3.1	Black
25N.040.0160.0A	M 4	16	8.0	3.1	Natural, white
25N.040.0160.0BD	M 4	16	6.0	3.1	Black
25N.040.0200.0A	M 4	20	8.0	3.1	Natural, white
25N.040.0200.0BD	M 4	20	6.0	3.1	Black
25N.040.0250.0A	M 4	25	8.0	3.1	Natural, white
25N.040.0250.0BD	M 4	25	6.0	3.1	Black
25N.040.0300.0A	M 4	30	8.0	3.1	Natural, white
25N.040.0350.0A	M 4	35	8.0	3.1	Natural, white
25N.040.0400.0A	M 4	40	8.0	3.1	Natural, white
25N.050.0060.0A	M 5	6	9.5	3.7	Natural, white
25N.050.0080.0A	M 5	8	9.5	3.7	Natural, white
25N.050.0100.0A	M 5	10	9.5	3.7	Natural, white
25N.050.0100.0BD	M 5	10	6.0	3.8	Black
25N.050.0120.0A	M 5	12	9.5	3.7	Natural, white
25N.050.0120.0BD	M 5	12	6.0	3.8	Black
25N.050.0160.0A	M 5	16	9.5	3.7	Natural, white
25N.050.0160.0BD	M 5	16	6.0	3.8	Black
25N.050.0200.0A	M 5	20	9.5	3.7	Natural, white
25N.050.0200.0BD	M 5	20	6.0	3.8	Black
25N.050.0250.0A	M 5	25	9.5	3.7	Natural, white
25N.050.0300.0A	M 5	30	9.5	3.7	Natural, white
25N.050.0350.0A	M 5	35	9.5	3.7	Natural, white
25N.050.0400.0A	M 5	40	9.5	3.7	Natural, white
25N.060.0050.0A	M 6	5	12.0	4.6	Natural, white
25N.060.0080.0A	M 6	8	12.0	4.6	Natural, white
25N.060.0080.0BD	M 6	8	6.0	4.6	Black
25N.060.0100.0A	M 6	10	12.0	4.6	Natural, white
25N.060.0100.0BD	M 6	10	6.0	4.6	Black
25N.060.0120.0A	M 6	12	12.0	4.6	Natural, white
25N.060.0120.0BD	M 6	12	6.0	4.6	Black
25N.060.0160.0A	M 6	16	12.0	4.6	Natural, white
25N.060.0160.0BD	M 6	16	6.0	4.6	Black
25N.060.0200.0A	M 6	20	12.0	4.6	Natural, white
25N.060.0200.0BD	M 6	20	6.0	4.6	Black
25N.060.0250.0A	M 6	25	12.0	4.6	Natural, white
25N.060.0250.0BD	M 6	25	6.0	4.6	Black
25N.060.0300.0A	M 6	30	12.0	4.6	Natural, white
25N.060.0350.0A	M 6	35	12.0	4.6	Natural, white
25N.060.0400.0A	M 6	40	12.0	4.6	Natural, white
25N.060.0450.0A	M 6	45	12.0	4.6	Natural, white
25N.060.0500.0A	M 6	50	12.0	4.6	Natural, white
25N.060.0600.0A	M 6	60	12.0	4.6	Natural, white
25N.060.0700.0A	M 6	70	12.0	4.6	Natural, white
25N.060.0750.0A	M 6	75	12.0	4.6	Natural, white
25N.080.0100.0A	M 8	10	16.0	6.0	Natural, white
25N.080.0160.0A	M 8	16	16.0	6.0	Natural, white
25N.080.0200.0A	M 8	20	16.0	6.0	Natural, white
25N.080.0250.0A	M 8	25	16.0	6.0	Natural, white
25N.080.0250.0BD	M 8	25	6.0	6.0	Black
25N.080.0300.0A	M 8	30	16.0	6.0	Natural, white
25N.080.0300.0BD	M 8	30	6.0	6.0	Black
25N.080.0350.0A	M 8	35	16.0	6.0	Natural, white



Nylon Phillips Pan Screw

DIN 7985

Nylon

Order No.	d ₁	l ₁	d ₂	h ₁	Finish
25N.080.0500.0A	M 8	50	16.0	6.0	Natural, white
25N.080.0700.0A	M 8	70	16.0	6.0	Natural, white
25N.100.0130.0A	M10	13	20.0	7.5	Natural, white
25N.100.0160.0A	M10	16	20.0	7.5	Natural, white
25N.100.0160.0B	M10	16	20.0	7.5	Black
25N.100.0200.0A	M10	20	20.0	7.5	Natural, white
25N.100.0250.0A	M10	25	20.0	7.5	Natural, white
25N.100.0300.0A	M10	30	20.0	7.5	Natural, white
25N.100.0350.0A	M10	35	20.0	7.5	Natural, white
25N.100.0500.0A	M10	50	20.0	7.5	Natural, white
25N.100.0600.0A	M10	60	20.0	7.5	Natural, white
25N.030.0060.0BD	M 3	6	6.0	2.4	Black
25N.030.0050.0BD	M 3	5	6.0	2.4	Black
25N.025.0100.0B	M2,5	10	5.0	2.1	Black
25N.030.0040.0B	M 3	4	5.6	2.4	Black

NYLON