

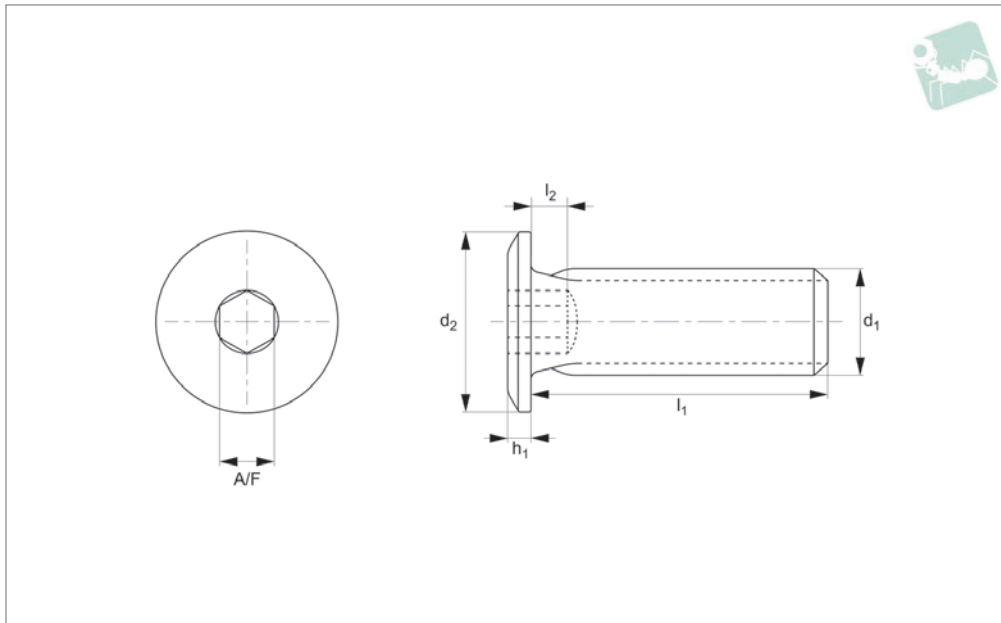

# Ultra Low Head Cap Screws

Natural PEEK

## Other Plastics



**N0508.NP**

OTHER PLASTICS

### Material

Polyether Ether Ketone (PEEK) is a high performance engineering plastic, known for its durability and chemical resistance. It has excellent dimensional stability and a maximum operating temperature of 260°C. Natural PEEK is used in this range which is light brown in colour.

### Technical Notes

PEEK is used in the aerospace and petro-

chemical industries. For food and pharmaceutical industries we can offer these products in a compound that is FDA compliant, as well as highly optically and metal detectable.

Manufactured for industries with a hygienic requirement, these products are made with an X-Ray opaque or metal detectable filler, in blue, for optical detection. For medical

industry applications, we can offer these products in a variant of PEEK which is refined for biocompatibility. Natural PEEK is used in the aerospace and chemical industries.

Order No.	d <sub>1</sub>	l <sub>1</sub> +/- 0.2	d <sub>2</sub>	h <sub>1</sub>	l <sub>2</sub> max.	A/F
N0508.030-008-NP	M 3	8	6	0.8	1.0	1.5
N0508.030-010-NP	M 3	10	6	0.8	1.0	1.5
N0508.030-012-NP	M 3	12	6	0.8	1.0	1.5
N0508.030-015-NP	M 3	15	6	0.8	1.0	1.5
N0508.030-020-NP	M 3	20	6	0.8	1.0	1.5
N0508.030-025-NP	M 3	25	6	0.8	1.0	1.5
N0508.040-008-NP	M 4	8	8	0.9	1.4	2.0
N0508.040-010-NP	M 4	10	8	0.9	1.4	2.0
N0508.040-012-NP	M 4	12	8	0.9	1.4	2.0
N0508.040-015-NP	M 4	15	8	0.9	1.4	2.0
N0508.040-020-NP	M 4	20	8	0.9	1.4	2.0
N0508.040-025-NP	M 4	25	8	0.9	1.4	2.0
N0508.050-008-NP	M 5	8	9	1.0	1.6	2.5
N0508.050-012-NP	M 5	12	9	1.0	1.6	2.5
N0508.050-015-NP	M 5	15	9	1.0	1.6	2.5
N0508.050-020-NP	M 5	20	9	1.0	1.6	2.5
N0508.050-025-NP	M 5	25	9	1.0	1.6	2.5
N0508.050-030-NP	M 5	30	9	1.0	1.6	2.5
N0508.060-010-NP	M 6	10	10	1.2	2.0	3.0
N0508.060-012-NP	M 6	12	10	1.2	2.0	3.0
N0508.060-015-NP	M 6	15	10	1.2	2.0	3.0
N0508.060-020-NP	M 6	20	10	1.2	2.0	3.0
N0508.060-025-NP	M 6	25	10	1.2	2.0	3.0
N0508.060-030-NP	M 6	30	10	1.2	2.0	3.0