

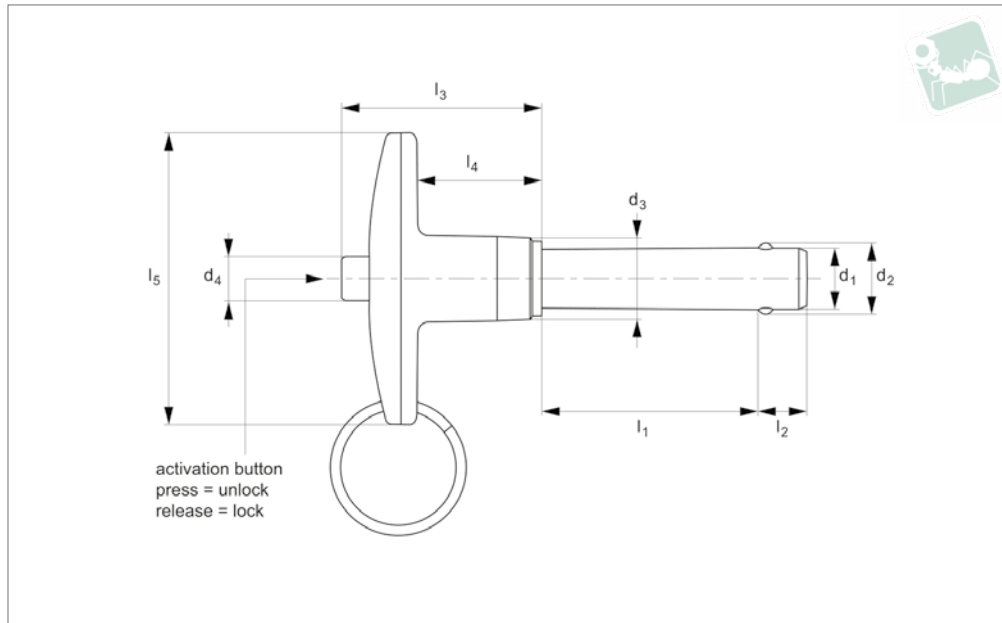

Quick Release Pins - Inch - T-handle steel pin

Quick Release Pins



QR1022

QUICK RELEASE PINS

Material

Pin: alloy steel, 4130 (DIN 1.7218), Cadmium plated. Tensile strength 1,100 N/mm² min. Non-RoHS compliant.
Handle: Alu. 380 die cast (DIN ALSi9Cu3), black anodised (RAL 9003).
Actuator button: Alu. 2024-T4 (DIN AlCuMg2), anodised blue or clear.

Internal spindle, balls and split ring (supplied); from stainless steel.

Technical Notes

Pressing = unlocking.
Releasing = locking.
Temperature range -30°C to +150°C
Supplied with split ring.

Tips

For quick fastening and locking frequently repeated connections.
For lanyards & retaining cables see part nos. L to LA1224. For easy install locating bushes and end caps see part nos. LA1260 to LA1355.

Order No.	d ₁ nom.	l ₁ grip +0.02 - 0.00	Material	d ₁ max.	d ₁ min.	d ₂ ±0.005	d ₃	d ₄	l ₂ +0.000 - -0.030	l ₃	l ₄	l ₅	Loc'n hole min. max.	Pull out strength lb min.	Calc. double shear lb
QR1022.I18-050-C	3/16	0,50	4130 Steel	,1885	,1870	0,220	0,47	0,23	0,260	1,21	0,76	1,81	,1900/,1940	200	4600
QR1022.I18-075-C	3/16	0,75	4130 Steel	,1885	,1870	0,220	0,47	0,23	0,260	1,21	0,76	1,81	,1900/,1940	200	4600
QR1022.I18-100-C	3/16	1,00	4130 Steel	,1885	,1870	0,220	0,47	0,23	0,260	1,21	0,76	1,81	,1900/,1940	200	4600
QR1022.I18-125-C	3/16	1,25	4130 Steel	,1885	,1870	0,220	0,47	0,23	0,260	1,21	0,76	1,81	,1900/,1940	200	4600
QR1022.I18-150-C	3/16	1,50	4130 Steel	,1885	,1870	0,220	0,47	0,23	0,260	1,21	0,76	1,81	,1900/,1940	200	4600
QR1022.I18-175-C	3/16	1,75	4130 Steel	,1885	,1870	0,220	0,47	0,23	0,260	1,21	0,76	1,81	,1900/,1940	200	4600
QR1022.I18-200-C	3/16	2,00	4130 Steel	,1885	,1870	0,220	0,47	0,23	0,260	1,21	0,76	1,81	,1900/,1940	200	4600
QR1022.I18-250-C	3/16	2,50	4130 Steel	,1885	,1870	0,220	0,47	0,23	0,260	1,21	0,76	1,81	,1900/,1940	200	4600
QR1022.I18-300-C	3/16	3,00	4130 Steel	,1885	,1870	0,220	0,47	0,23	0,260	1,21	0,76	1,81	,1900/,1940	200	4600
QR1022.I18-350-C	3/16	3,50	4130 Steel	,1885	,1870	0,220	0,47	0,23	0,260	1,21	0,76	1,81	,1900/,1940	200	4600
QR1022.I18-400-C	3/16	4,00	4130 Steel	,1885	,1870	0,220	0,47	0,23	0,260	1,21	0,76	1,81	,1900/,1940	200	4600
QR1022.I25-050-C	1/4	0,50	4130 Steel	,2485	,2470	0,289	0,47	0,23	0,290	1,21	0,76	1,81	,2500/,2540	230	8200
QR1022.I25-075-C	1/4	0,75	4130 Steel	,2485	,2470	0,289	0,47	0,23	0,290	1,21	0,76	1,81	,2500/,2540	230	8200
QR1022.I25-100-C	1/4	1,00	4130 Steel	,2485	,2470	0,289	0,47	0,23	0,290	1,21	0,76	1,81	,2500/,2540	230	8200
QR1022.I25-125-C	1/4	1,25	4130 Steel	,2485	,2470	0,289	0,47	0,23	0,290	1,21	0,76	1,81	,2500/,2540	230	8200
QR1022.I25-150-C	1/4	1,50	4130 Steel	,2485	,2470	0,289	0,47	0,23	0,290	1,21	0,76	1,81	,2500/,2540	230	8200
QR1022.I25-175-C	1/4	1,75	4130 Steel	,2485	,2470	0,289	0,47	0,23	0,290	1,21	0,76	1,81	,2500/,2540	230	8200
QR1022.I25-200-C	1/4	2,00	4130 Steel	,2485	,2470	0,289	0,47	0,23	0,290	1,21	0,76	1,81	,2500/,2540	230	8200
QR1022.I25-250-C	1/4	2,50	4130 Steel	,2485	,2470	0,289	0,47	0,23	0,290	1,21	0,76	1,81	,2500/,2540	230	8200
QR1022.I25-300-C	1/4	3,00	4130 Steel	,2485	,2470	0,289	0,47	0,23	0,290	1,21	0,76	1,81	,2500/,2540	230	8200
QR1022.I25-350-C	1/4	3,50	4130 Steel	,2485	,2470	0,289	0,47	0,23	0,290	1,21	0,76	1,81	,2500/,2540	230	8200
QR1022.I25-400-C	1/4	4,00	4130 Steel	,2485	,2470	0,289	0,47	0,23	0,290	1,21	0,76	1,81	,2500/,2540	230	8200
QR1022.I31-050-C	5/16	0,50	4130 Steel	,3110	,3095	0,375	0,47	0,23	0,330	1,21	0,76	1,81	,3125/,3165	510	12800
QR1022.I31-075-C	5/16	0,75	4130 Steel	,3110	,3095	0,375	0,47	0,23	0,330	1,21	0,76	1,81	,3125/,3165	510	12800
QR1022.I31-100-C	5/16	1,00	4130 Steel	,3110	,3095	0,375	0,47	0,23	0,330	1,21	0,76	1,81	,3125/,3165	510	12800
QR1022.I31-125-C	5/16	1,25	4130 Steel	,3110	,3095	0,375	0,47	0,23	0,330	1,21	0,76	1,81	,3125/,3165	510	12800
QR1022.I31-150-C	5/16	1,50	4130 Steel	,3110	,3095	0,375	0,47	0,23	0,330	1,21	0,76	1,81	,3125/,3165	510	12800
QR1022.I31-175-C	5/16	1,75	4130 Steel	,3110	,3095	0,375	0,47	0,23	0,330	1,21	0,76	1,81	,3125/,3165	510	12800

Quick Release Pins

Quick Release Pins - Inch - T-handle steel pin



QUICK RELEASE PINS

Order No.	d ₁ nom.	l ₁ grip +0.02 - 0.00	Material	d ₁ max.	d ₁ min.	d ₂ ±0.005	d ₃	d ₄	l ₂ +0.000 - -0.030	l ₃	l ₄	l ₅	Loc'n hole min. max.	Pull out strength lb min.	Calc. double shear lb
QR1022.I31-200-C	5/16	2,00	4130 Steel	,3110	,3095	0,375	0,47	0,23	0,330	1,21	0,76	1,81	,3125/,3165	510	12800
QR1022.I31-250-C	5/16	2,50	4130 Steel	,3110	,3095	0,375	0,47	0,23	0,330	1,21	0,76	1,81	,3125/,3165	510	12800
QR1022.I31-300-C	5/16	3,00	4130 Steel	,3110	,3095	0,375	0,47	0,23	0,330	1,21	0,76	1,81	,3125/,3165	510	12800
QR1022.I31-350-C	5/16	3,50	4130 Steel	,3110	,3095	0,375	0,47	0,23	0,330	1,21	0,76	1,81	,3125/,3165	510	12800
QR1022.I31-400-C	5/16	4,00	4130 Steel	,3110	,3095	0,375	0,47	0,23	0,330	1,21	0,76	1,81	,3125/,3165	510	12800
QR1022.I37-050-C	3/8	0,50	4130 Steel	,3735	,3720	0,440	0,56	0,29	0,365	1,37	0,87	2,00	,3750/,3790	575	18400
QR1022.I37-075-C	3/8	0,75	4130 Steel	,3735	,3720	0,440	0,56	0,29	0,365	1,37	0,87	2,00	,3750/,3790	575	18400
QR1022.I37-100-C	3/8	1,00	4130 Steel	,3735	,3720	0,440	0,56	0,29	0,365	1,37	0,87	2,00	,3750/,3790	575	18400
QR1022.I37-125-C	3/8	1,25	4130 Steel	,3735	,3720	0,440	0,56	0,29	0,365	1,37	0,87	2,00	,3750/,3790	575	18400
QR1022.I37-150-C	3/8	1,50	4130 Steel	,3735	,3720	0,440	0,56	0,29	0,365	1,37	0,87	2,00	,3750/,3790	575	18400
QR1022.I37-175-C	3/8	1,75	4130 Steel	,3735	,3720	0,440	0,56	0,29	0,365	1,37	0,87	2,00	,3750/,3790	575	18400
QR1022.I37-200-C	3/8	2,00	4130 Steel	,3735	,3720	0,440	0,56	0,29	0,365	1,37	0,87	2,00	,3750/,3790	575	18400
QR1022.I37-250-C	3/8	2,50	4130 Steel	,3735	,3720	0,440	0,56	0,29	0,365	1,37	0,87	2,00	,3750/,3790	575	18400
QR1022.I37-300-C	3/8	3,00	4130 Steel	,3735	,3720	0,440	0,56	0,29	0,365	1,37	0,87	2,00	,3750/,3790	575	18400
QR1022.I37-350-C	3/8	3,50	4130 Steel	,3735	,3720	0,440	0,56	0,29	0,365	1,37	0,87	2,00	,3750/,3790	575	18400
QR1022.I37-400-C	3/8	4,00	4130 Steel	,3735	,3720	0,440	0,56	0,29	0,365	1,37	0,87	2,00	,3750/,3790	575	18400
QR1022.I50-100-C	1/2	1,00	4130 Steel	,4985	,4970	0,594	0,72	0,42	0,460	1,60	1,00	2,25	,5000/,5050	1160	32800
QR1022.I50-125-C	1/2	1,25	4130 Steel	,4985	,4970	0,594	0,72	0,42	0,460	1,60	1,00	2,25	,5000/,5050	1160	32800
QR1022.I50-150-C	1/2	1,50	4130 Steel	,4985	,4970	0,594	0,72	0,42	0,460	1,60	1,00	2,25	,5000/,5050	1160	32800
QR1022.I50-175-C	1/2	1,75	4130 Steel	,4985	,4970	0,594	0,72	0,42	0,460	1,60	1,00	2,25	,5000/,5050	1160	32800
QR1022.I50-200-C	1/2	2,00	4130 Steel	,4985	,4970	0,594	0,72	0,42	0,460	1,60	1,00	2,25	,5000/,5050	1160	32800
QR1022.I50-250-C	1/2	2,50	4130 Steel	,4985	,4970	0,594	0,72	0,42	0,460	1,60	1,00	2,25	,5000/,5050	1160	32800
QR1022.I50-300-C	1/2	3,00	4130 Steel	,4985	,4970	0,594	0,72	0,42	0,460	1,60	1,00	2,25	,5000/,5050	1160	32800
QR1022.I50-350-C	1/2	3,50	4130 Steel	,4985	,4970	0,594	0,72	0,42	0,460	1,60	1,00	2,25	,5000/,5050	1160	32800
QR1022.I50-400-C	1/2	4,00	4130 Steel	,4985	,4970	0,594	0,72	0,42	0,460	1,60	1,00	2,25	,5000/,5050	1160	32800
QR1022.I50-450-C	1/2	4,50	4130 Steel	,4985	,4970	0,594	0,72	0,42	0,460	1,60	1,00	2,25	,5000/,5050	1160	32800
QR1022.I50-500-C	1/2	5,00	4130 Steel	,4985	,4970	0,594	0,72	0,42	0,460	1,60	1,00	2,25	,5000/,5050	1160	32800
QR1022.I50-550-C	1/2	5,50	4130 Steel	,4985	,4970	0,594	0,72	0,42	0,460	1,60	1,00	2,25	,5000/,5050	1160	32800
QR1022.I50-600-C	1/2	6,00	4130 Steel	,4985	,4970	0,594	0,72	0,42	0,460	1,60	1,00	2,25	,5000/,5050	1160	32800
QR1022.I62-150-C	5/8	1,50	4130 Steel	,6235	,6220	0,750	0,94	0,54	0,580	1,77	1,11	3,07	,6250/,6300	2070	51200
QR1022.I62-175-C	5/8	1,75	4130 Steel	,6235	,6220	0,750	0,94	0,54	0,580	1,77	1,11	3,07	,6250/,6300	2070	51200
QR1022.I62-200-C	5/8	2,00	4130 Steel	,6235	,6220	0,750	0,94	0,54	0,580	1,77	1,11	3,07	,6250/,6300	2070	51200
QR1022.I62-250-C	5/8	2,50	4130 Steel	,6235	,6220	0,750	0,94	0,54	0,580	1,77	1,11	3,07	,6250/,6300	2070	51200
QR1022.I62-300-C	5/8	3,00	4130 Steel	,6235	,6220	0,750	0,94	0,54	0,580	1,77	1,11	3,07	,6250/,6300	2070	51200
QR1022.I62-350-C	5/8	3,50	4130 Steel	,6235	,6220	0,750	0,94	0,54	0,580	1,77	1,11	3,07	,6250/,6300	2070	51200
QR1022.I62-400-C	5/8	4,00	4130 Steel	,6235	,6220	0,750	0,94	0,54	0,580	1,77	1,11	3,07	,6250/,6300	2070	51200
QR1022.I62-450-C	5/8	4,50	4130 Steel	,6235	,6220	0,750	0,94	0,54	0,580	1,77	1,11	3,07	,6250/,6300	2070	51200
QR1022.I62-500-C	5/8	5,00	4130 Steel	,6235	,6220	0,750	0,94	0,54	0,580	1,77	1,11	3,07	,6250/,6300	2070	51200
QR1022.I62-550-C	5/8	5,50	4130 Steel	,6235	,6220	0,750	0,94	0,54	0,580	1,77	1,11	3,07	,6250/,6300	2070	51200
QR1022.I62-600-C	5/8	6,00	4130 Steel	,6235	,6220	0,750	0,94	0,54	0,580	1,77	1,11	3,07	,6250/,6300	2070	51200