

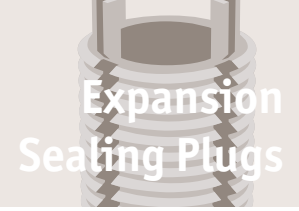

Expansion Sealing Plugs - Inch

Inch - short



Expansion Sealing Plugs

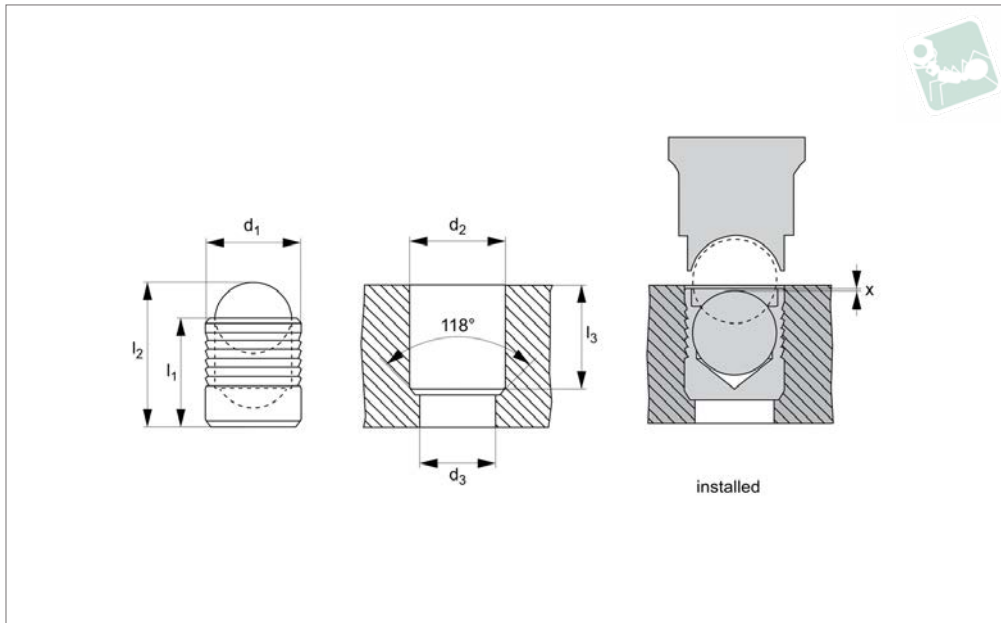

SE0505

EXPANSION SEALING PLUGS

Material

Plug body: case hardened steel (zinc-plated), stainless steel (A2, AISI 303 & A4 AISI 316) or aluminium (2024-T4).

Ball: heat-treated bearing steel or stainless steel (A2, AISI 303 & A4 AISI 316).

Technical Notes

These high pressure sealing plugs are used to blank off externally drilled holes for air

and gas.

No need for tapping, reaming, machining of O-ring grooves or the use of tapes or sealants.

Ensure the ball is fully seated before applying pressure.

Dimensions in inches.

Tips

Working pressure up to 450 bar (dependent

on body material and material into which installed).

Please consult technical pages for installation instructions and performance data.

Important Notes

Please refer to technical pages for product installation details.

Order No.	d ₁	l ₁	l ₂	d ₂ +0.004 -0.000	d ₃ max.	l ₃ min.	x +0.01 -0.010	Body	Ball
SE0505.01-093-C	0.0937	0.098	0.12	0.0937	0.070	0.081	0.010	Steel ZP	Steel
SE0505.01-125-C	0.1250	0.125	0.16	0.1250	0.100	0.113	0.010	Steel ZP	Steel
SE0505.01-156-C	0.1562	0.125	0.17	0.1562	0.130	0.113	0.010	Steel ZP	Steel
SE0505.01-187-C	0.1875	0.187	0.24	0.1875	0.160	0.170	0.010	Steel ZP	Steel
SE0505.01-218-C	0.2187	0.187	0.25	0.2187	0.190	0.170	0.010	Steel ZP	Steel
SE0505.01-250-C	0.2500	0.225	0.30	0.2500	0.220	0.196	0.010	Steel ZP	Steel
SE0505.01-281-C	0.2812	0.225	0.35	0.2812	0.250	0.233	0.010	Steel ZP	Steel
SE0505.01-312-C	0.3125	0.280	0.39	0.3125	0.281	0.255	0.010	Steel ZP	Steel
SE0505.01-343-C	0.3437	0.307	0.43	0.3437	0.312	0.275	0.010	Steel ZP	Steel
SE0505.01-406-C	0.4062	0.365	0.52	0.4062	0.375	0.308	0.010	Steel ZP	Steel
SE0505.02-093-S	0.0937	0.098	0.12	0.0937	0.070	0.081	0.010	A2 s/s	Steel
SE0505.02-125-S	0.1250	0.125	0.16	0.1250	0.100	0.113	0.010	A2 s/s	Steel
SE0505.02-156-S	0.1562	0.125	0.17	0.1562	0.130	0.113	0.010	A2 s/s	Steel
SE0505.02-187-S	0.1875	0.187	0.24	0.1875	0.160	0.170	0.010	A2 s/s	Steel
SE0505.02-218-S	0.2187	0.187	0.25	0.2187	0.190	0.170	0.010	A2 s/s	Steel
SE0505.02-250-S	0.2500	0.225	0.30	0.2500	0.220	0.196	0.010	A2 s/s	Steel
SE0505.02-281-S	0.2812	0.225	0.35	0.2812	0.250	0.233	0.010	A2 s/s	Steel
SE0505.02-312-S	0.3125	0.280	0.39	0.3125	0.281	0.255	0.010	A2 s/s	Steel
SE0505.02-343-S	0.3437	0.307	0.43	0.3437	0.312	0.275	0.010	A2 s/s	Steel
SE0505.02-406-S	0.4062	0.365	0.52	0.4062	0.375	0.308	0.010	A2 s/s	Steel
SE0505.03-093-S	0.0937	0.098	0.12	0.0937	0.070	0.081	0.010	A2 s/s	A2 s/s
SE0505.03-125-S	0.1250	0.125	0.16	0.1250	0.100	0.113	0.010	A2 s/s	A2 s/s
SE0505.03-156-S	0.1562	0.125	0.17	0.1562	0.130	0.113	0.010	A2 s/s	A2 s/s
SE0505.03-187-S	0.1875	0.187	0.24	0.1875	0.160	0.170	0.010	A2 s/s	A2 s/s
SE0505.03-218-S	0.2187	0.187	0.25	0.2187	0.190	0.170	0.010	A2 s/s	A2 s/s
SE0505.03-250-S	0.2500	0.225	0.30	0.2500	0.220	0.196	0.010	A2 s/s	A2 s/s
SE0505.03-281-S	0.2812	0.225	0.35	0.2812	0.250	0.233	0.010	A2 s/s	A2 s/s
SE0505.03-312-S	0.3125	0.280	0.39	0.3125	0.281	0.255	0.010	A2 s/s	A2 s/s



Order No.	d ₁	l ₁	l ₂	d ₂ +0.004 -0.000	d ₃ max.	l ₃ min.	x +0.0 -0.010	Body	Ball
SE0505.03-343-S	0.3437	0.307	0.43	0.3437	0.312	0.275	0.010	A2 s/s	A2 s/s
SE0505.03-406-S	0.4062	0.365	0.52	0.4062	0.375	0.308	0.010	A2 s/s	A2 s/s
SE0505.04-125-T	0.1250	0.125	0.16	0.1250	0.100	0.113	0.010	A4 s/s	A4 s/s
SE0505.04-156-T	0.1562	0.125	0.17	0.1562	0.130	0.113	0.010	A4 s/s	A4 s/s
SE0505.04-187-T	0.1875	0.187	0.24	0.1875	0.160	0.170	0.010	A4 s/s	A4 s/s
SE0505.04-218-T	0.2187	0.187	0.25	0.2187	0.190	0.170	0.010	A4 s/s	A4 s/s
SE0505.04-250-T	0.2500	0.225	0.30	0.2500	0.220	0.196	0.010	A4 s/s	A4 s/s
SE0505.04-281-T	0.2812	0.225	0.35	0.2812	0.250	0.233	0.010	A4 s/s	A4 s/s
SE0505.04-312-T	0.3125	0.280	0.39	0.3125	0.281	0.255	0.010	A4 s/s	A4 s/s
SE0505.04-343-T	0.3437	0.307	0.43	0.3437	0.312	0.275	0.010	A4 s/s	A4 s/s
SE0505.04-406-T	0.4062	0.365	0.52	0.4062	0.375	0.308	0.010	A4 s/s	A4 s/s
SE0505.05-125-A	0.1250	0.125	0.16	0.1250	0.100	0.113	0.010	Aluminium	A2 s/s
SE0505.05-156-A	0.1562	0.125	0.17	0.1562	0.130	0.113	0.010	Aluminium	A2 s/s
SE0505.05-187-A	0.1875	0.187	0.24	0.1875	0.160	0.170	0.010	Aluminium	A2 s/s
SE0505.05-218-A	0.2187	0.187	0.25	0.2187	0.190	0.170	0.010	Aluminium	A2 s/s
SE0505.05-250-A	0.2500	0.225	0.30	0.2500	0.220	0.196	0.010	Aluminium	A2 s/s
SE0505.05-281-A	0.2812	0.225	0.35	0.2812	0.250	0.233	0.010	Aluminium	A2 s/s
SE0505.05-312-A	0.3125	0.280	0.39	0.3125	0.281	0.255	0.010	Aluminium	A2 s/s
SE0505.05-343-A	0.3437	0.307	0.43	0.3437	0.312	0.275	0.010	Aluminium	A2 s/s
SE0505.05-406-A	0.4062	0.365	0.52	0.4062	0.375	0.308	0.010	Aluminium	A2 s/s

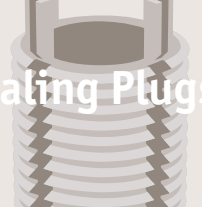

Hydraulic and pneumatic components and systems are often cross-drilled to provide the correct channels for air and gas. Some of these channels have to be drilled from the outside and later need to be closed off (plugged).

The expansion sealing plugs are inserted into a drilled hole and the expander ball is driven into the plug sleeve. The independent grooved sealing rings on the plug ball are driven into the housing material to permanently plug and seal the hole. The ball is retained in place.

No need for tapping or reaming, no machining of O ring grooves or the use of tapes or sealants. To seal a hole, follow this procedure:

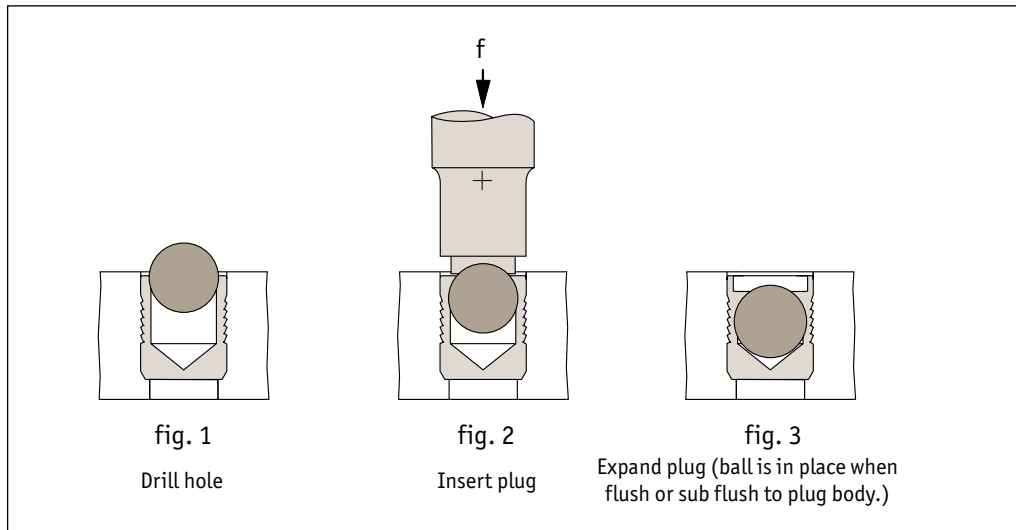

Applications

Some of the typical applications for our sealing screws include:

- Pneumatics
- Hydraulics
- Fluid Power
- Automation
- Industrial
- Aerospace
- Valves
- Regulators
- Cylinders



“Standard” Expansion sealing plugs - push the ball which expands the sleeve and seals the channel.



“Pull” Expansion sealing plugs. Pulling on the mandrel expands the sleeve, sealing the channel. At a predetermined force the mandrel breaks off.

Sealing Plugs from Automation Components

EXPANSION SEALING PLUGS



Hole Preparation

Refer to the data sheet for the correct hole size to drill for the counterbored and drilled hole size and tolerance. Hole concentricity must be held within 0,05mm.

Bore roughness must be between Rz (RMS) 10-30µ (especially for hard materials).

Avoid spiral or longitudinal grooves as these may affect plug performance. Ensure the holes are clean and dirt free.

Installation

Insert the plug into the counterbored hole with the ball facing outwards, seated against the counterbore shoulder.

Press the ball into the sleeve so that the top of the ball is slightly below the top of the sleeve (note approximate values for x and s in table below):

d_1	3	4	5	6	7	8	9	10	12	14	16	18	20	22
Stroke - s	1.2	1.5	2.0	2.5	3.0	3.5	4.0	4.5	5.5	6.35	7.0	8.0	9.0	10.0
Top of ball relative to top of sleeve - x ±0.2	0.4	0.2	0.4	0.4	0.4	0.3	0.4	0.4	0.4	0.4	0.6	0.6	0.8	0.8

Use the correct installation tool for each plug size. The plugs can be installed using a hammer and the installation tool. An air hammer with the correct air hammer installation tool can also be used.

Minimum wall thickness and distance from an edge

The radial expansion of the plug causes the housing material around the plug to deform plastically. Therefore a proper minimum wall thickness or distance from an edge is necessary to optimise the strength of the mechanical connection. The operating hydraulic pressure, thermal cycling, plug type and characteristics of the base metal also need to be considered – please consult our technical department.

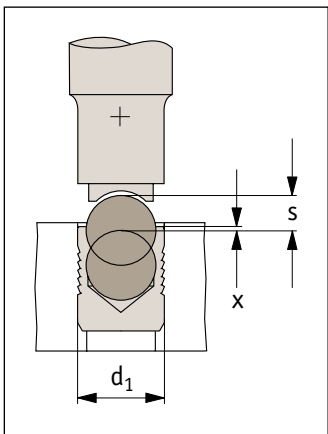

$$d_1 \geq 4\text{mm}$$

$$W_{\min} = f_{\min} \times d_1$$

$$d_1 < 4\text{mm}$$

$$W_{\min} = (f_{\min} \times d_1) + 0.5\text{mm}$$

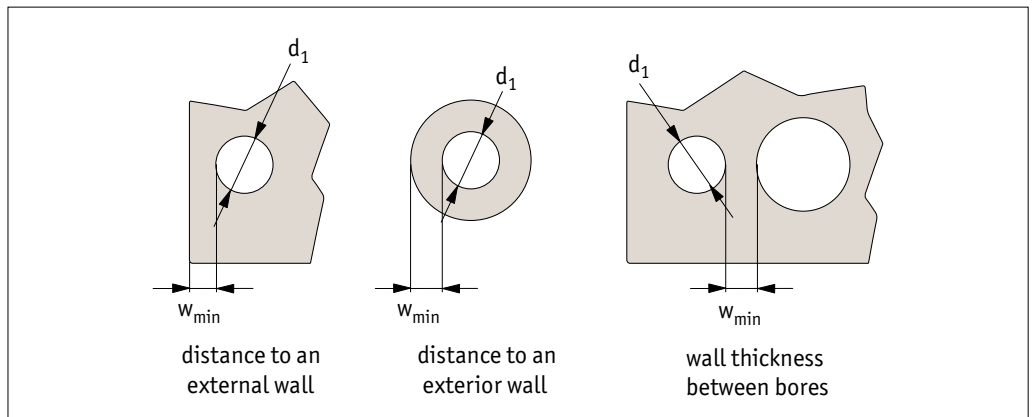

The guidelines for minimum wall thickness or distance from and edge (W_{\min}) are shown below – these minimum values produce only a very slight deformation on the exterior profile (less than 20 microns).

Sealing Plug type	Base Metal						
	Steel (SAE 1144)	Steel (SAE 10L15)	Cast Iron (ASTM A48)	Ductile Iron (ASTM A356)	Aluminium (2024-T4)	Aluminium (6061-T6)	Cast Aluminium (356-T6)
	Factor f_{\min}						
Steel body	0.5	0.6	1.0	0.6	0.6	1.0	1.0
Stainless Body	0.6	0.8	1.0	0.8	0.8	1.0	1.0
Pull PLUGs	0.5	0.6	1.0	0.6	0.6	1.0	1.0

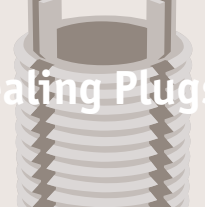

Installation Forces Guidelines

The values offered are to be used as a guideline. The base metal chosen for your specific application, the surface treatment, hole size and surface finish all affect the seal performance. Please contact our Technical Department for more information.

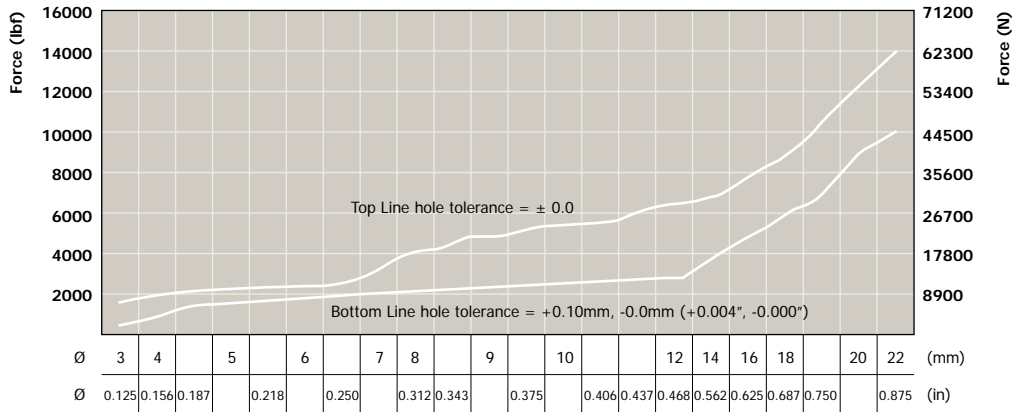

Installation Forces:

Pressure Performance Guidelines

	Steel (Case-hardened) Plug Body	
	Ø 3-10	Ø 12-32
Steel (SAE 1144)	350 bar working pressure 1,100 bar proof pressure	380 bar working pressure 900 bar proof pressure
Steel (SAE 10L15)		
Cast Iron (ASTM A48)		
Ductile Iron (ASTM A356)		
Aluminium (2024-T4)	310 bar working pressure 1,000 bar proof pressure	240 bar working pressure 800 bar proof pressure
Aluminium (6061-T6)		
Cast Aluminium (356-T6)		

	Stainless Steel (300 Series) Plug Body	
	Ø 3-10	Ø 12-32
Steel (SAE 1144)	450 bar working pressure 1,300 bar proof pressure	450 bar working pressure 1,100 bar proof pressure
Steel (SAE 10L15)		
Cast Iron (ASTM A48)		
Ductile Iron (ASTM A356)		
Aluminium (2024-T4)	380 bar working pressure 1,200 bar proof pressure	280 bar working pressure 900 bar proof pressure
Aluminium (6061-T6)		
Cast Aluminium (356-T6)		

	Aluminium (2024-T4) Plug Body	
	Ø 3-10	Ø 12-32
Steel (SAE 1144)	450 bar working pressure 1,300 bar proof pressure	350 bar working pressure 1,100 bar proof pressure
Steel (SAE 10L15)		
Cast Iron (ASTM A48)		
Ductile Iron (ASTM A356)		
Aluminium (2024-T4)	380 bar working pressure 1,200 bar proof pressure	280 bar working pressure 900 bar proof pressure
Aluminium (6061-T6)		
Cast Aluminium (356-T6)		