

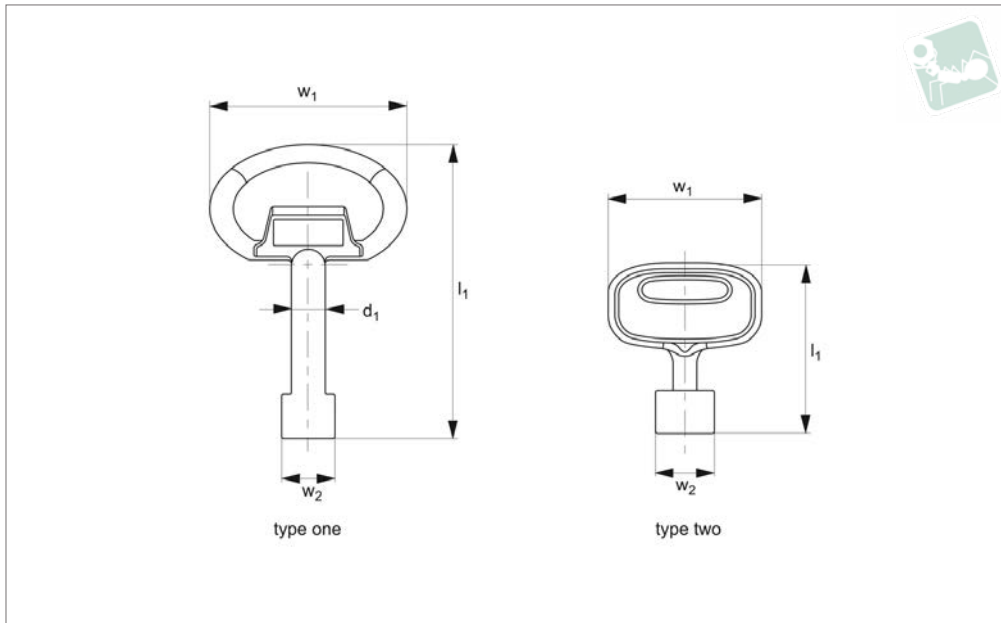

Keys - Flexi-System

for cam latches and locks - zinc

Latches



CC0010

LATCHES

Material

Die cast zinc.

Technical Notes

Keys for our range of cam latches. For slot

type cam latches no special key required - simply use flat head screwdriver.

Note: For part .AW0006 (Square 6) use key CC0010.AW0206 only.

Important Notes

Sold subject to pack quantity.

Order No.	Insert driver	Type	d ₁	l ₁	w ₁	w ₂
CC0010.M0006	Square 6	Type One	9	74.5	49	13.8
CC0010.M0010	Square 7	Type One	9	74.5	49	13.8
CC0010.M0020	Square 8	Type One	9	74.5	49	13.8
CC0010.M0040	Triangle 7	Type One	9	74.5	49	13.8
CC0010.M0050	Triangle 8	Type One	9	74.5	49	13.8
CC0010.M0055	Triangle 9	Type One	9	74.5	49	13.8
CC0010.M0060	3mm Double Bit	Type One	9	70.0	49	13.2
CC0010.M0090	8mm Hex Pin	Type One	9	74.5	49	13.8
CC0010.M0100	10mm Hex Socket	Type One	9	74.5	49	13.8
CC0010.M0306	Square 6	Type two	9	32.0	30	11.0

Available insert drivers:

Square 6	Square 7	Square 8	Triangle 7	Triangle 8	Triangle 9	3-5mm Double Bit	Hexagon 8 with pin	10mm Hex. Socket	2 x 4mm Slotted
6	7	8	6.5	8	9	∅ 3-5	8	10	

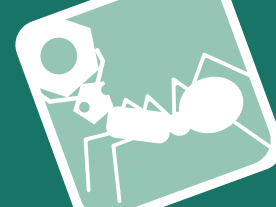

CC0013

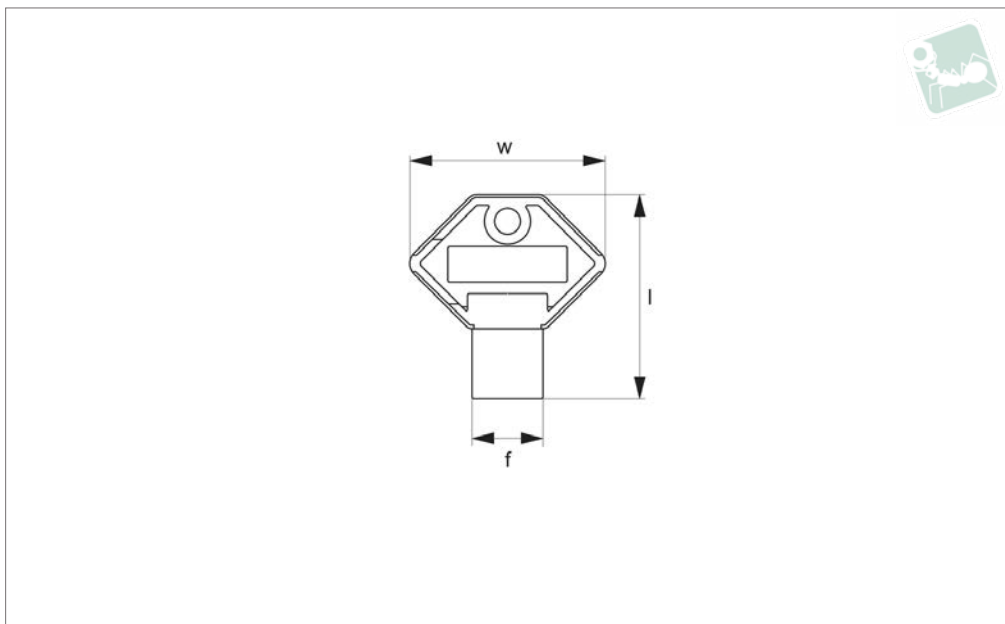

Material

Body: plastic.

type cam latches no special key required - simply use flat head screwdriver.

Technical Notes

Keys for our range of cam latches. For slot

Important Notes

Sold subject to pack quantity.

Order No.	Insert driver	f	l	w
CC0013.M0040	7mm Triangle	40	41.5	40
CC0013.M0006	6mm Square	40	41.5	40
CC0013.M0010	7mm Square	40	41.5	40
CC0013.M0020	8mm Square	40	41.5	40



Single Point Cams - Flexi-System

for cam latches and locks - steel - 8 x 8 Sq.

Latches

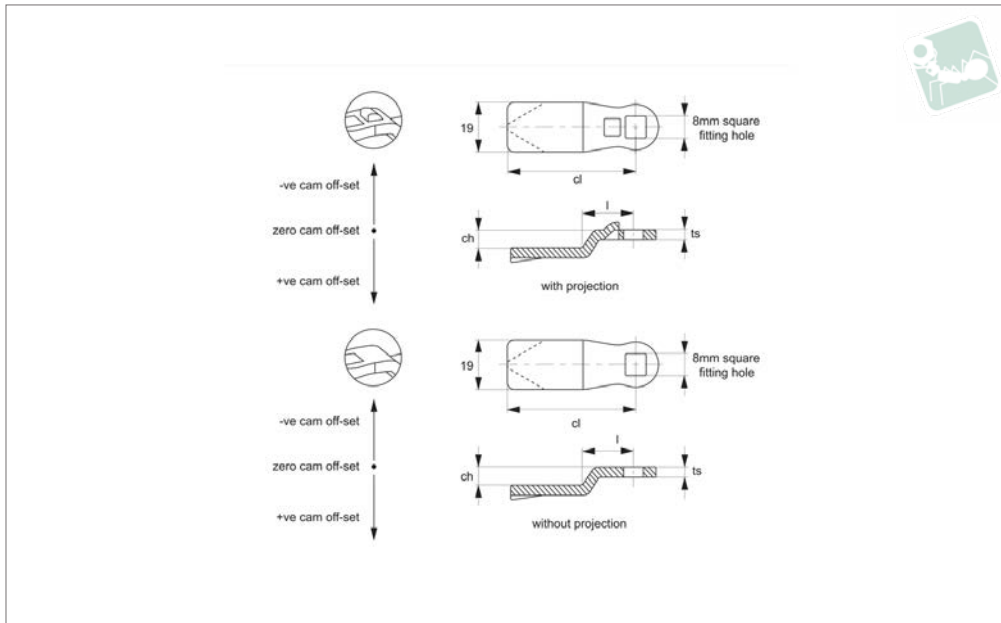

CC0020

LATCHES

Material

Steel, zinc plated.

Technical Notes

Use formula to calculate ch (required cam off-set), and select from product table below;

$ch = h - lh$ where;

ch = required cam off-set/height.

h = grip length (distance between inside of latch face and front of cam).

lh = body length of cam latch/lock to be used (see individual latch/lock product table).

Refer to installation drawing below.

Important Notes

Suitable for Flexi-System latches. „With projection“ type ensures correct location and prevents cam rotating over 45°. See **cam selection chart for specific latch/lock suitability.**

Sold subject to pack quantity.

Order No.	Type	ch	cl	ts	Where lh = 18	Where lh = 18,5	Where lh = 20	Where lh = 24	Where lh = 30	Where lh = 40	Where lh = 50	Where lh = 60
CC0020.M0400	With Projection	0	45	3	18,0	18,5	20,0	24	30	40	50	60
CC0020.M0402	With Projection	2	45	3	20,5	22,0	26,0	32	42	52	62	72
CC0020.M0403	With Projection	3	45	3	21,0	21,5	23,0	27	33	43	53	63
CC0020.M0404	With Projection	4	45	3	22,0	22,5	24,0	28	34	44	54	64
CC0020.M0406	With Projection	6	45	3	24,0	24,5	26,0	30	36	46	56	66
CC0020.M0407	With Projection	7	45	3	25,0	25,5	27,0	31	37	47	57	67
CC0020.M0408	With Projection	8	45	3	26,0	26,5	28,0	32	38	48	58	68
CC0020.M0410	With Projection	10	45	3	28,0	28,5	30,0	34	40	50	60	70
CC0020.M0412	With Projection	12	45	3	30,0	30,5	32,0	36	42	52	62	72
CC0020.M0414	With Projection	14	45	3	32,0	32,5	34,0	38	44	54	64	74
CC0020.M0416	With Projection	16	45	3	34,0	34,5	36,0	40	46	56	66	76
CC0020.M0418	With Projection	18	45	3	36,0	36,5	38,0	42	48	58	68	78
CC0020.M0420	With Projection	20	45	3	38,0	38,5	40,0	44	50	60	70	80
CC0020.M1402	With Projection	-2	45	3	16,0	16,5	18,0	22	28	38	48	58
CC0020.M5300	W/o Projection	0	35	4	18,0	18,5	20,0	24	30	40	50	60
CC0020.M5302	W/o Projection	2	35	4	20,0	20,5	22,0	26	32	42	52	62
CC0020.M5304	W/o Projection	4	35	4	22,0	22,5	24,0	28	34	44	54	64
CC0020.M5306	W/o Projection	6	35	4	24,0	24,5	26,0	30	36	46	56	66
CC0020.M5310	W/o Projection	10	35	4	28,0	28,5	30,0	34	40	50	60	70
CC0020.M5400	W/o Projection	0	45	3	18,0	18,5	20,0	24	30	40	50	60
CC0020.M5402	W/o Projection	2	45	3	20,0	20,5	22,0	26	32	42	52	62
CC0020.M5404	W/o Projection	4	45	3	22,0	22,5	24,0	28	34	44	54	64
CC0020.M5406	W/o Projection	6	45	3	24,0	24,5	26,0	30	36	46	56	66
CC0020.M5407	W/o Projection	7	45	3	25,0	25,5	27,0	31	37	47	57	67
CC0020.M5408	W/o Projection	8	45	3	26,0	26,5	28,0	32	38	48	58	68
CC0020.M5410	W/o Projection	10	45	3	28,0	28,5	30,0	34	40	50	60	70
CC0020.M5412	W/o Projection	12	45	3	30,0	30,5	32,0	36	42	52	62	72
CC0020.M5414	W/o Projection	14	45	3	32,0	32,5	34,0	38	44	54	64	74
CC0020.M5416	W/o Projection	16	45	3	34,0	34,5	36,0	40	46	56	66	76
CC0020.M5418	W/o Projection	18	45	3	36,0	36,5	38,0	42	48	58	68	78



Order No.	Type	ch	cl	ts	Where lh = 18	Where lh = 18,5	Where lh = 20	Where lh = 24	Where lh = 30	Where lh = 40	Where lh = 50	Where lh = 60
CC0020.M5420	W/o Projection	20	45	3	38,0	38,5	40,0	44	50	60	70	80
CC0020.M6302	W/o Projection	-2	35	4	16,0	16,5	18,0	22	28	38	48	64
CC0020.M6402	W/o Projection	-2	45	3	16,0	16,5	18,0	22	28	38	48	58
CC0020.M6404	W/o Projection	-4	45	4	14,0	14,5	16,0	20	26	36	46	56
CC0020.M6406	W/o Projection	-6	45	4	12,0	12,5	14,0	18	24	34	44	54
CC0020.M6408	W/o Projection	-8	45	4	10,5	12,0	16,0	22	32	42	52	52

LATCHES

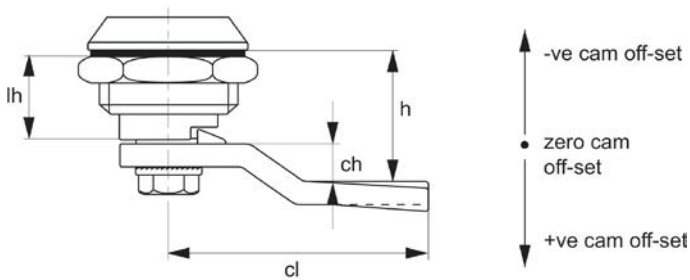



Single Point Cams - Flexi-System

for cam latches and locks - stainless steel - 8 x 8 Sq.

Latches

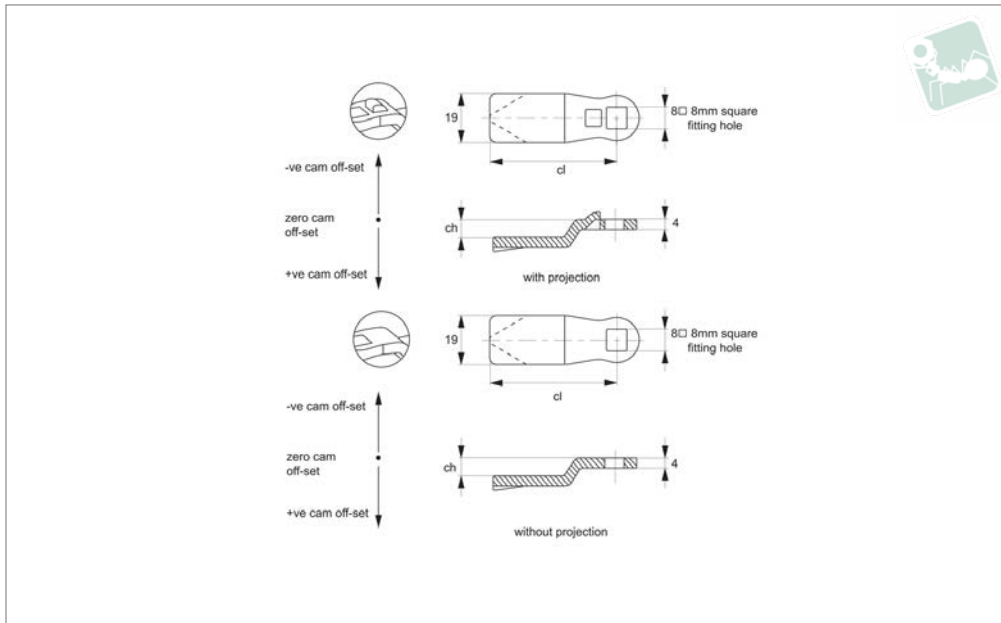

CC0022

LATCHES

Material

Stainless steel, AISI 304.

Technical Notes

Use formula to calculate ch (required cam off-set), and select from product table below;

$ch = h - lh$ where;

ch = required cam off-set/height.

h = grip length (distance between inside of latch face and front of cam).

lh = body length of cam latch/lock to be used (see individual latch/lock product table).

Refer to installation drawing below.

Important Notes

Suitable for Flexi-System latches. „With projection“ type ensures correct location and prevents cam rotating over 45°. See **cam selection chart for specific latch/lock suitability.**

Sold subject to pack quantity.

Order No.	Type	ch	cl	Where lh = 18 h =	Where lh = 18,5 h =
CC0022.M0400	With Projection	0	45	18	18.5
CC0022.M0420	Without Projection	0	45	18	18.5
CC0022.M0402	With Projection	2	45	20	20.5
CC0022.M0423	Without Projection	2	45	20	20.5
CC0022.M0404	With Projection	4	45	22	22.5
CC0022.M0424	Without Projection	4	45	22	22.5
CC0022.M0406	With Projection	6	45	24	24.5
CC0022.M0426	Without Projection	6	45	24	24.5
CC0022.M0408	With Projection	8	45	26	26.5
CC0022.M0428	Without Projection	8	45	26	26.5
CC0022.M0410	With Projection	10	45	28	28.5
CC0022.M0430	Without Projection	10	45	28	28.5
CC0022.M0412	With Projection	12	45	30	30.5
CC0022.M0432	Without Projection	12	45	30	30.5
CC0022.M0434	Without Projection	14	45	32	32.5
CC0022.M0436	Without Projection	16	45	34	34.5
CC0022.M0438	Without Projection	18	45	36	36.5
CC0022.M0500	With Projection	20	45	38	38.5
CC0022.M0520	Without Projection	20	45	38	38.5
CC0022.M0002	Without Projection	-2	45	16	16.5

Order No.	Where lh = 20 h =	Where lh = 25 h =	Where lh = 30 h =	Where lh = 40 h =	Where lh = 50 h =	Where lh = 60 h =
CC0022.M0400	20	25	30	40	50	60
CC0022.M0420	20	25	30	40	50	60
CC0022.M0402	22	27	32	42	52	62
CC0022.M0423	22	27	32	42	52	62
CC0022.M0404	24	29	34	44	54	64
CC0022.M0424	24	29	34	44	54	64
CC0022.M0406	26	31	36	46	56	66
CC0022.M0426	26	31	36	46	56	66

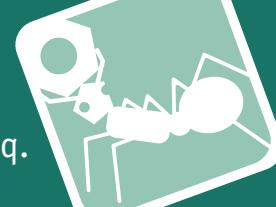

Order No.	Where lh = 20 h =	Where lh = 25 h =	Where lh = 30 h =	Where lh = 40 h =	Where lh = 50 h =	Where lh = 60 h =
CC0022.M0408	28	33	38	48	58	68
CC0022.M0428	28	33	38	48	58	68
CC0022.M0410	30	35	40	50	60	70
CC0022.M0430	30	35	40	50	60	70
CC0022.M0412	32	37	42	52	62	72
CC0022.M0432	32	37	42	52	62	72
CC0022.M0434	34	39	44	54	64	74
CC0022.M0436	36	41	46	56	66	76
CC0022.M0438	38	43	48	58	68	78
CC0022.M0500	40	45	50	60	70	80
CC0022.M0520	40	45	50	60	70	80
CC0022.M0002	18	23	28	38	48	58



Single Point Cams - Steel

for adjustable grip compression cam latches

Latches

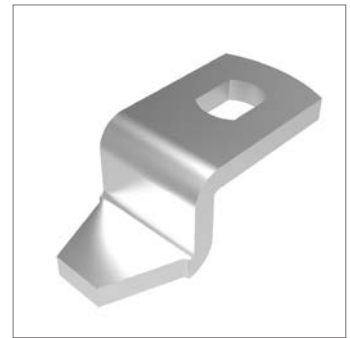
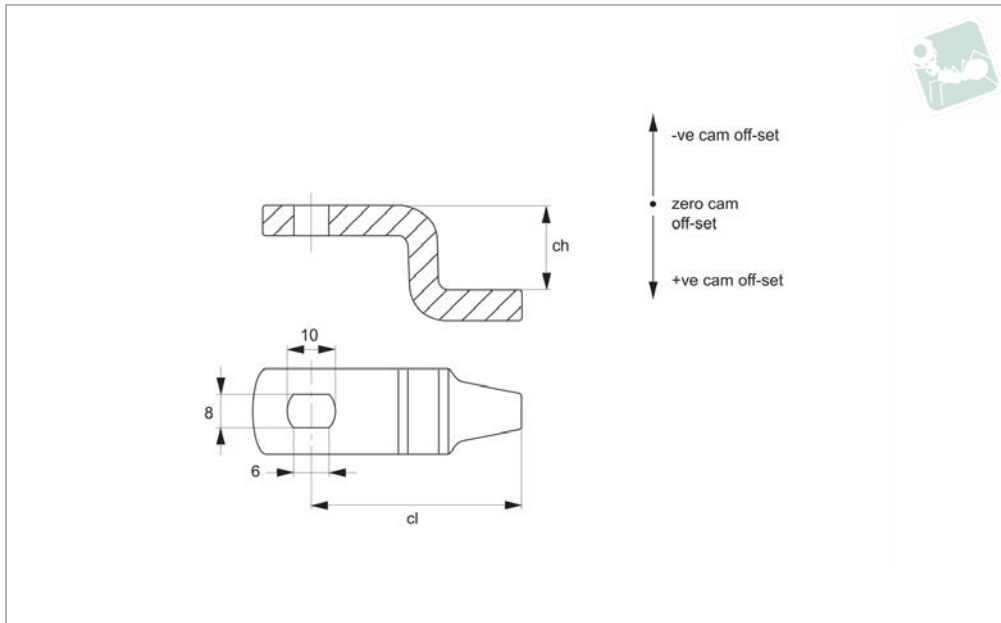

CC0030

LATCHES

Material

Steel, zinc plated.

Technical Notes

Use formula to calculate ch (required cam off-set), and select from product table below;

$ch = h - lh$ where;

ch = required cam off-set/height.

h = grip length (distance between inside of

latch face and front of cam).

lh = body length of cam latch/lock to be used (see individual latch/lock product table).

Refer to installation drawing below.

Important Notes

Suitable for adjustable grip compression cam latches CC0802, CC0810, , .

See cam selection chart for specific

latch/lock suitability.

Installation hole is rectangular 6mmx4mm.

Please note due to design of the single point cam, it is not possible to use +ve offset cam in reverse/upside down as it results in a clash with the body of the cam latch- making it inoperable.

Order No.	ch	cl	Where lh = 32
CC0030.M0300	0	33	32
CC0030.M0314	14	33	46
CC0030.M0327	27	33	59

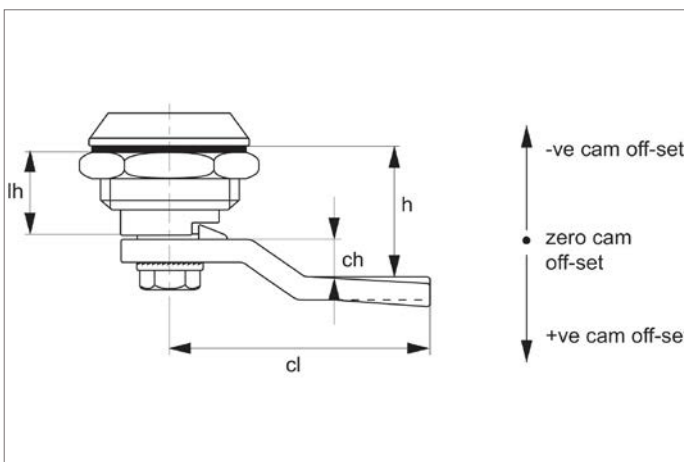

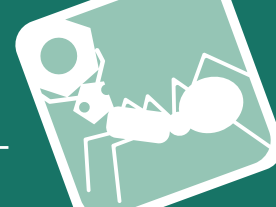

CC0034

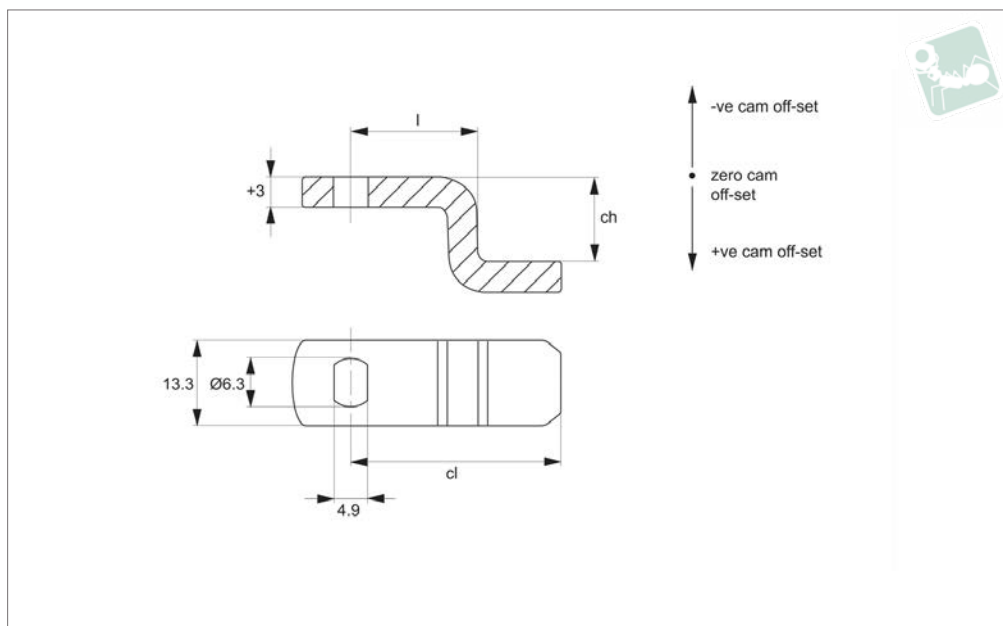

Material

Steel, zinc plated.

Technical Notes

Use formula to calculate ch (required cam off-set), and select from product table below;

ch = h - lh where;

ch = required cam off-set/height.

h = grip length (distance between inside of

latch face and front of cam).

lh = body length of cam latch/lock to be used (see individual latch/lock product table).

Refer to installation drawing above.

Important Notes

Suitable for adjustable grip mini compression cam latches A1660 and A1666. **See cam selection chart for specific latch/**

lock suitability.

Sold subject to pack quantity.

Installation hole is rectangular 6mmx4mm.

Please note due to design of the single point cam, it is not possible to use +ve offset cam in reverse/upside down as it results in a clash with the body of the cam latch- making it inoperable.

Order No.	Type	ch	cl	l	ts	Where lh = 22,5 min. h =
CC0034.M0300	+ve offset	0	23	10	2.8	22.5
CC0034.M0301	+ve offset	1	23	10	2.8	23.5
CC0034.M0303	+ve offset	4	23	10	2.8	26.5
CC0034.M0307	+ve offset	7	23	10	2.8	29.5
CC0034.M0310	+ve offset	10	23	10	2.8	32.5
CC0034.M0313	+ve offset	13	23	10	2.8	35.5
CC0034.M0316	+ve offset	16	23	10	2.8	38.5
CC0034.M0320	+ve offset	20	23	10	2.8	42.5
CC0034.M0323	+ve offset	23	23	10	2.8	45.5



Single Point Cams - Steel

for adjustable grip mini compression cam latches -

Latches

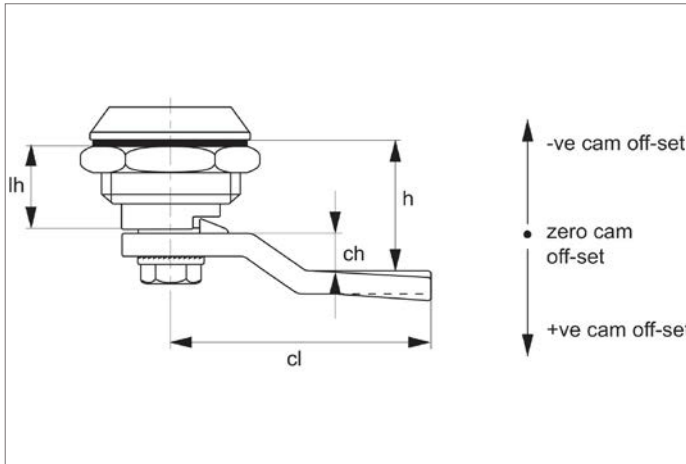

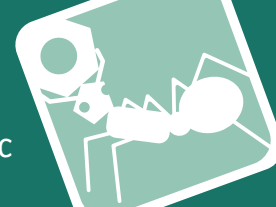

CC0040

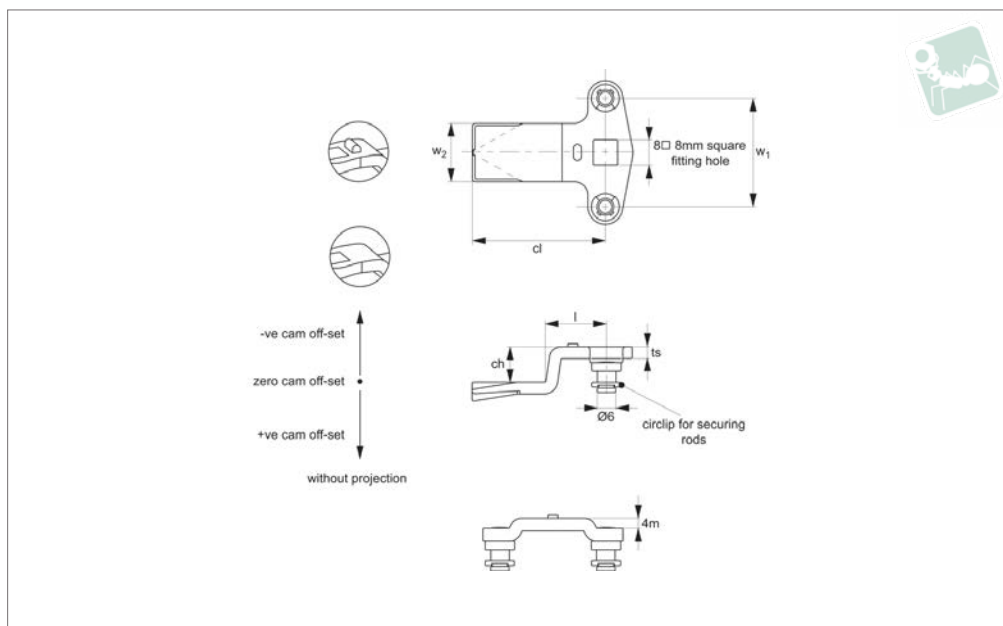

Material

Steel, zinc plated.
Size: 8 x 8 Sq.

Technical Notes

Use formula to calculate **ch** (required cam off-set), and select from product table below;

ch = h - lh where;

ch = required cam off-set/height.

h = grip length (distance between inside of latch face and front of cam).

lh = body length of cam latch/lock to be used (see individual latch/lock product table).

Important Notes

Suitable for Flexi-System latches. „With projection“ type ensures correct location and prevents cam rotating over 45°. **See cam selection chart for specific latch/lock suitability.**

Sold subject to pack quantity.

Order No.	Type	ch	cl	l	ts	w ₁	w ₂
CC0040.M0000	With Projection	0	45	20	4	36	20
CC0040.M0004	With Projection	4	45	20	4	36	20
CC0040.M0008	With Projection	8	45	20	4	36	20
CC0040.M0010	With Projection	10	45	20	4	36	20
CC0040.M0012	With Projection	12	45	20	4	36	20
CC0040.M0014	With Projection	14	45	20	4	36	20
CC0040.M0016	With Projection	16	45	20	4	36	20
CC0040.M0020	With Projection	20	45	20	4	36	20
CC0040.M0022	With Projection	22	45	20	4	36	20
CC0040.M0100	W/o Projection	0	45	20	4	36	20
CC0040.M0104	W/o Projection	4	45	20	4	36	20
CC0040.M0108	W/o Projection	8	45	20	4	36	20
CC0040.M0110	W/o Projection	10	45	20	4	36	20
CC0040.M0120	W/o Projection	12	45	20	4	36	20
CC0040.M0140	W/o Projection	14	45	20	4	36	20
CC0040.M0160	W/o Projection	16	45	20	4	36	20
CC0040.M0200	W/o Projection	20	45	20	4	36	20
CC0040.M0220	W/o Projection	22	45	20	4	36	20

Order No.	Where lh = 18	Where lh = 18,5	Where lh = 20	Where lh = 25	Where lh = 30	Where lh = 40	Where lh = 50	Where lh = 60
	h =	h =	h =	h =	h =	h =	h =	h =
CC0040.M0000	18	18.5	20	25	30	40	50	60
CC0040.M0004	22	22.5	24	29	34	44	54	64
CC0040.M0008	26	26.5	28	33	38	48	58	68
CC0040.M0010	28	28.5	30	35	40	50	60	70
CC0040.M0012	30	30.5	32	37	42	52	62	72
CC0040.M0014	32	32.5	34	39	44	54	64	74
CC0040.M0016	34	34.5	36	41	46	56	66	76
CC0040.M0020	38	38.5	40	45	50	60	70	80
CC0040.M0022	40	40.5	42	47	52	62	72	82



Two Point Cams - Flexi-System

for 3-point latching of cam latches and locks - zinc

Latches

Order No.	Where lh = 18	Where lh = 18,5	Where lh = 20	Where lh = 25	Where lh = 30	Where lh = 40	Where lh = 50	Where lh = 60
	h =	h =	h =	h =	h =	h =	h =	h =
CC0040.M0100	18	18.5	20	25	30	40	50	60
CC0040.M0104	22	22.5	24	29	34	44	54	64
CC0040.M0108	26	26.5	28	33	38	48	58	68
CC0040.M0110	28	28.5	30	35	40	50	60	70
CC0040.M0120	30	30.5	32	37	42	52	62	72
CC0040.M0140	32	32.5	34	39	44	54	64	74
CC0040.M0160	34	34.5	36	41	46	56	66	76
CC0040.M0200	38	38.5	40	45	50	60	70	80
CC0040.M0220	40	40.5	42	47	52	62	72	82

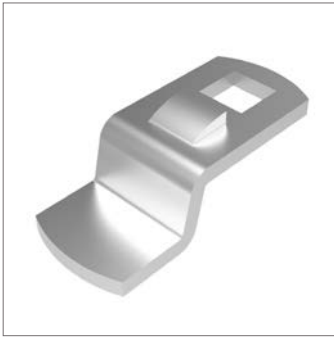

CC0050

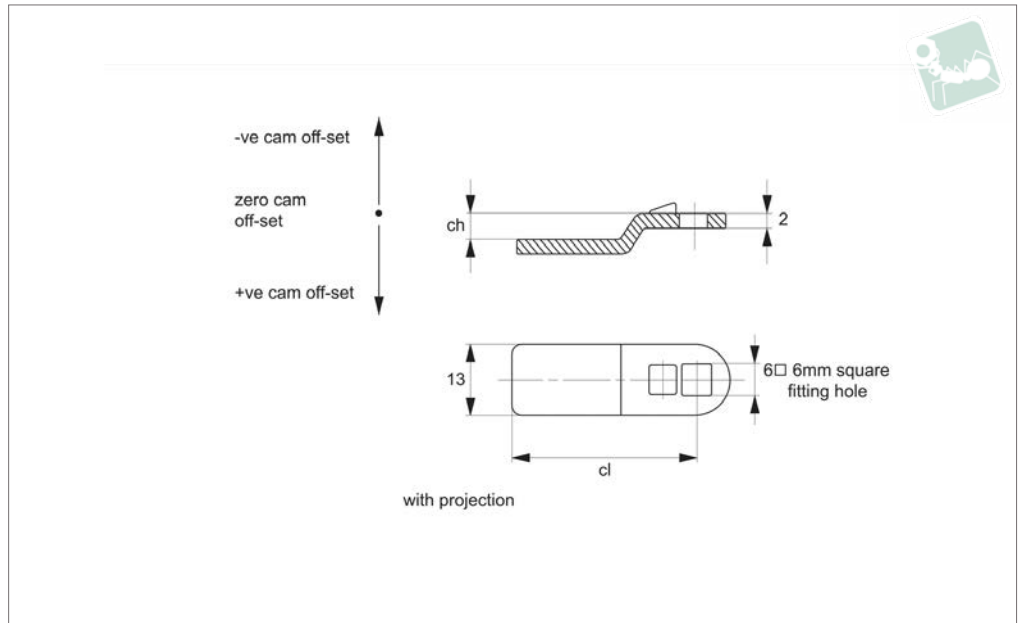

Material

Steel, zinc plated.

Technical Notes

Use formula to calculate ch (required cam off-set), and select from product table below;

$ch = h - lh$ where;

ch = required cam off-set/height.

h = grip length (distance between inside of latch face and front of cam).

lh = body length of cam latch/lock to be used (see individual latch/lock product table).

Refer to installation drawing below.

Important Notes

With projection type ensures correct location and prevents cam rotating over 45° .

See cam selection chart for specific latch/lock suitability.

Sold subject to pack quantity.

Order No.	ch	cl	Where lh = 18 h =	Where lh = 18,5 h =	Where lh = 20 h =	Where lh = 25 h =	Where lh = 30 h =	Where lh = 40 h =	Where lh = 50 h =	Where lh = 60 h =
CC0050.M0200	0	25	18	18,5	20	25	30	40	50	60
CC0050.M0206	6	25	24	24,5	26	31	36	46	56	66
CC0050.M0296	-6	25	12	12,5	14	19	24	34	44	54
CC0050.M0307	7	30	25	25,5	27	32	37	47	57	67

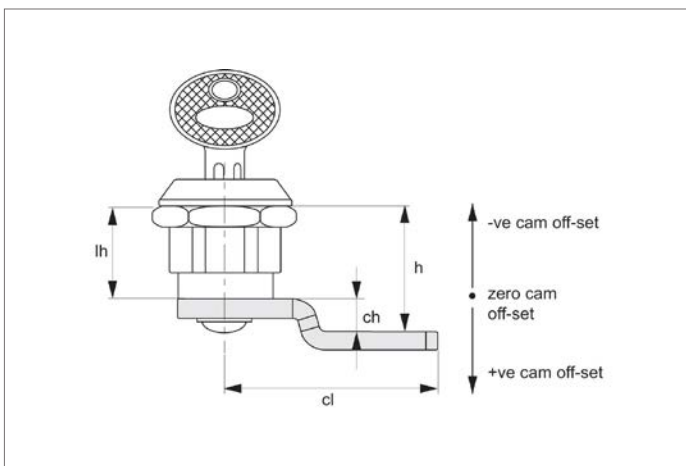



Multi-Point Latching Set

round rod - for cam latches and swing handles

Latches

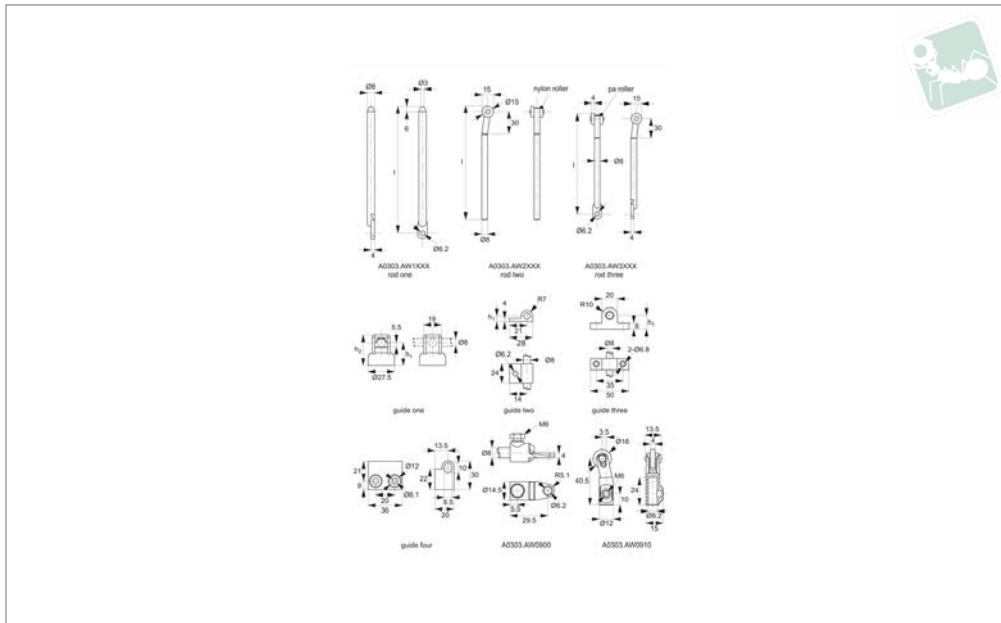

CC0340

LATCHES

Material

Rod: steel, zinc plated. With Nylon or PA6 rollers.

Rod Guides One to Four: polyamide, PA6.

Rod Adaptor and Roller Adaptor: die cast zinc, zinc plated.

Technical Notes

For use with cam latches & locks, making a

full 3-point latching system.

Distance between base of rod and inside of door depends upon height of rod guide selected, see dimension h_1 .

Rod guides: fixed via counter sunk screw or weld-on stud.

Rod adaptor: fits to any length of rod. If rod of different length is required, simply

cut oversized length with a saw.

Cams: see two point cams CC0040 to achieve 3-point locking.

Important Notes

Please order rods, rod guides and rod adaptors separately.

Order No.	Type	Length l	h_1	h_2	Weld screw
CC0340.M0861	Guide One	-	24	32	M 6 x 16
CC0340.M0862	Guide One	-	30	38	M 6 x 20
CC0340.M0863	Guide One	-	34	42	M 6 x 20
CC0340.M0881	Guide Two	-	7	-	-
CC0340.M0882	Guide Three	-	18	-	-
CC0340.M0883	Guide Four	-	22	-	-
CC0340.M0900	Rod Adaptor	-	-	-	-
CC0340.M1060	Rod One	600	-	-	-
CC0340.M1080	Rod One	800	-	-	-
CC0340.M1100	Rod One	1000	-	-	-
CC0340.M2060	Rod Two	600	-	-	-
CC0340.M2080	Rod Two	800	-	-	-
CC0340.M2100	Rod Two	1000	-	-	-
CC0340.M3060	Rod Three	600	-	-	-
CC0340.M3080	Rod Three	800	-	-	-
CC0340.M3100	Rod Three	1000	-	-	-



CC0350

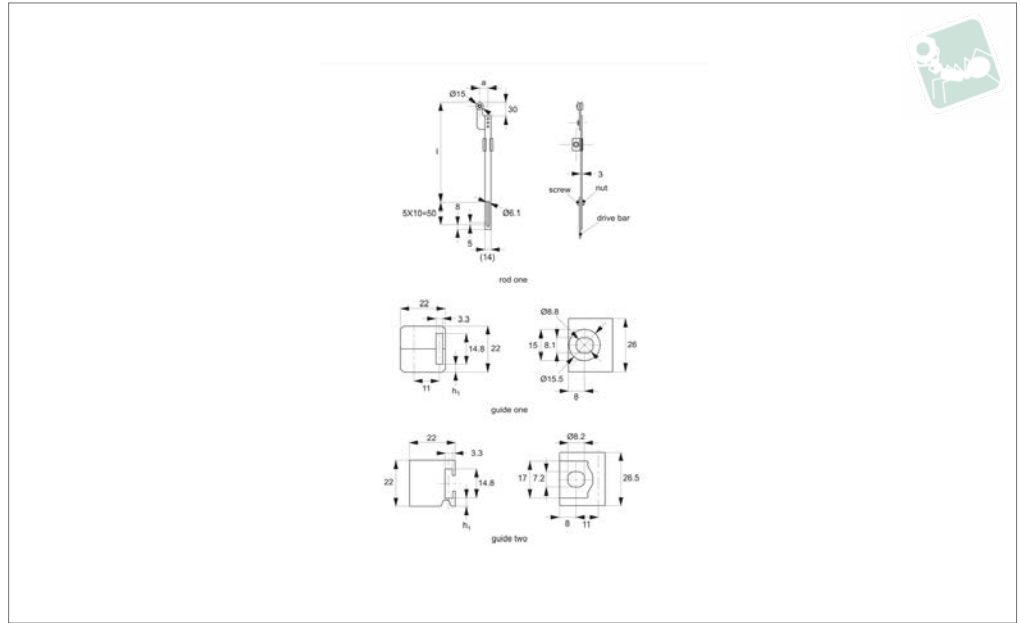

Material

Rod: steel, zinc plated. With nylon or PA6 rollers.

Rod guides One and Two: polyamide, PA6.

Technical Notes

For use with cam latches & locks, making a

full 3-point latching system. Distance between base of rod and inside of door depends upon height of rod guide selected, see dimension h_1 .

Rod guides: fixed via counter sunk screw or weld-on stud.

Cams: see two point cams CC0040 to achieve 3-point locking.

Important Notes

Please order rods and guides separately.

Order No.	Type	Length	a	h_1	Weld screw
CC0350.M1127	Rod One	1000	27.5	-	-
CC0350.M0800	Guide One	-	-	3.6	M 6x16
CC0350.M0820	Guide Two	-	-	3.6	M 6x16



Multi-Point Latching Set

flat rod with locking pins - for cam latches and

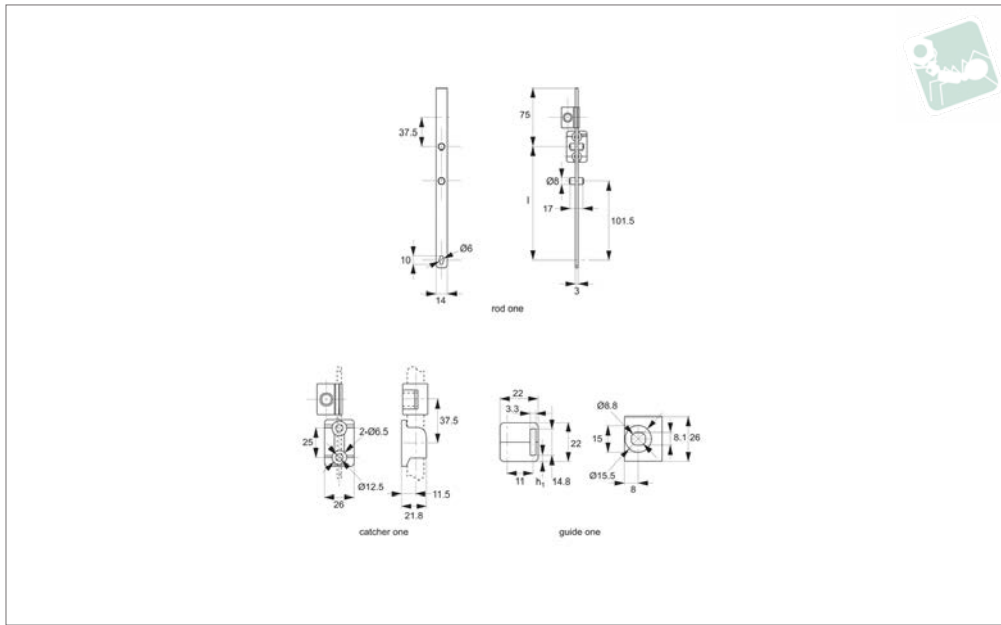

CC0355

LATCHES

Material

Rod: steel, zinc plated.
 Rod Guides One: polyamide, PA6.
 Rod Catcher: die cast zinc, black.

Technical Notes

For use with cam latches & locks, making a

full 3-point latching system. Distance between base of rod and inside of door depends upon height of rod guide selected, see dimension h_1 .

Rod guides: fixed via counter sunk screw or weld-on stud.

Cams: see two point cams CC0040 to achieve 3-point locking.

Important Notes

Please order rods, rod guides and rod catcher separately.

Order No.	Type	Length l	h_1
CC0355.M1070	Rod One	760	-
CC0355.M0900	Rod Catcher	-	-

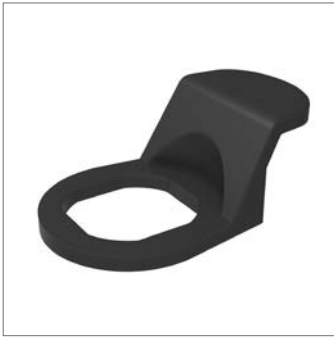

CC0300

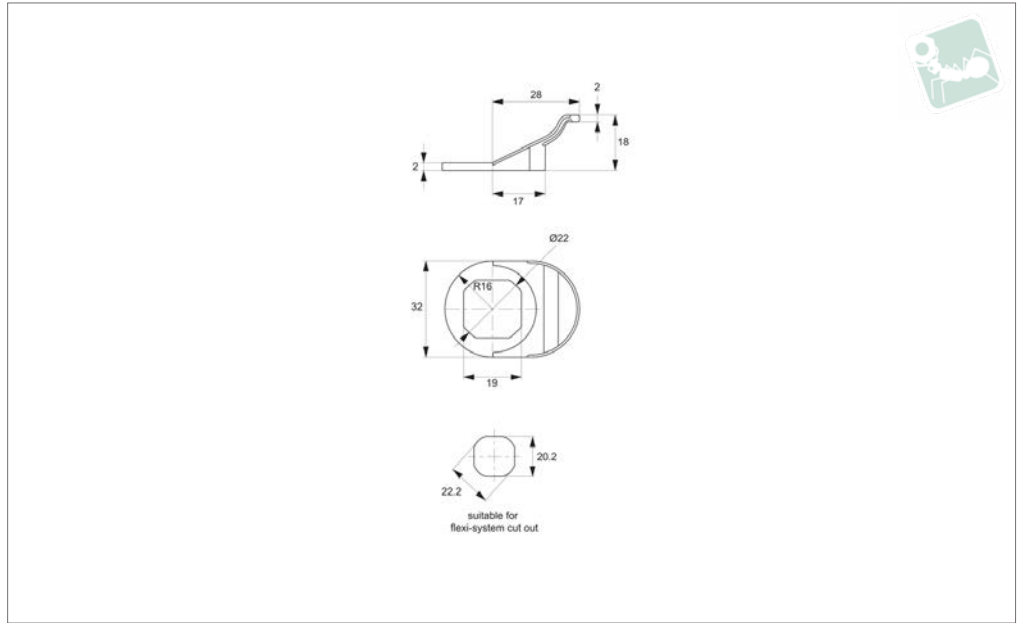

Material

Body: polyamide DIN-EN ISO 1043-1 PA 6 GFR 30, black.

Technical Notes

Suitable for all Flexi-System latches with cut-out of 22,2 dia. / 20,2 square. Please

order cam latch/lock separately, see parts A1002 to A1252.

Tips

Note when finger pull used the cam latch useful body length ,lh' is reduced by 2mm. This is important in relation to

selection of suitable cam.

Important Notes

Sold subject to pack quantity.

Order No.
CC0300.M0028

To suit flexi-system fastener
22,2 Dia Installation Cut Out

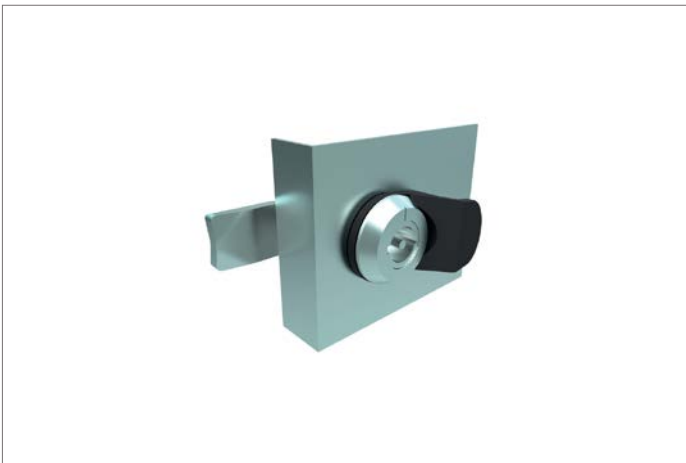



Dust Cap for flexi-system cam latches and locks

Latches

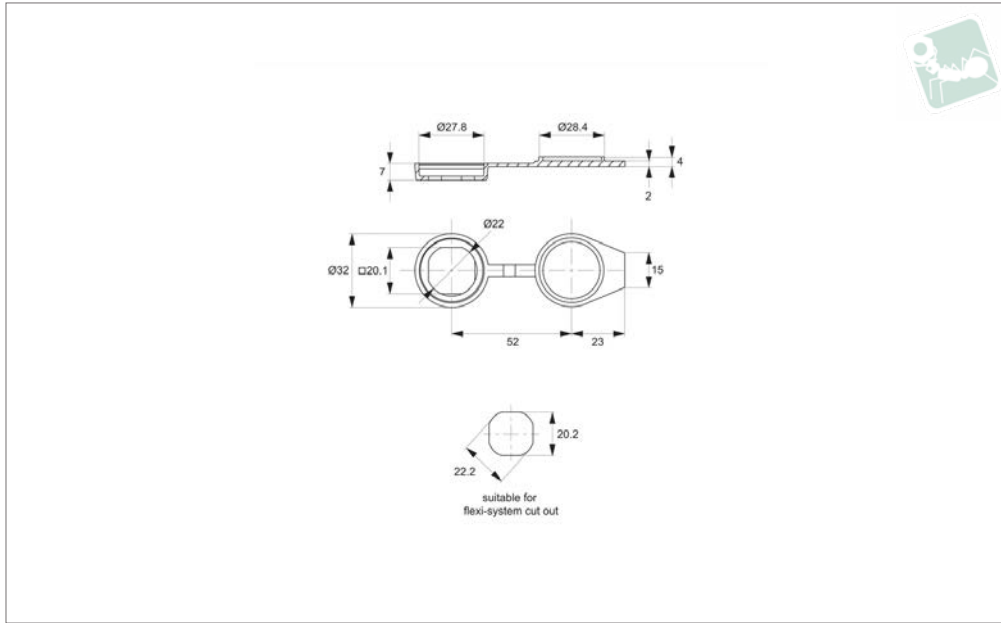

CC0305

LATCHES

Material

Body: polyamide, black.

Technical Notes

Fits all Flexi-System cam latches & locks, and other fasteners with a standard instal-

lation cut out of 22,2 dia / 20,2 square.

Tips

Note when dust cap used the cam latch useful body length ,lh' is reduced by 2mm. This is important in relation to selection of

suitable cam.

Important Notes

Sold subject to pack quantity.

Order No.
CC0305.M0010

Type
Polyamide



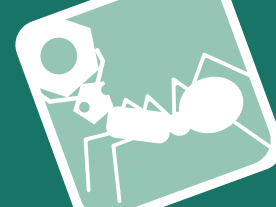

CC0400

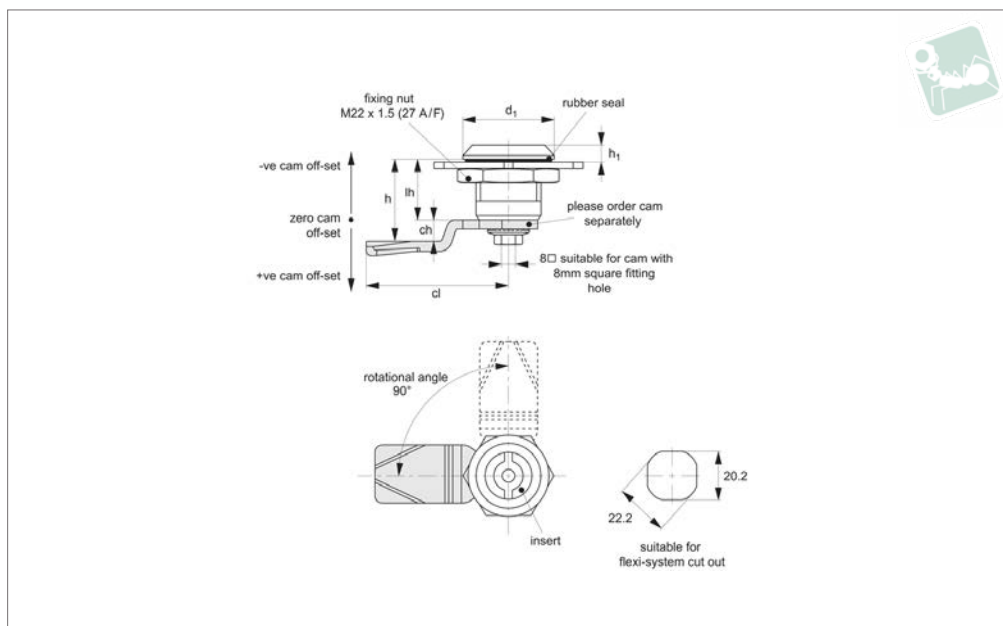

Material

Body & insert: die cast zinc. Finished in chrome plate or black powder coating. Insert fitted with O'ring to achieve IP54 rating. Internal spring provides 1,5mm torsion.

Supplied with: Nut: steel, zinc plated.

Sealing washer: PU and rubber.

Not supplied: CAM nor KEY - order separately.

Technical Notes

Order cam and key separately.

Cams: see suitable cam CC0020, and CC0040. Select „without projection“ cam type.

Dimensions ch and cl relate to cam. Use formula to calculate ch (required cam off-set), and refer to cam selection chart;

ch = h - lh where;

ch = required cam off-set/height.

h = grip length (distance between inside of latch face and front of cam).

lh = body length of cam latch/lock to be used (see product table below).

Keys: see CC0010.

Rods & Guides: to achieve 3-point latching - CC0340, CC0350, CC0355.

Important Notes

Extended body version - CC0460.

Sold subject to pack quantity.

Order No.	Finish	Insert driver	d ₁	h ₁	lh
CC0400.M0010	Chrome Plated	Square 7	28	6	18
CC0400.M0310	Black Coated	Square 7	28	6	18
CC0400.M0020	Chrome Plated	Square 8	28	6	18
CC0400.M0320	Black Coated	Square 8	28	6	18
CC0400.M0040	Chrome Plated	Triangle 7	28	6	18
CC0400.M0340	Black Coated	Triangle 7	28	6	18
CC0400.M0050	Chrome Plated	Triangle 8	28	6	18
CC0400.M0350	Black Coated	Triangle 8	28	6	18
CC0400.M0060	Chrome Plated	3mm Double Bit	28	6	18
CC0400.M0360	Black Coated	3mm Double Bit	28	6	18
CC0400.M0070	Chrome Plated	4mm Double Bit	28	6	18
CC0400.M0370	Black Coated	4mm Double Bit	28	6	18
CC0400.M0080	Chrome Plated	Slotted (2x4)	28	6	18
CC0400.M0380	Black Coated	Slotted (2x4)	28	6	18



Cam Latches - Flexi-System

insert driver - fixed grip - plastic

Latches

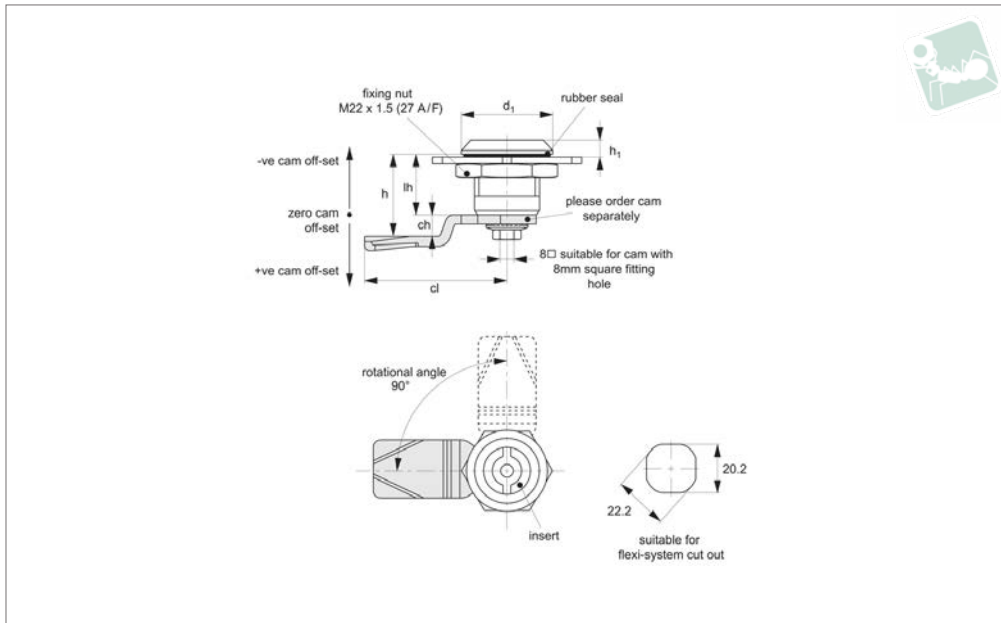

CC0410

LATCHES

Material

Body: polyamide plastic, black.
 Insert: zinc alloy, black coated. Fitted with O'ring to achieve IP54 rating. Internal spring provides 1,5mm torsion.
Supplied with: Nut: steel, zinc plated.
 Sealing washer: PU & Rubber.
Not supplied: CAM nor KEY - order separately.

Technical Notes

Order cam and key separately.

Cams: see suitable cam CC0020, and CC0040. Select „without projection“ cam type.

Dimensions ch and cl relate to cam. Use formula to calculate ch (required cam off-set), and refer to cam selection chart;

$ch = h - lh$ where;

ch = required cam off-set/height.

h = grip length (distance between inside of latch face and front of cam).

lh = body length of cam latch/lock to be

used (see product table below).

Keys: see CC0010.

Rods & Guides: to achieve 3-point latching - CC0340, CC0350, CC0355.

Important Notes







An inexpensive alternative to stainless steel, where water or other solutions may cause corrosion.

Sold subject to pack quantity.

Order No.	Insert driver	d_1	h_1	lh
CC0410.M0010	Square 7	28	6	18
CC0410.M0020	Square 8	28	6	18
CC0410.M0040	Triangle 7	28	6	18
CC0410.M0050	Triangle 8	28	6	18
CC0410.M0060	3mm Double Bit	28	6	18
CC0410.M0070	4mm Double Bit	28	6	18
CC0410.M0080	Slotted (2x4)	28	6	18



Available insert drivers:

Square 7	Square 8	Triangle 7	Triangle 8	3mm Double Bit	4mm Double Bit	2 x 4mm Slotted
						



Cam Latches - Flexi-System

insert driver - fixed grip - stainless steel

Latches

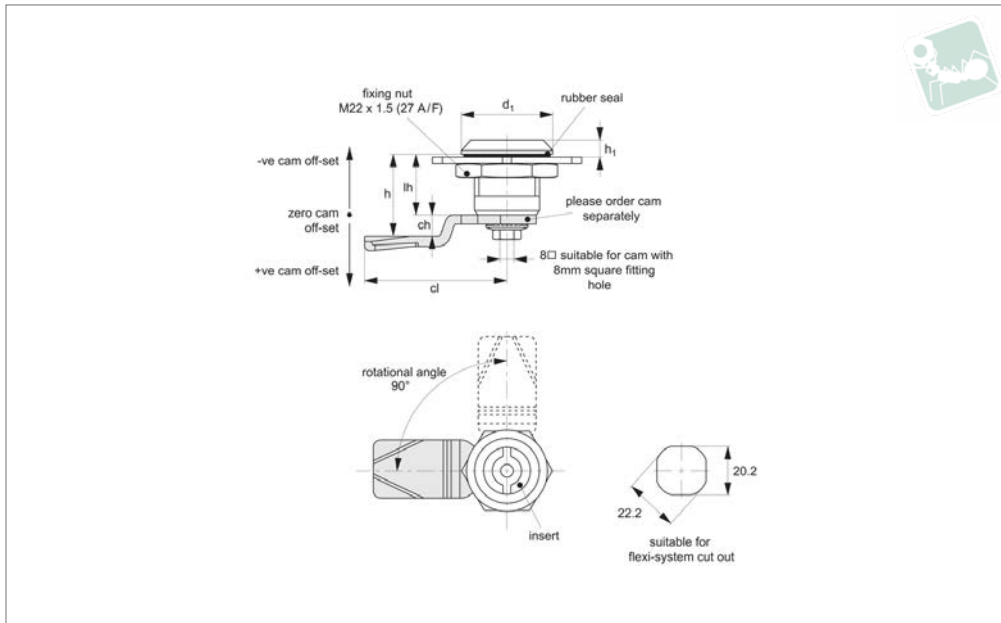

CC0420

LATCHES

Material

Body & Insert: stainless steel, AISI 304.
Insert fitted with O'ring to achieve IP54 rating. Internal spring provides 1,5mm torsion.

Supplied with: Nut: stainless steel.
Sealing washer: PU & Rubber.

Not supplied: CAM nor KEY - order separately.

Technical Notes

Order cam and key separately.

Cams: see suitable cam CC0022. Select „without projection“ cam type.

Dimensions ch and cl relate to cam. Use formula to calculate ch (required cam off-set), and refer to cam selection chart;

ch = h - lh where;

ch = required cam off-set/height.

h = grip length (distance between inside of latch face and front of cam).

lh = body length of cam latch/lock to be used (see product table below).

Keys: see CC0010.

Rods & Guides: to achieve 3-point latching - CC0340, CC0350, CC0355.

Order No.	Insert driver	d ₁	h ₁	lh
CC0420.M0020	Square 8	28	6	18
CC0420.M0040	Triangle 7	28	6	18
CC0420.M0050	Triangle 8	28	6	18
CC0420.M0060	3mm Double Bit	28	6	18
CC0420.M0070	4mm Double Bit	28	6	18

Available insert drivers:

Square 8	Triangle 7	Triangle 8	3mm Double Bit	4mm Double Bit

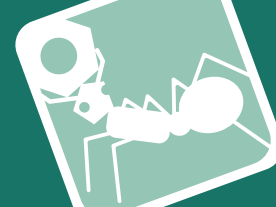

CC0430

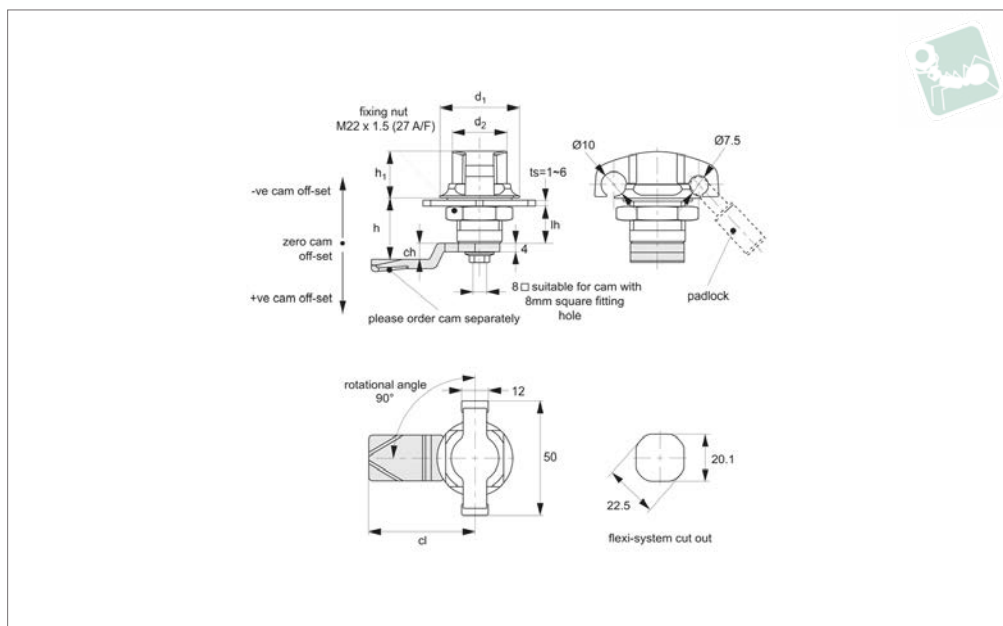

Material

Body & Handle: die cast zinc, pocked black powder or chrome plated.

Not supplied: CAM - order separately.

Technical Notes

Order cam separately.

Cams: see suitable cam CC0020, and CC0040. Select „without projection“ cam type.

Dimensions ch and cl relate to cam. Use

formula to calculate ch (required cam off-set), and refer to cam selection chart;

ch = h - lh where;

ch = required cam off-set/height.

h = grip length (distance between inside of latch face and front of cam).

lh = body length of cam latch/lock to be used (see product table below).

Rods & Guides: to achieve 3-point latching - CC0340, CC0350, CC0355.

Tips

The wing knob can be locked by two sizes of padlock max. shackle dia. 7.5mm or 10mm. See technical diagram (padlock not supplied).

Panel thickness (ts) is 1 to 6mm max.

Important Notes

Sold subject to pack quantity.

Order No.	Type	d ₁	h ₁	d ₂	lh	Finish
CC0430.M0310	Black Coated	33	19	21	18	black coated





Cam Latches - Flexi-System

fixed grip - finger handle

Latches

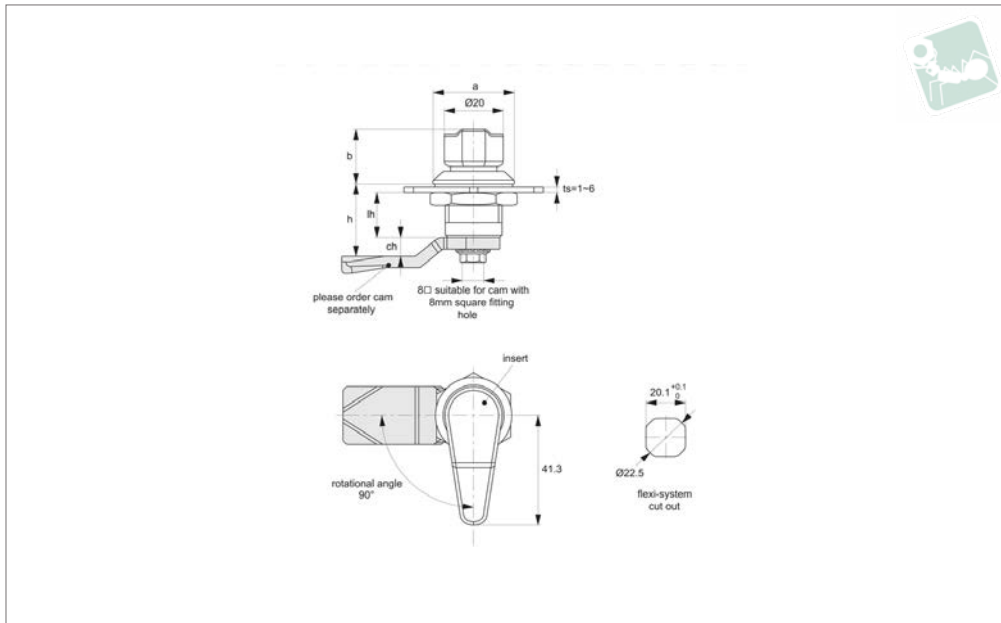

CC0440

LATCHES

Material

Type one: Body: die cast zinc, black powder coated.

Handle: polyamide, black.

Type two: Body & handle: polyamide, black.

Technical Notes

Order cam separately.

Cams: see suitable cam CC0020, and CC0040. Select „without projection“ cam

type.

Dimensions ch and cl relate to cam. Use formula to calculate ch (required cam off-set), and refer to cam selection chart;

ch = h - lh where;

ch = required cam off-set/height.

h = grip length (distance between inside of latch face and front of cam).

lh = body length of cam latch/lock to be used (see product table below).

Rods & Guides: to achieve 3-point latching - CC0340, CC0350, CC0355.

Tips

Finger knob actuates lock, and also acts as a handle.

Important Notes

Sold subject to pack quantity.

Order No.	Type	a	b	lh
CC0440.M0318	One Zinc	28	18	18
CC0440.M0328	One Zinc	28	18	28
CC0440.M0362	One Zinc	28	18	62
CC0440.M0518	Two Polyamide	28	18	18
CC0440.M0536	Two Polyamide	28	18	36

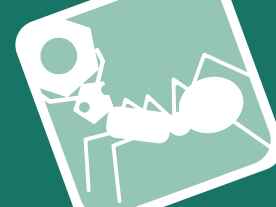

CC0460

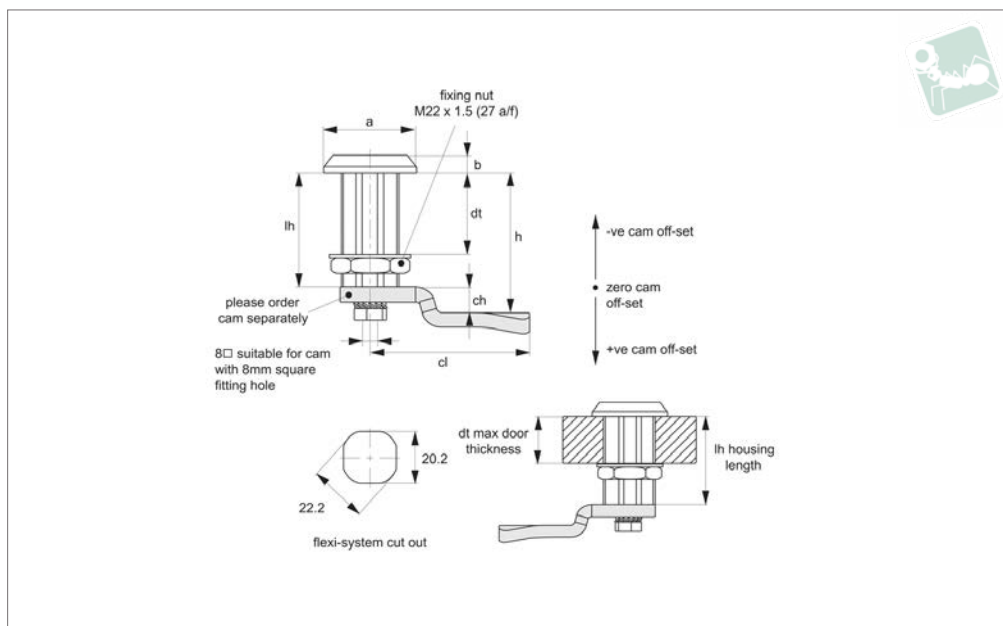

Material

Body & insert: die cast zinc, chrome plated.
Insert fitted with O’ring to achieve IP54 rating.

Supplied With: Nut: steel, zinc plated.

Sealing washer: PU & Rubber.

Not supplied: CAM nor KEY - order separately.

Technical Notes

Order cam and key separately.

Cams: see suitable cam CC0020, and CC0040. Select „without projection“ cam

type.

Dimensions ch and cl relate to cam. Use formula to calculate ch (required cam off-set), and refer to cam selection chart;

ch = h - lh where;

ch = required cam off-set/height.

h = grip length (distance between inside of latch face and front of cam).

lh = body length of cam latch/lock to be used (see product table below).

Keys: see CC0010.

Rods & Guides: to achieve 3-point latching

- CC0340, CC0350, CC0355.

Tips

Ideal for air conditioning units, sound-proof or isolation doors, as well as wooden panels. Insert quarter-turn opening or closing.

Slotted insert driver does not require a key. Simply use a flat head screwdriver to actuate.

Important Notes

Sold subject to pack quantity.

Order No.	Insert driver	lh	dt	a	b
CC0460.M0011	Square 7	28	20	28	4
CC0460.M0021	Square 8	28	20	28	4
CC0460.M0041	Triangle 7	28	20	28	4
CC0460.M0051	Triangle 8	28	20	28	4
CC0460.M0061	3mm Double Bit	28	20	28	4
CC0460.M0071	4mm Double Bit	28	20	28	4
CC0460.M0081	Slotted (2x4)	28	20	28	4
CC0460.M0311	Square 7	36	30	28	4
CC0460.M0321	Square 8	36	30	28	4
CC0460.M0341	Triangle 7	36	30	28	4
CC0460.M0351	Triangle 8	36	30	28	4
CC0460.M0361	3mm Double Bit	36	30	28	4
CC0460.M0371	4mm Double Bit	36	30	28	4
CC0460.M0381	Slotted (2x4)	36	30	28	4
CC0460.M0511	Square 7	62	50	28	4
CC0460.M0521	Square 8	62	50	28	4
CC0460.M0551	Triangle 8	62	50	28	4
CC0460.M0561	3mm Double Bit	62	50	28	4
CC0460.M0571	4mm Double Bit	62	50	28	4
CC0460.M0581	Slotted (2x4)	62	50	28	4



Mini Cam Latches

insert driver - fixed grip

Latches

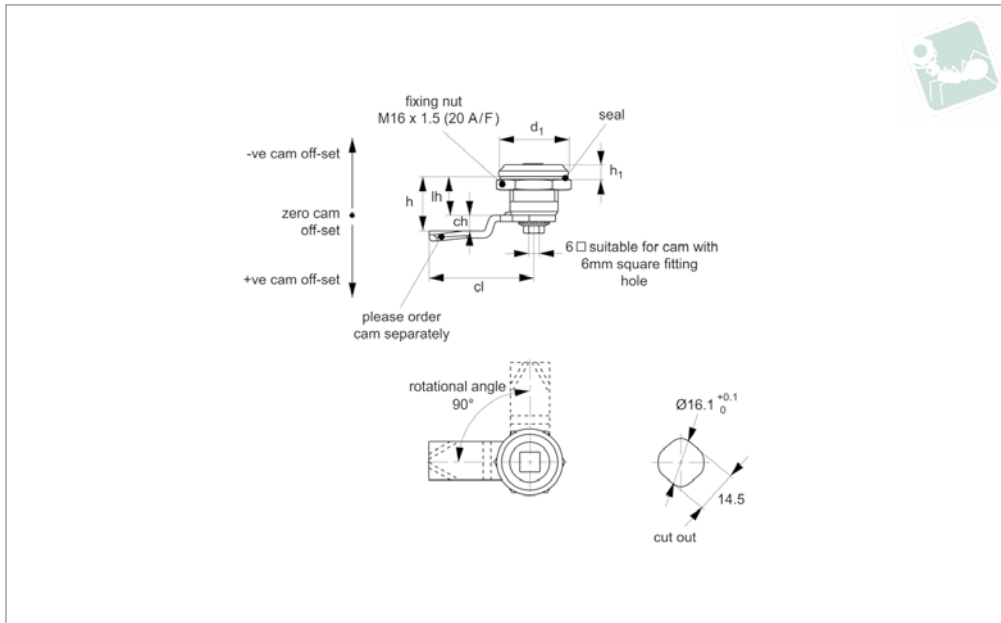

CC0500

LATCHES

Material

Type one: Body & insert: die cast zinc, chrome plated or black powder coated.

Supplied with: Keys: two per lock.

Not supplied: CAM - order separately.

Technical Notes

Order cam and key separately.

Cams: see suitable cam CC0050. Select „with projection“ cam type to prevent cam

rotating over 45°.

Dimensions ch and cl relate to cam. Use formula to calculate ch (required cam off-set), and refer to cam selection chart;

$ch = h - lh$ where;

ch = required cam off-set/height.

h = grip length (distance between inside of latch face and front of cam).

lh = body length of cam latch/lock to be

used (see product table below).

Keys: see CC0010.

Tips

Mini cam latches for any application; securing doors, cabinets etc. Quarter-turn opening or closing.

Important Notes

Sold subject to pack quantity.

Order No.	Insert driver	Finish	d_1	h_1	lh
CC0500.M0006	Square 6	Chrome	20	4	12.5
CC0500.M0078	Slot (2x4)	Chrome	20	4	12.5
CC0500.M0306	Square 6	Black Coated	20	4	12.5
CC0500.M0378	Slot (2x4)	Black Coated	20	4	12.5



CC0502

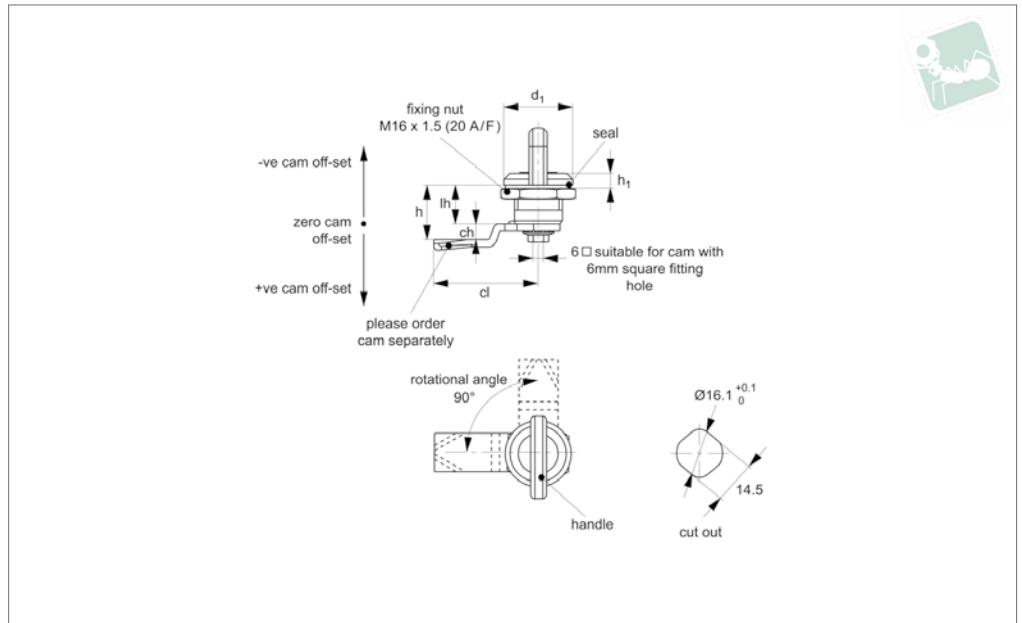

Material

Body & insert: die cast zinc, chrome plated or black powder coated.

Handle: black plastic, PA6.

Not supplied: CAM - order separately.

Technical Notes

Order cam separately.

Cams: see suitable cam CC0050. Select „with projection“ cam type to prevent cam

rotating over 45°.

Dimensions ch and cl relate to cam. Use formula to calculate ch (required cam off-set), and refer to cam selection chart;

ch = h - lh where;

ch = required cam off-set/height.

h = grip length (distance between inside of latch face and front of cam).

lh = body length of cam latch/lock to be

used (see product table below).

Tips

Wing knob actuates lock, and also acts as knob/handle.

Important Notes

Sold subject to pack quantity.

Order No.	Handle	Body	d ₁	h ₁	lh
CC0502.M0120	Black Plastic	Black Powder	20	4	12.5



Compression Latches - Flexi-System

insert driver - fixed grip - zinc

Latches

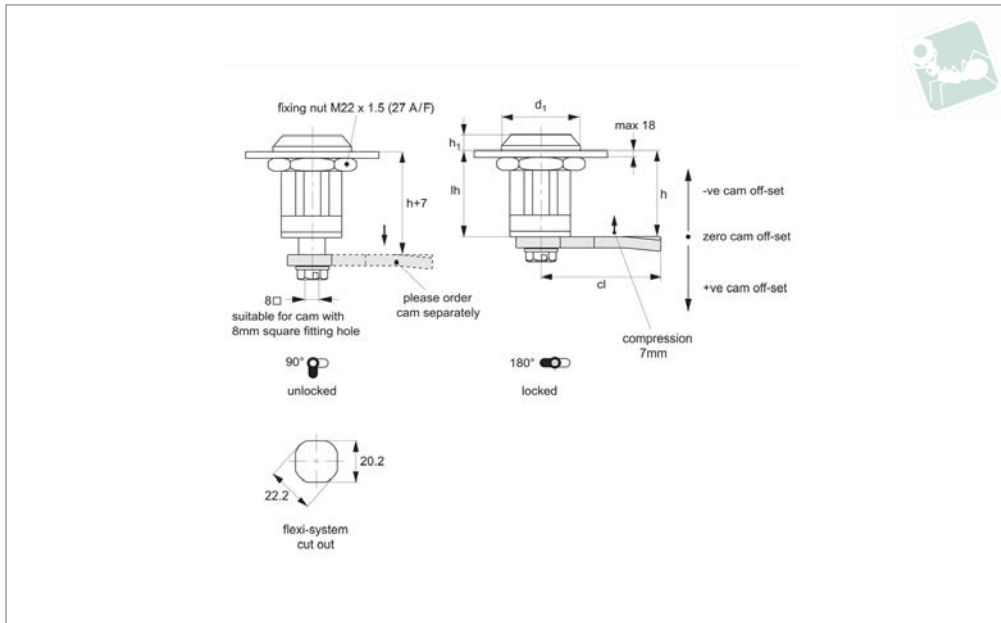

CC0800

LATCHES

Material

Body & insert: die cast zinc, finished in chrome plate or black powder coating.
Insert fitted with O'ring to provide IP54 rating.

Handle: polyamide.

Not supplied: CAM nor KEY - order separately.

Technical Notes

Order cam and key separately.

Cams: see suitable cam CC0020 and .

Select „without projection“ cam type.

Dimensions ch and cl relate to cam. Use formula to calculate ch (required cam off-set), and refer to cam selection chart;

$ch = h - lh$ where;

ch = required cam off-set/height.

h = grip length (distance between inside of latch face and front of cam).

lh = body length of cam latch/lock to be used (see product table below).

Keys: see CC0010.

Tips

Compression locks provide sealing of enclosures to reduce vibration and to provide noise isolation.

Action:

From unlocked position, first 90° turn moves the cam to the locking position. Turn lock 180° to engage compression, cam moves to final fixing position.

Provides a 7mm compression stroke.

Order No.	Finish	Insert driver	d_1	h_1	lh
CC0800.M0020	Chrome Plated	Square 8	28	5.5	31
CC0800.M0320	Black Coated	Square 8	28	5.5	31
CC0800.M0040	Chrome Plated	Triangle 7	28	5.5	31
CC0800.M0340	Black Coated	Triangle 7	28	5.5	31
CC0800.M0050	Chrome Plated	Triangle 8	28	5.5	31
CC0800.M0350	Black Coated	Triangle 8	28	5.5	31
CC0800.M0080	Chrome Plated	Slot (2x4)	28	5.5	31
CC0800.M0380	Black Coated	Slot (2x4)	28	5.5	31
CC0800.M0085	Chrome Plated	Hexagon 8	28	5.5	31
CC0800.M0385	Black Coated	Hexagon 8	28	5.5	31

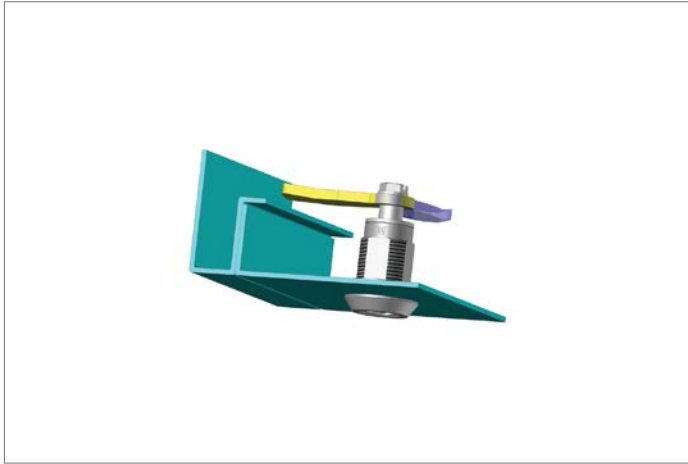



Compression Latches - Flexi-System

insert driver - fixed grip - stainless steel

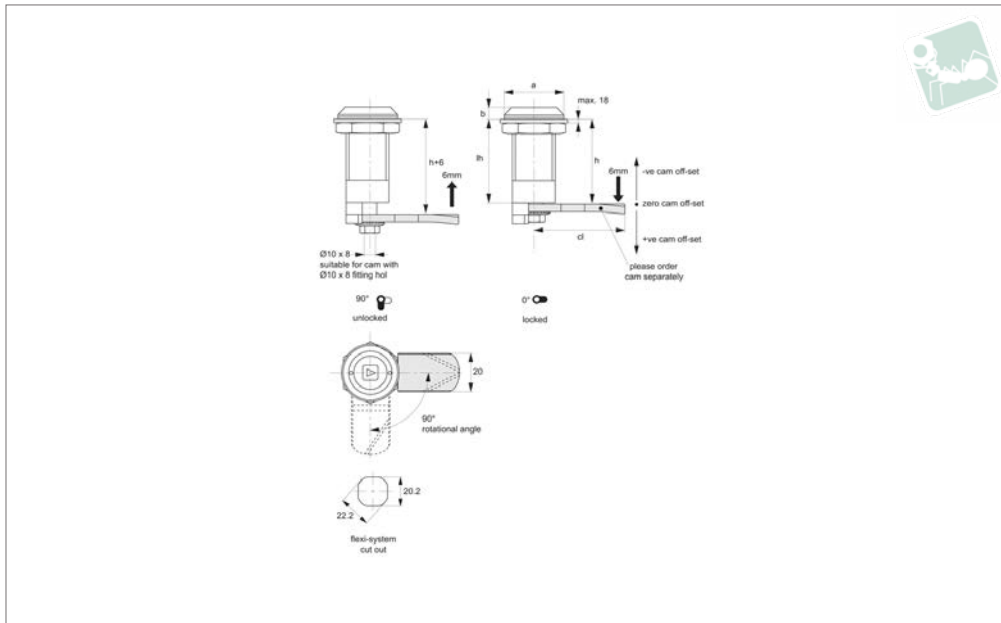

CC0802

LATCHES

Material

Body & insert: stainless steel, AISI 304.
 Insert fitted with O'ring to provide IP54 rating.
 Shaft: steel, white zinc plated.
Not supplied: KEY - order separately.

Technical Notes

Order cam and key separately.
Cams: see suitable cam CC0030 and A0233.
 Select „without projection“ cam type.
 Dimensions ch and cl relate to cam. Use

formula to calculate ch (required cam off-set), and refer to cam selection chart;
 $ch = h - lh$ where;
ch = required cam off-set/height.
h = grip length (distance between inside of latch face and front of cam).
lh = body length of cam latch/lock to be used (see product table below).
Keys: see CC0010.

Tips

Compression locks provide sealing of

enclosures to reduce vibration and to provide noise isolation.

Action:

From unlocked position, first 90° turn moves the cam to the locking position. Turn lock 180° to engage compression, cam moves to final fixing position.
Provides a 6mm compression stroke.

Order No.	Insert driver	Type	a	b	lh
CC0802.M0020	Square 8	Fixed Grip	28	5	38
CC0802.M0050	Triangle 8	Fixed Grip	28	5	38

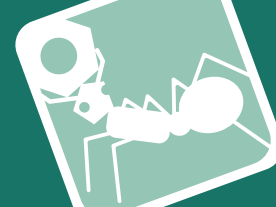

CC0810

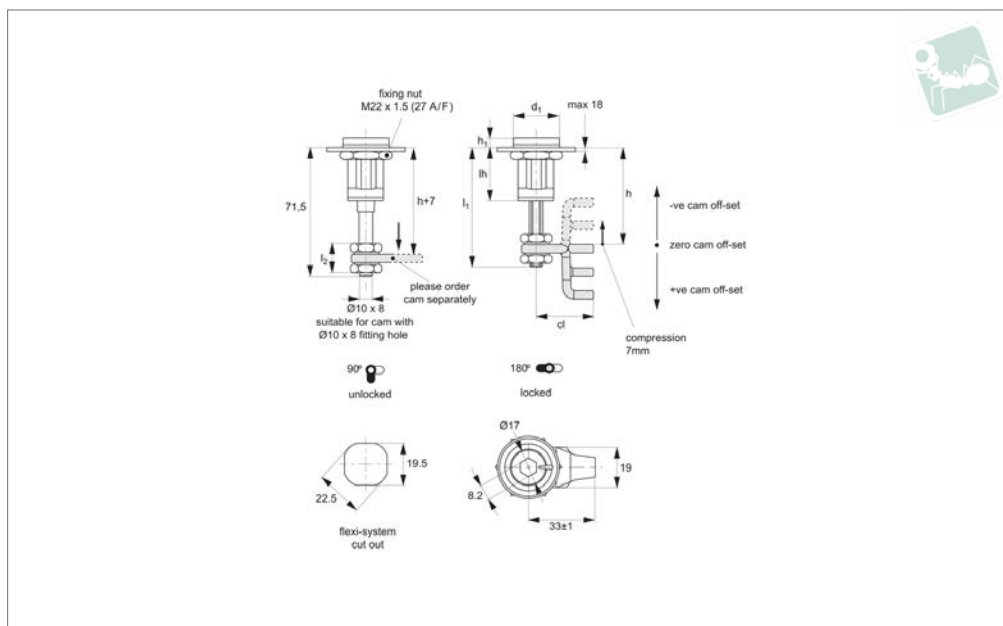

Material

Body & insert: die cast zinc, chrome plate or black coated finish. Insert fitted with O'ring to provide IP54 rating.

Handle: polyamide.

Not supplied: CAM nor KEY - order separately.

Technical Notes

Order cam and key separately.

Cams: see suitable cam CC0030 and A0233.

Select „without projection“ cam type.

Dimensions ch and cl relate to cam. Use

formula to calculate ch (required cam off-set), and refer to cam selection chart;

ch = h - lh where;

ch = required cam off-set/height.

h = grip length (distance between inside of latch face and front of cam).

lh = body length of cam latch/lock to be used (see product table below).

Keys: see CC0010.

Tips

Compression locks provide sealing of enclosures to reduce vibration and to

provide noise isolation. Adjustable grip type has an extended stem which can be cut in length to best suit your application.

Action:

From unlocked position, first 90° turn moves the cam to the locking position. Turn lock 180° to engage compression, cam moves to final fixing position.

Provides a 7mm compression stroke.

Important Notes

Cam: quarter turn to open or close. Locking function.

Order No.	Finish	Insert driver	d ₁	h ₁	lh	l ₁	l ₂ useful thread
CC0810.M0020	Chrome Plated	Square 8	28	4.5	32	64.5	15
CC0810.M0320	Black Coated	Square 8	28	4.5	32	64.5	15
CC0810.M0040	Chrome Plated	Triangle 7	28	4.5	32	64.5	15
CC0810.M0340	Black Coated	Triangle 7	28	4.5	32	64.5	15
CC0810.M0050	Chrome Plated	Triangle 8	28	4.5	32	64.5	15
CC0810.M0350	Black Coated	Triangle 8	28	4.5	32	64.5	15
CC0810.M0080	Chrome Plated	Slot (2x4)	28	4.5	32	64.5	15
CC0810.M0380	Black Coated	Slot (2x4)	28	4.5	32	64.5	15
CC0810.M0085	Chrome Plated	Hexagon 8	28	4.5	32	64.5	15
CC0810.M0385	Black Coated	Hexagon 8	28	5.5	31	64.5	15