

## ST0010

STAYS & HINGES

**Material**

Steel, zinc plated.

table. Ideal for screw or weld-on mounting.

**Technical Notes**

Left or right hand specific, please refer to

Order No.	Hand	l <sub>1</sub>
ST0010.M0008	Right	202
ST0010.M0006	Right	135
ST0010.M0010	Right	292
ST0010.M0106	Left	135
ST0010.M0108	Left	202
ST0010.M0110	Left	292



**ST0012**

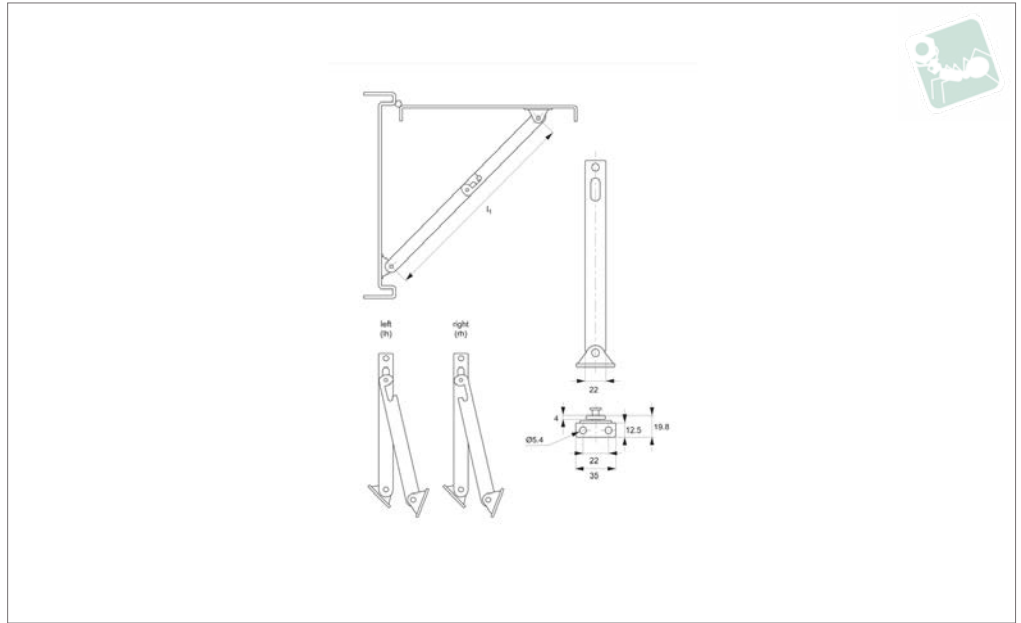

**Material**

Steel, zinc plated.

**Technical Notes**

Right or left handed, please refer to table.  
Ideal for screw or weld-on mounting.

Order No.	Hand	$l_1$
ST0012.M0006	Right	135
ST0012.M0106	Left	135
ST0012.M0008	Right	202
ST0012.M0108	Left	202
ST0012.M0010	Right	292
ST0012.M0110	Left	292

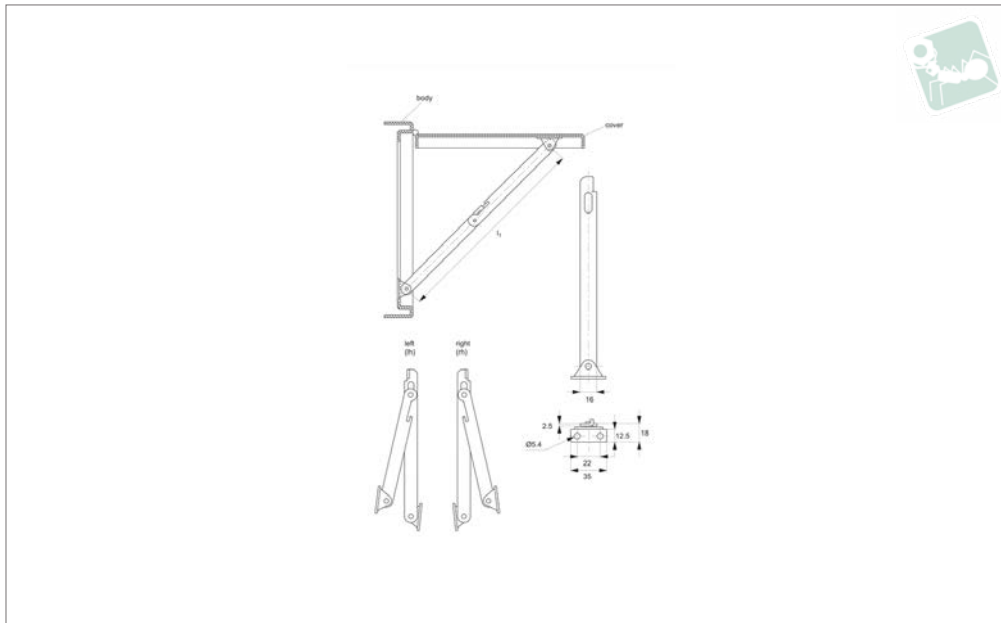

**ST0014**

STAYS & HINGES

**Material**

Stainless steel, AISI 304.

**Technical Notes**

Right or left handed, please refer to table.  
Ideal for screw or weld-on mounting.

Order No.	Hand	$l_1$
ST0014.M0006	Right	135
ST0014.M0008	Right	202
ST0014.M0010	Right	292
ST0014.M0108	Left	202
ST0014.M0106	Left	135
ST0014.M0110	Left	292



**ST0016**

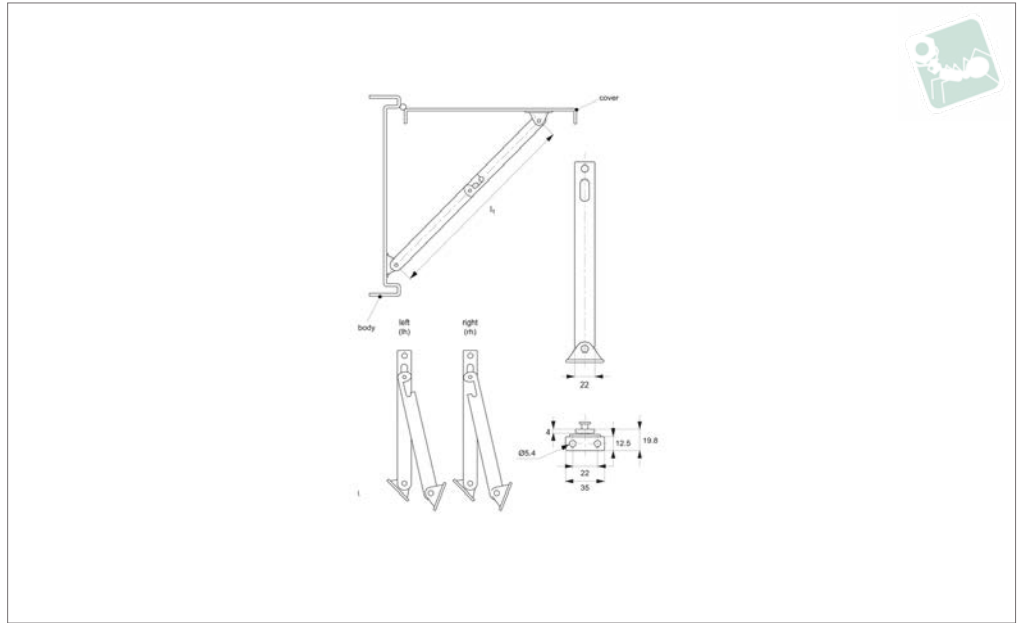

**Material**

Stainless steel, AISI 304.

**Technical Notes**

Right or left handed, please refer to table.  
Ideal for screw or weld-on mounting.

Order No.	Hand	l <sub>1</sub>
ST0016.M0006	Right	135
ST0016.M0008	Right	202
ST0016.M0010	Right	292
ST0016.M0106	Left	135
ST0016.M0108	Left	202
ST0016.M0110	Left	292



# Door Stays

stainless steel - 100° opening

## Stays & Hinges

STAYS & HINGES

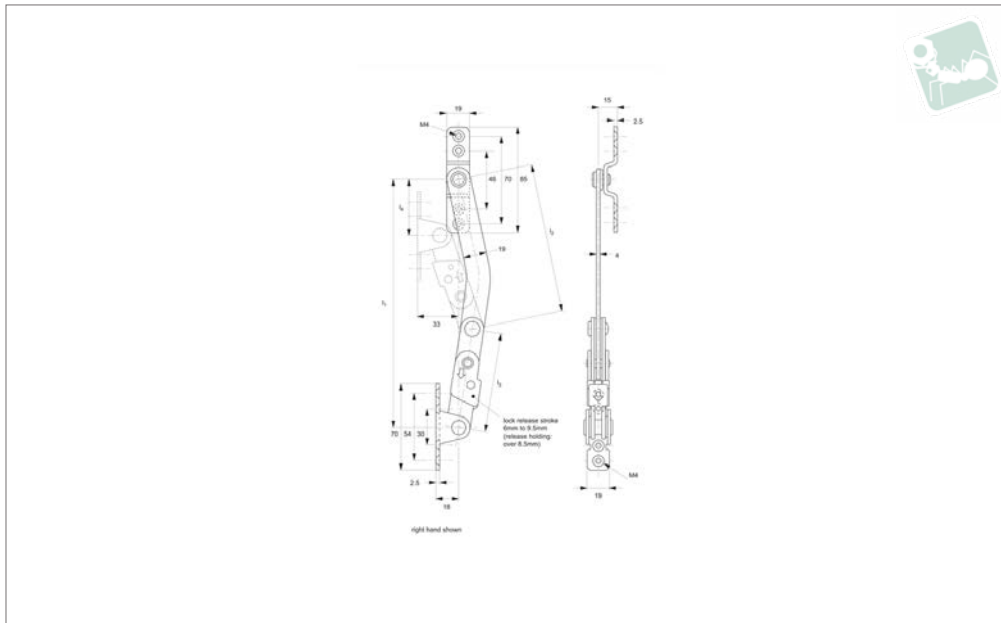

**ST0500**

**Material**

Stainless steel, AISI 304, polished.

**Technical Notes**

Mechanically locks door at fully open posi-

tion. Slide the locking lever to release stay. Lever will remain in unlocked position until the door is returned to fully open position.

Order No.	Type	$l_1$	a	b	c	d	$l_2$	$l_3$	$l_4$	Weight g
ST0500.M0110	Left	200	121	200	93	36	121	80	45	290
ST0500.M0010	Right	200	121	200	93	36	121	80	45	290
ST0500.M0120	Left	280	161	280	145	40	161	120	44	340
ST0500.M0020	Right	280	161	280	145	40	161	120	44	340

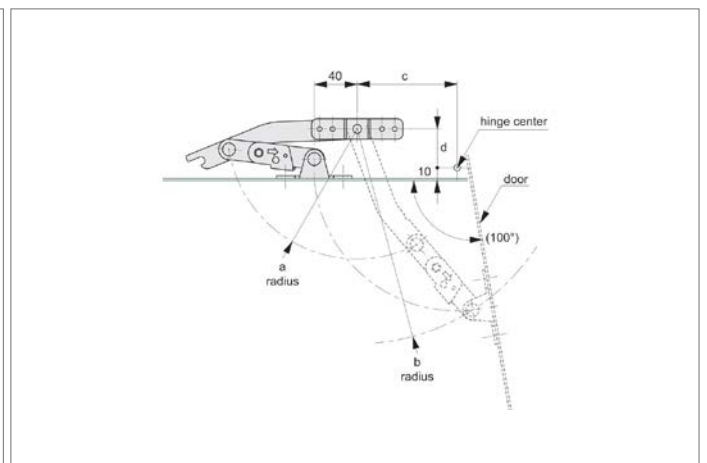
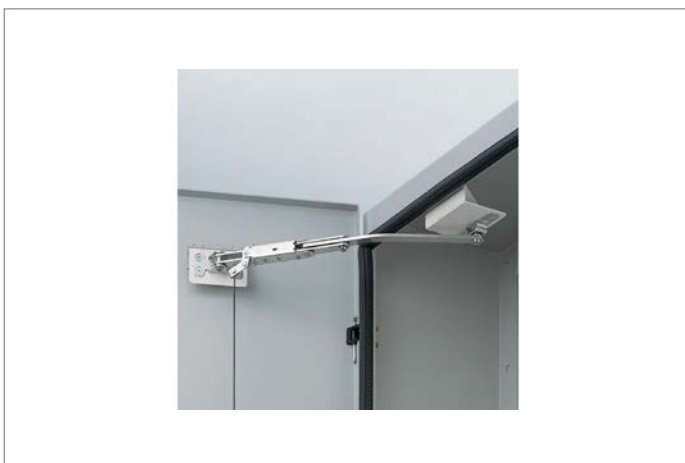

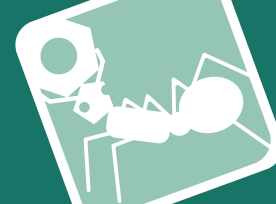

**ST0510**

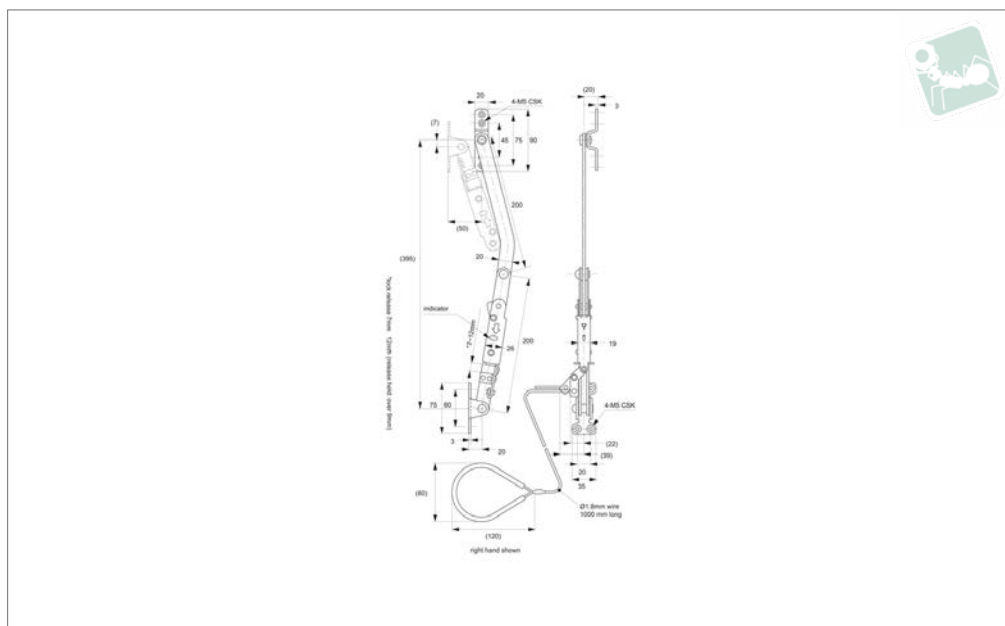

**Material**

All parts from stainless steel, AISI 304.

available, with or without lock release wire.

**release wire.**  
**Easy to install.**

**Technical Notes**

Suitable for heavy duty horizontal door applications. Right and left versions

**Tips**

**Locks automatically in open position, can be released via lock release or optional**

Order No.	Type	Finish	Comp. force kg max.	Tensile force kg max.
ST0510.M0010	Right	With Release Wire	60	150
ST0510.M0020	Right	Without Release Wire	60	150
ST0510.M0110	Left	With Release Wire	60	150
ST0510.M0120	Left	Without Release Wire	60	150



# Surface Mount - Leaf Hinges

screw mount - zinc

## Stays & Hinges

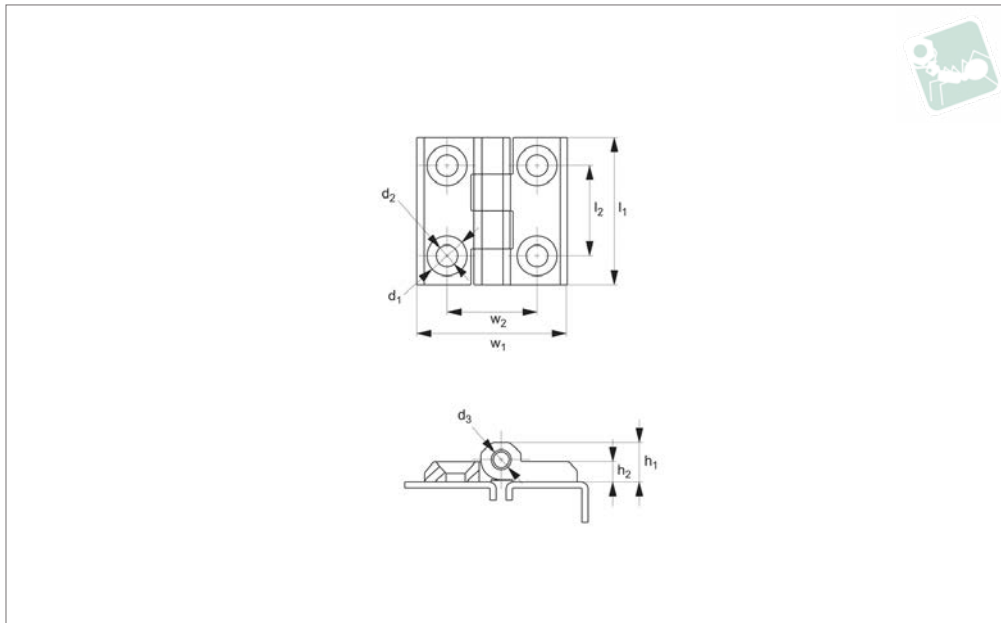

### HH0010

STAYS & HINGES

#### Material

##### Black Coated

Body: die cast zinc, black powder coated.  
Pin: steel, nickel plated.

#### Chrome

Body: die cast zinc, chrome plated.  
Pin: steel, nickel plated.

#### Technical Notes

For plain/flush mounted doors, as well as electrical panels and covers. Opening angle 180°.

Order No.	Finish	Size	$h_1$	$h_2$	$l_1$	$l_2$	$w_1$	$w_2$	$d_1$	$d_2$	90° Angled stress kN	Axial load $F_x$ N max.	Axial stress kN	Radial load $F_x$ N max.	Radial stress kN
HH0010.M0040	Black Coated	40 x 40	9,0	5,0	40	25	40	25	10,2	5,3	2,00	1,2	1,45	1,0	2,1
HH0010.M0050	Black Coated	50 x 50	11,5	6,0	50	30	50	30	12,5	6,3	2,45	1,3	2,10	1,2	3,5
HH0010.M0060	Black Coated	60 x 60	15,0	8,0	60	36	60	36	16,5	8,4	4,40	1,8	3,20	1,5	6,0
HH0010.M0057	Black Coated	50 x 76	11,5	6,0	50	30	76	56	12,5	6,3	1,25	1,2	1,30	1,1	3,0
HH0010.M0612	Black Coated	60x120	15,0	8,0	60	36	120	88	12,5	6,8	1,50	1,2	1,30	1,1	4,5



HH0012

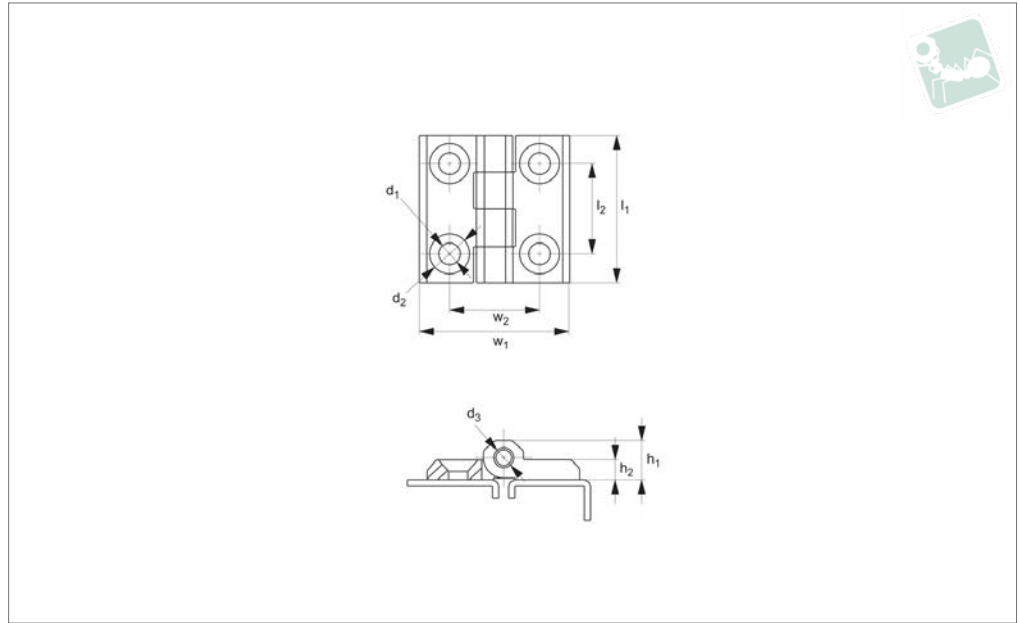

**Material**

Body: polyamide.  
Pin: steel, nickel plated.

**Technical Notes**

For plain/flush mounted doors, as well as electrical panels and covers. Opening

angle 180°.

Order No.	Size	$h_1$	$h_2$	$l_2$	$w_1$	$w_2$	$F_x$ kN	$F_y$ kN	$d_1$	$d_2$	$d_3$
HH0012.M0040	40 x 40	9.8	5	25	40	25	-	-	10.5	5.3	6
HH0012.M0050	50 x 50	11.5	5	30	50	30	1.2	1.3	12.5	6.3	6





# Surface Mount - Leaf Hinges

screw mount - stainless steel

## Stays & Hinges

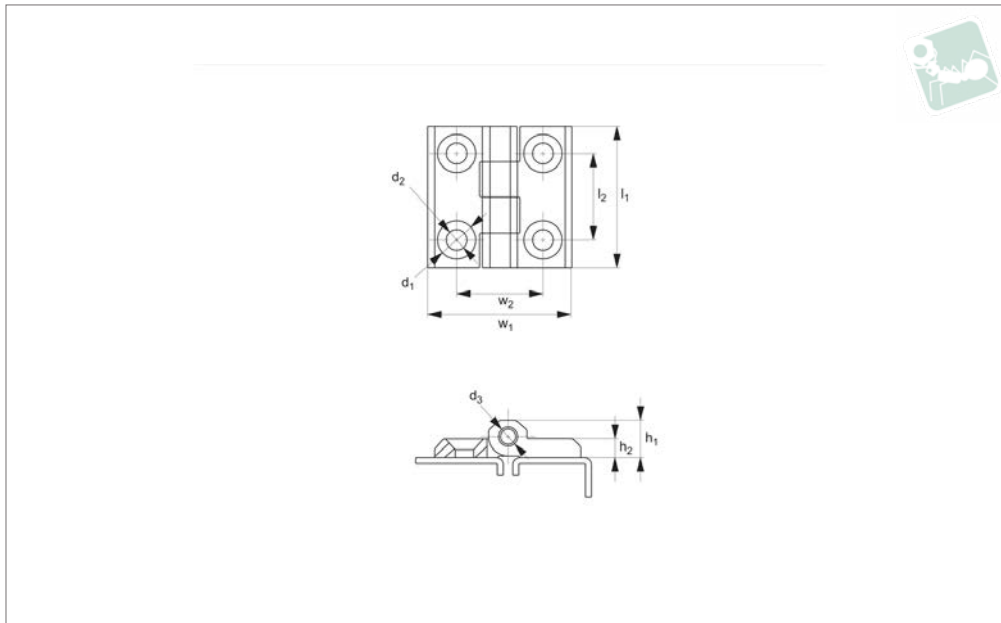

### HH0020

STAYS & HINGES

#### Material

Stainless steel, AISI 304.

electrical panels and covers.

Opening angle 180°.

#### Technical Notes

For plain/flush mounted doors, as well as

Order No.	Size	$h_1$	$h_2$	$l_1$	$l_2$	$w_1$	$w_2$	$d_1$	$d_2$	$d_3$	90° Angled stress kN	Axial load $F_x$ N max.	Axial stress kN	Radial load $F_x$ N max.	Radial stress kN
HH0020.M0050	50 x 50	11,5	6	50	30	50	30	12,5	6,3	7	2,45	1,3	2,10	1,2	3,5
HH0020.M0060	60 x 60	15,0	8	60	36	60	36	12,5	8,4	8	4,40	1,8	3,20	1,5	6,0



**HH0100**

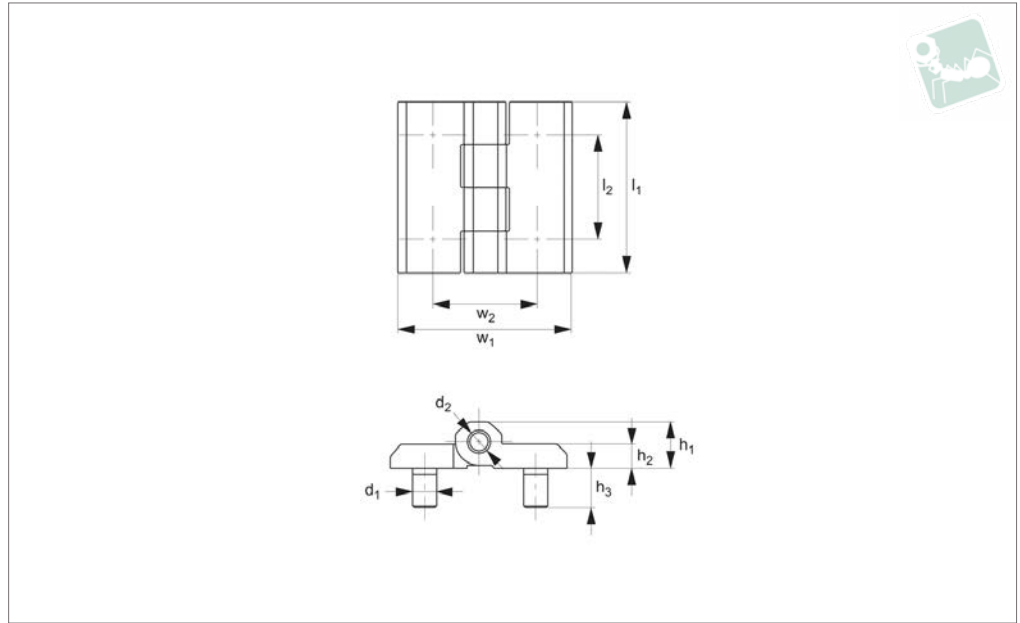

**Material**

Body: die cast zinc, black powder coated.  
Pin: steel, nickel plated.

**Technical Notes**

For plain/flush mounted doors, as well as electrical panels and covers.

Opening angle 180°.

Order No.	Finish	Size	h <sub>1</sub>	h <sub>2</sub>	h <sub>3</sub>	l <sub>1</sub>	l <sub>2</sub>	w <sub>1</sub>	w <sub>2</sub>	d <sub>1</sub>	d <sub>2</sub>	90° Angled stress	Axial load F <sub>x</sub> N max.	Axial stress kN	Radial load F <sub>x</sub> N max.	Radial stress kN
HH0100.M0040	Black Coated	40 x 40	9,0	5	10,0	40	25	40	25	M 5	4	1,85	1,2	0,9	1,0	1,7
HH0100.M0050	Black Coated	50 x 50	11,5	6	12,5	50	30	50	30	M 6	6	2,0	1,3	2,05	1,2	3,55
HH0100.M0057	Black Coated	50 x 70	11,5	6	12,5	50	30	76	56	M 6	6	2,00	1,2	1,5	11,2	3,00
HH0100.M0060	Black Coated	60 x 60	15,0	8	16,5	60	36	60	36	M 6	8	2,55	1,8	3,05	1,5	4,05
HH0100.M0612	Black Coated	60 x 120	15,0	8	16,5	60	36	120	88	M 8	8	1,5	1,2	1,5	1,12	4,5

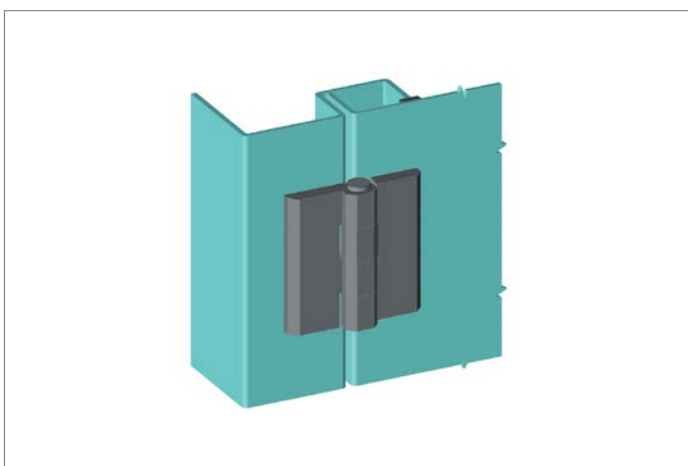



# Surface Mount - Leaf Hinges

intergrated stud mount - zinc

## Stays & Hinges

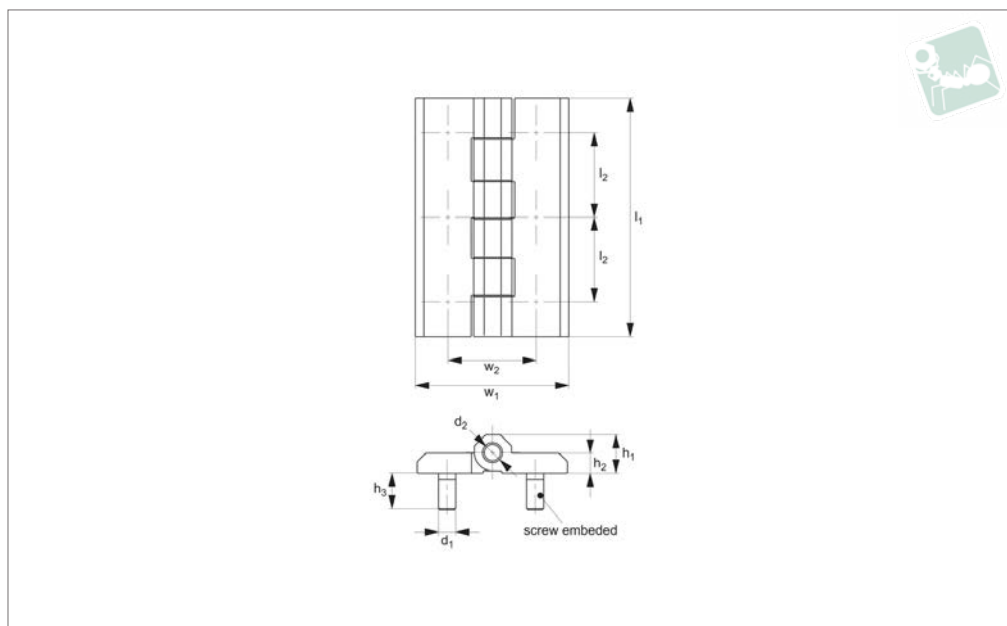

**HH0102**

STAYS & HINGES

### Material

Hinge: die cast zinc, black powder coated.  
Pin: nickel-plated steel.

### Technical Notes

Opening angel 180°.

Order No.	Type	$h_1$	$h_2$	$h_3$	$l_1$	$l_2$	$w_1$	$w_2$	$F_x$ kN	$F_y$ kN	$d_1$	$d_2$
HH0102.M0010	Left	15	8	14.5	90	32	60	36	1.12	1.2	M 8	8
HH0102.M0020	Right	15	8	14.5	90	32	60	36	1.12	1.2	M 8	8



**HH0410**

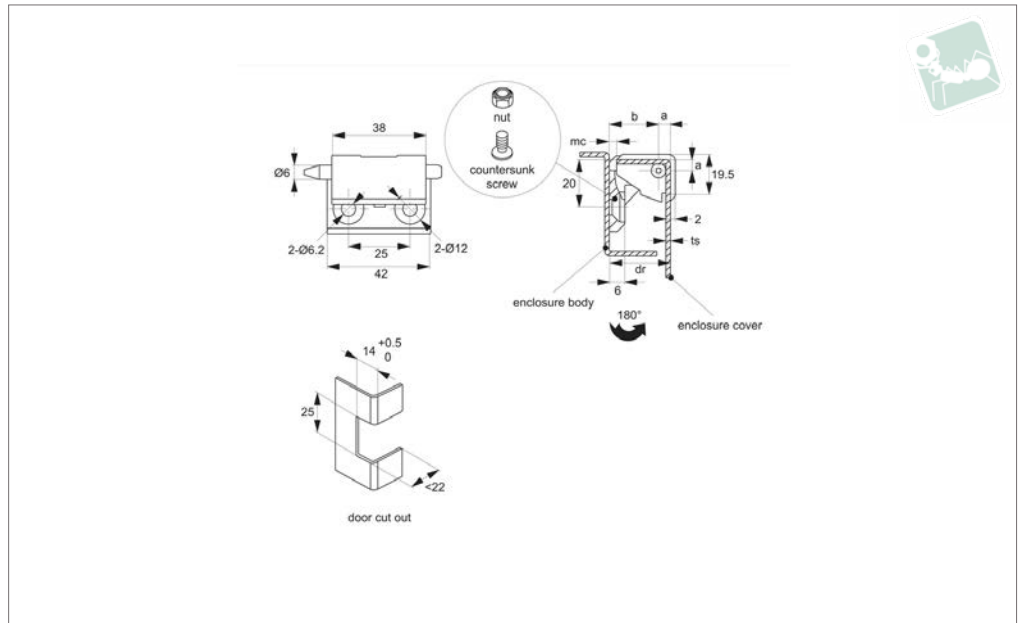

**Material**

Hinge: die cast zinc, black powder coated.  
Pin: steel, nickel-plated.

**Technical Notes**

For sheet metal and machine enclosures with a 24 to 26mm door return up to 3mm

thick. For installation dimension see cut out detail.

Mounting via M6 screws.  
Universal left or right hand opening doors.  
Max. opening angle 180°.

**Important Notes**

dr= Maximum door return suitable for use with hinge.

mc= Minimum clearance advised between enclosure cover and body to ensure smooth, full opening of enclosure cover.

Order No.	Finish	Door return	a	b	F <sub>x</sub> N	F <sub>y</sub> N	mc min.	ts panel thickness
HH0410.M0001	Black coated	24.1	4.6	20	1050	980	3	1.5
HH0410.M0002	Black coated	25.1	5.1	20	1050	980	3	2.0
HH0410.M0003	Black coated	26.1	6.1	20	1050	980	3	3.0

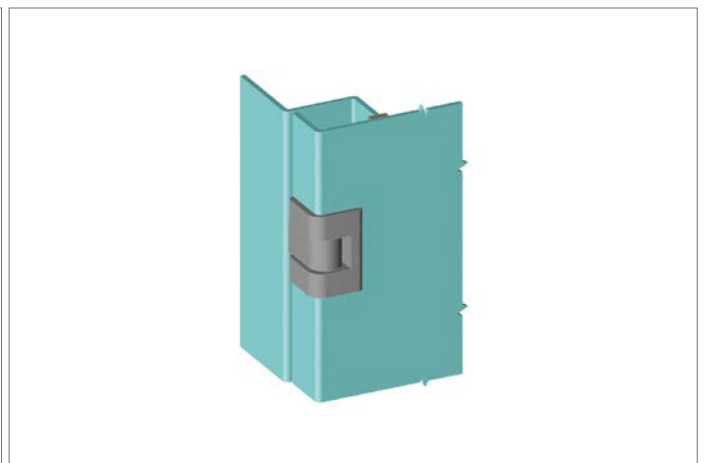
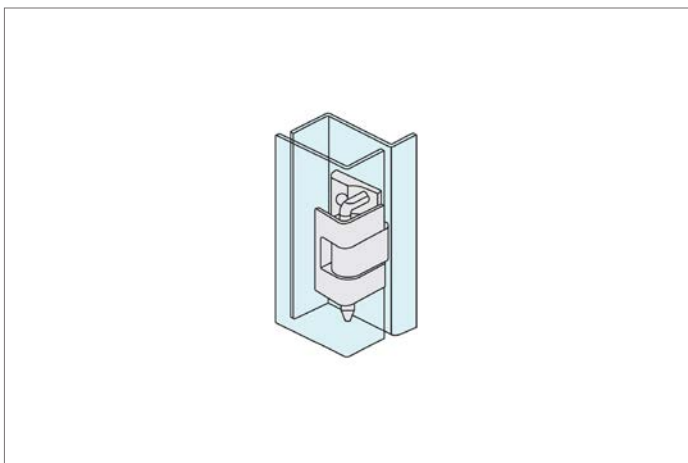



# Corner Hinge - 17mm Door Return cut out and countersunk screw - zinc

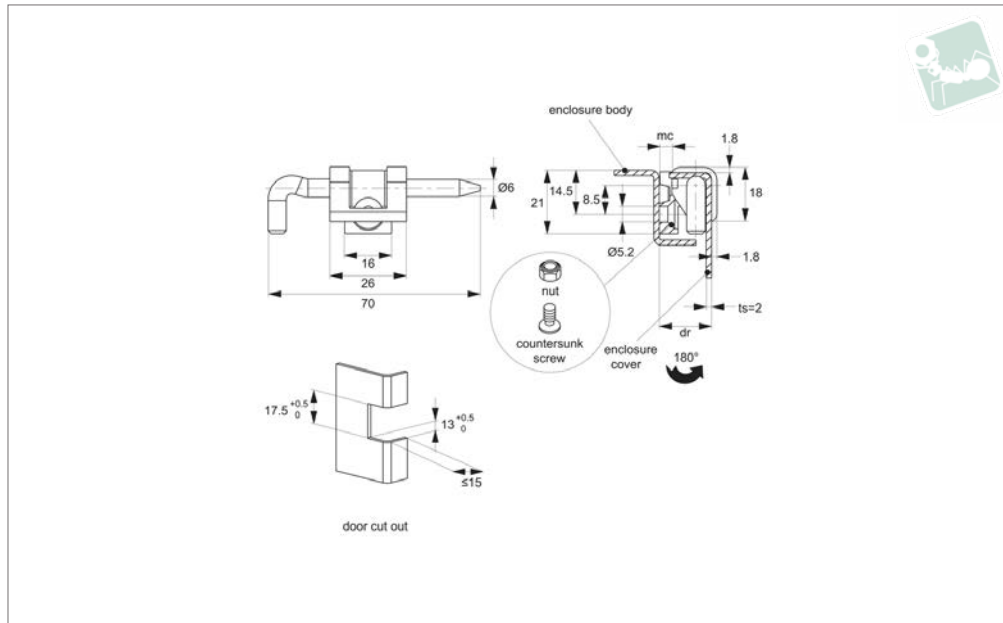

### HH0420

STAYS & HINGES

#### Material

Hinge: die cast zinc, black powder coated.  
Pin: stainless steel AISI 304.

#### Technical Notes

For sheet metal and machine enclosures with a 17mm door return, upto 2mm thick.  
For installation dimension see cut out

#### detail.

Universal left or right hand opening doors.  
Max. opening angle 180°.

#### Tips

Mounting via M5 countersunk screws (not supplied).

#### Important Notes

dr= Maximum door return suitable for use with hinge.

mc= Minimum clearance advised between enclosure cover and body to ensure smooth, full opening of enclosure cover.

Order No.	Finish	Door return	F <sub>x</sub> N	F <sub>y</sub> N	mc min.	ts panel thickness
HH0420.M0010	Black coated	17	405	805	2	2.0

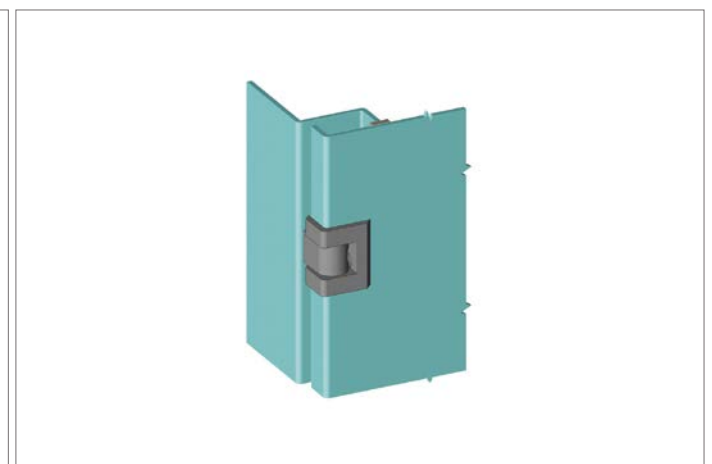
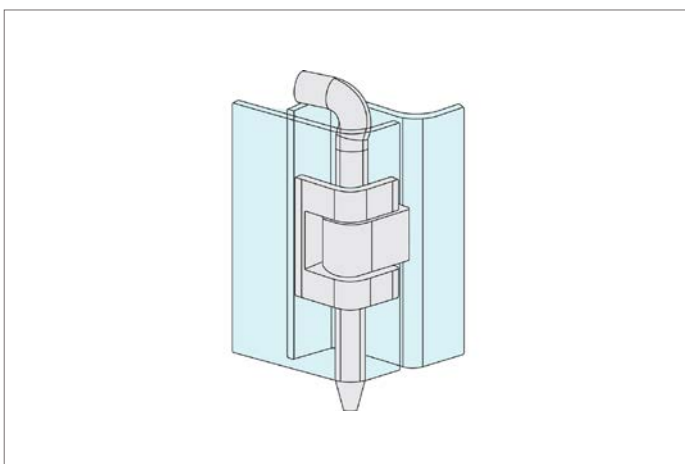



HH0700

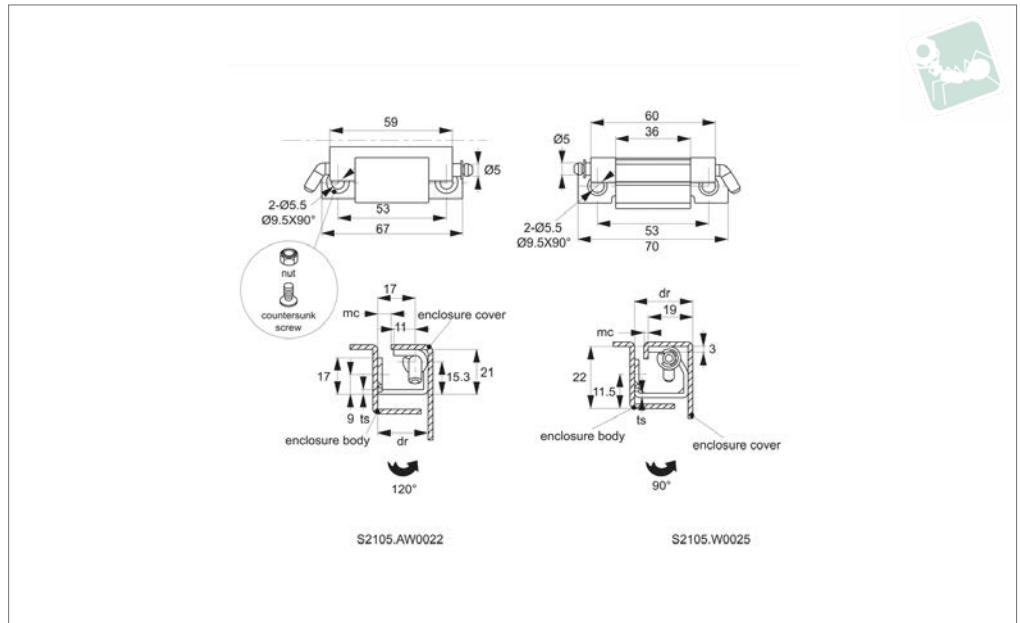

Material

Body & hinge: steel, white zinc plated.

Technical Notes

Suited to sheet metal and machine enclosures with 22-25mm door return. Main body

mounted via two M5 screws. Hinge plate either welded or screwed to enclosure body.

Removable hinge pin enables easy installation and is held in place via circlip. Max. opening angle 120° or 90°.

Important Notes

dr= Maximum door return suitable for use with hinge.

mc= Minimum clearance advised between enclosure cover and body to ensure smooth, full opening of enclosure cover.

Order No.	Door return	Size	F <sub>x</sub> N	F <sub>y</sub> N	mc min.	ts thickness
HH0700.M0022	25	59 x 21 x 22	120	310	4.5	2.5
HH0700.M0025	22	60 x 22 x 25	120	310	4.0	2.5





# Concealed Pivot Hinges - Lift Off

23mm door return - weld and countersunk screw

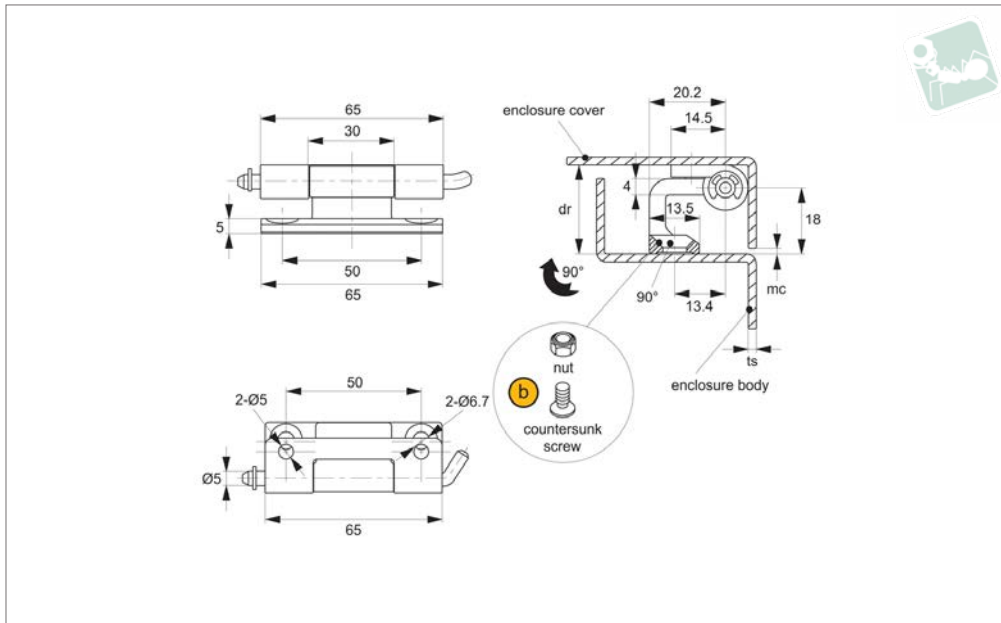

### HH0710

STAYS & HINGES

#### Material

Hinge & pin: steel, white zinc plated.

#### Technical Notes

Suited to sheet metal and machine enclosures with 23mm door return. When the gap between the door and frame is 2mm, opening angle is 90°.

Main body mounted via M6 screws, hinge plate either welded or screwed to enclosure with M5 screws. Removable hinge pin enables easy installation and is held in place via circlip. Opening angle 180°.

#### Important Notes

dr= Maximum door return suitable for use with hinge.

mc= Minimum clearance advised between enclosure cover and body to ensure smooth, full opening of enclosure cover.

Order No.	Door return	Size	F <sub>x</sub> N	F <sub>y</sub> N	mc min.	ts panel thickness
HH0710.M0024	23.8	65 x 23 x 20,2	900	700	2	2

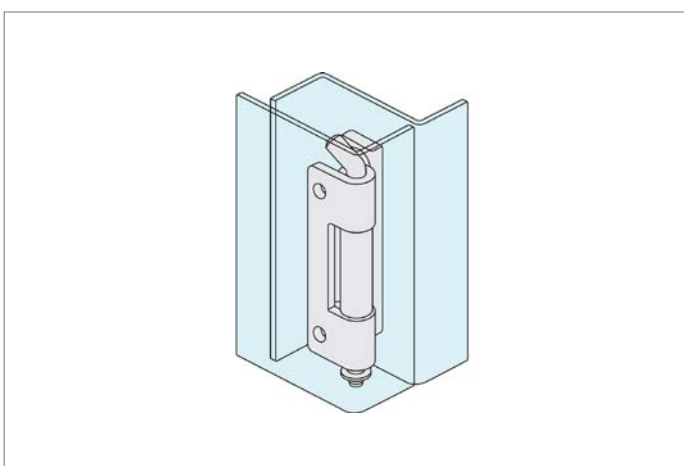



HH0720

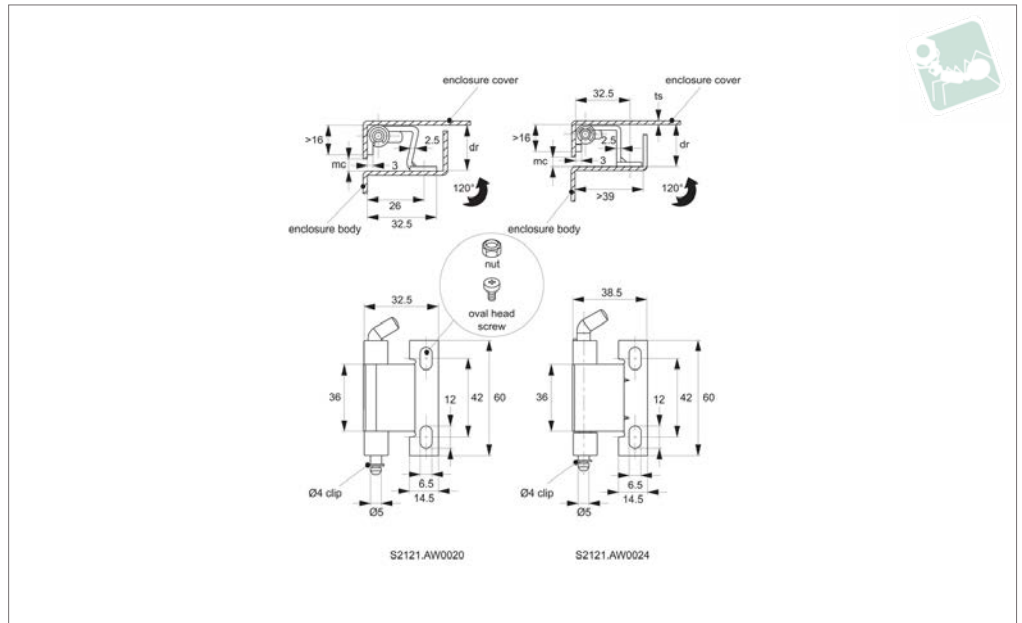

**Material**

Hinge & pin: steel, white zinc plated.

**Technical Notes**

Suited to sheet metal and machine enclosures with door return of 20-24mm. Main body mounted via two M6 screws, hinge

plate welded to frame.

Removable hinge pin enables easy installation, and is held in place via circlip. Max. opening angle 120°.

**Important Notes**

dr= Maximum door return suitable for use

with hinge.

mc= Minimum clearance advised between enclosure cover and body to ensure smooth, full opening of enclosure cover.

Order No.	Door return	Size	F <sub>x</sub> N	F <sub>y</sub> N	mc min.	ts panel thickness
HH0720.M0020	20.0	60,0 x 32,5 x 20,0	350	778	3	2.0
HH0720.M0024	24.5	60,0 x 38,5 x 24,5	350	778	3	2.0

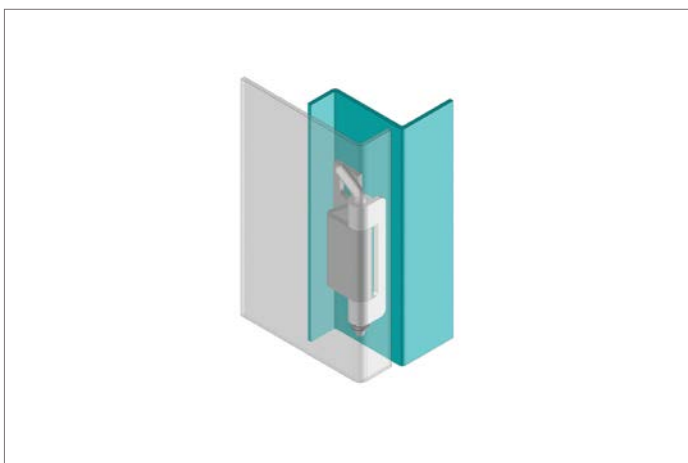





# Concealed Pivot Hinges - Lift Off

20 & 24mm door return - weld and oval head screw

## Stays & Hinges

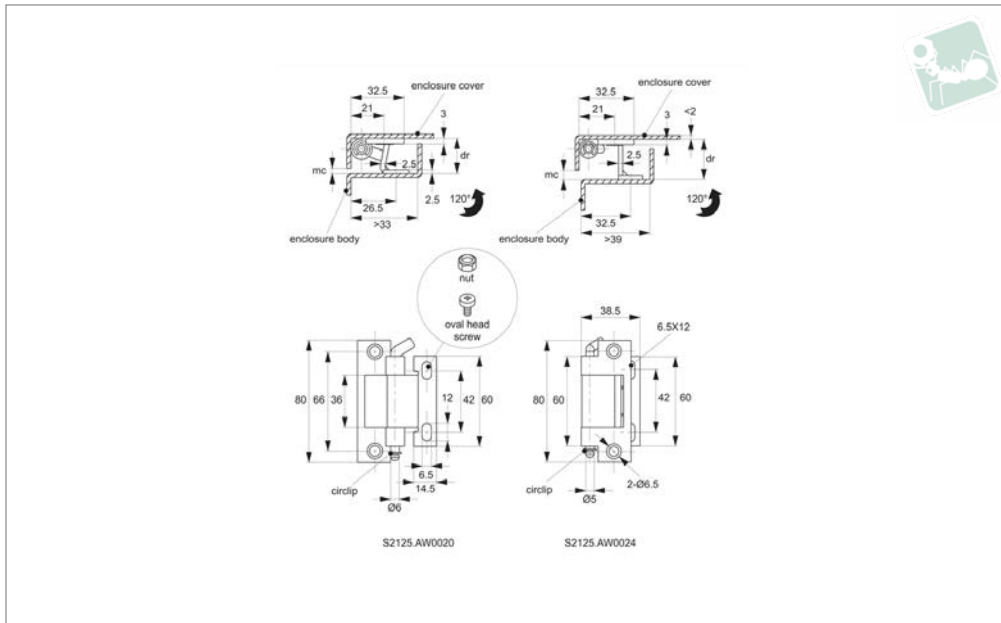

**HH0730**

STAYS & HINGES

**Material**

Hinge & pin: steel, white zinc plated.

**Technical Notes**

Suited to sheet metal and machine enclosures with 20-24mm door return. Main body mounted via two M6 screws, hinge plate

welded to frame.

Removable hinge pin enables easy installation, and is held in place via circlip. Max. opening angle 120°.

**Important Notes**

dr= Maximum door return suitable for use

with hinge.

mc= Minimum clearance advised between enclosure cover and body to ensure smooth, full opening of enclosure cover.

Order No.	Door return	Size	F <sub>x</sub> N	F <sub>y</sub> N	mc min.	ts panel thickness
HH0730.M0020	20.0	60,0 x 33,0 x 20,0	310	480	3.0	2.0
HH0730.M0024	24.5	60,0 x 39,0 x 24,5	310	480	2.5	2.0

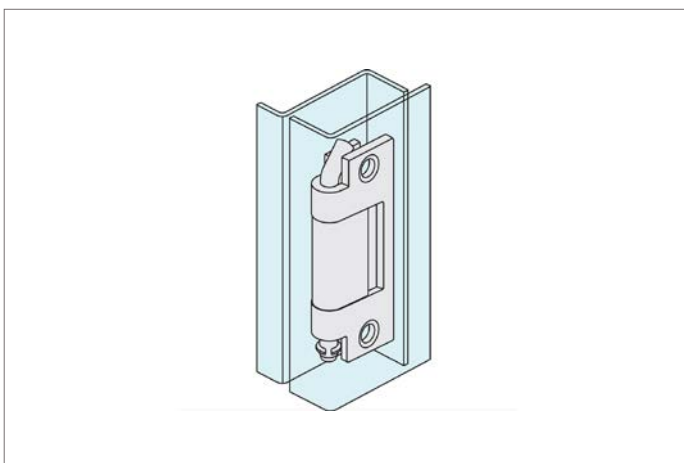



**HH0900**

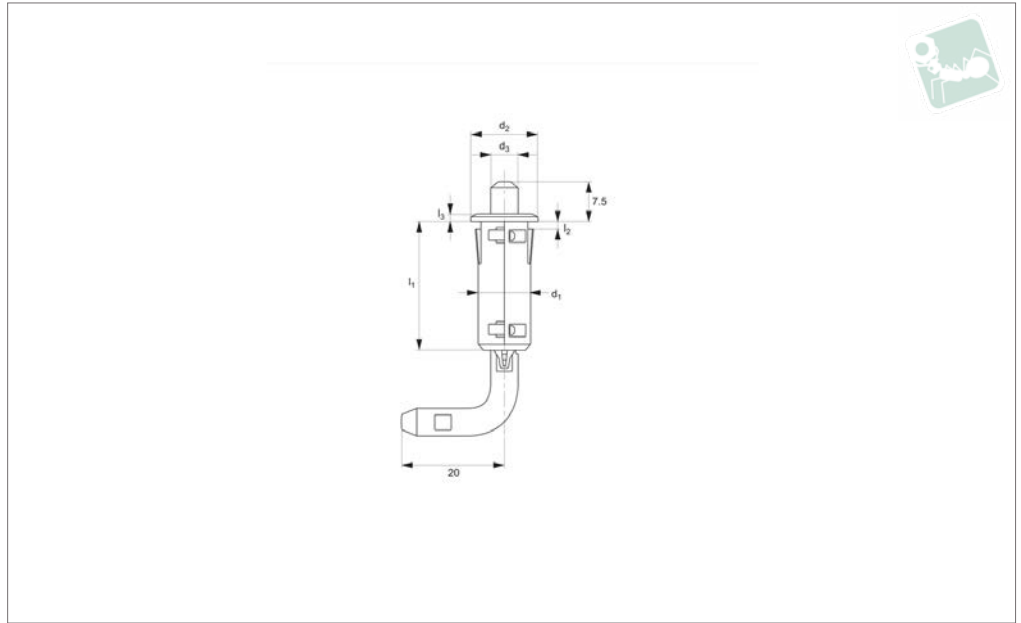

**Material**

Body: polyamide, black PA 6 GRF30.  
Pin: stainless steel.  
Latch: die cast zinc, white zinc plated.

ery covers. Clip fix for easy assembly.  
Pull back pin lever, hinge pin is retracted.  
Release pin lever and hinge pin springs  
back. Opening angle 180°.

easy assembly and disassembly of panel/  
door, ideal for maintenance covers.  
Max. opening angle 110°.

**Technical Notes**

For sheet metal doors, cabinets and machi-

**Tips**

Spring loaded feature of hinge enables

Order No.	$l_1$	$d_1$	$d_2$	$d_3$	$l_2$	$l_3$
HH0900.M0005	24.5	10	13	5	7.5	1.5

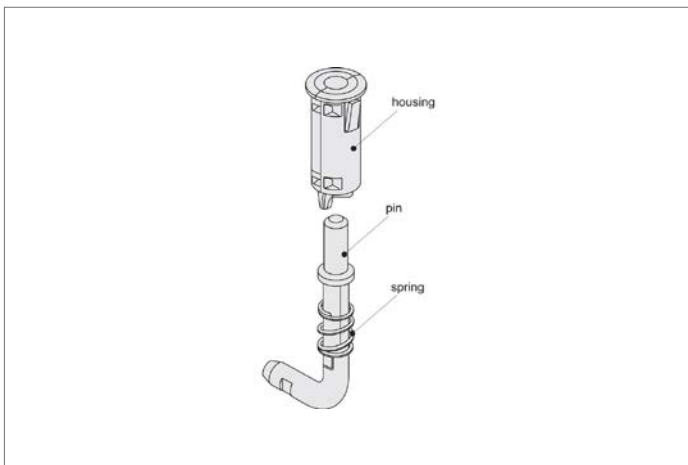



# Lift-Off Hinges - Off-Set

screw mount - stainless steel

## Stays & Hinges

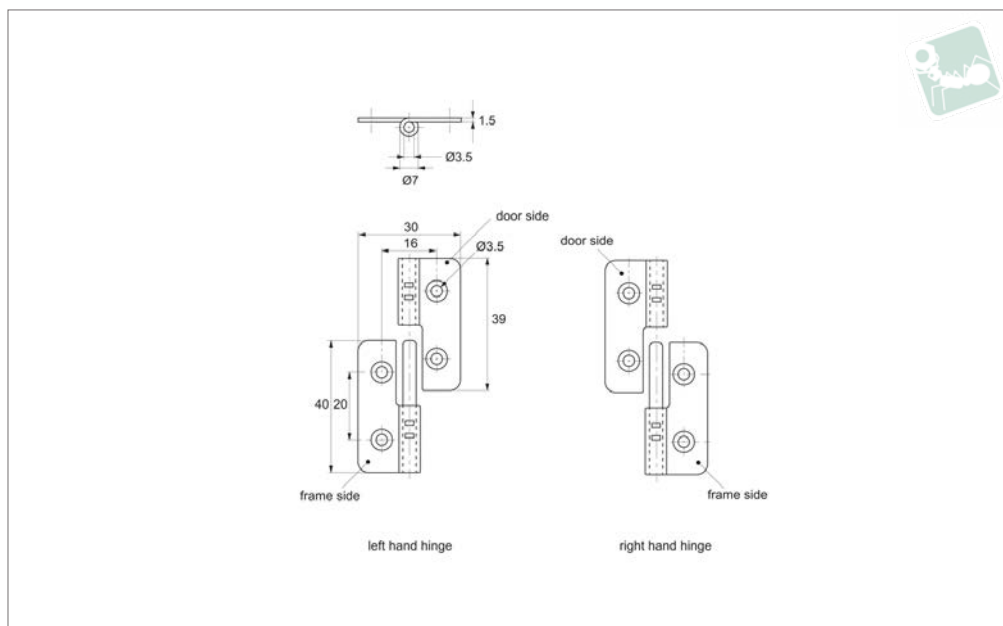

### HH1200

STAYS & HINGES

#### Material

Stainless steel, AISI 304, polished finish.

#### Important Notes

Product stamped with an „L“ does not

mean it is a left hand hinge - it fixes to the right hand part of the frame.

Product stamped with an „R“ does not mean it is a right hand hinge - it fixes to

the left hand side of the frame.

Order No.	t	Type	Weight g
HH1200.M0010	1.5	Right	21
HH1200.M0110	1.5	Left	21



HH1210

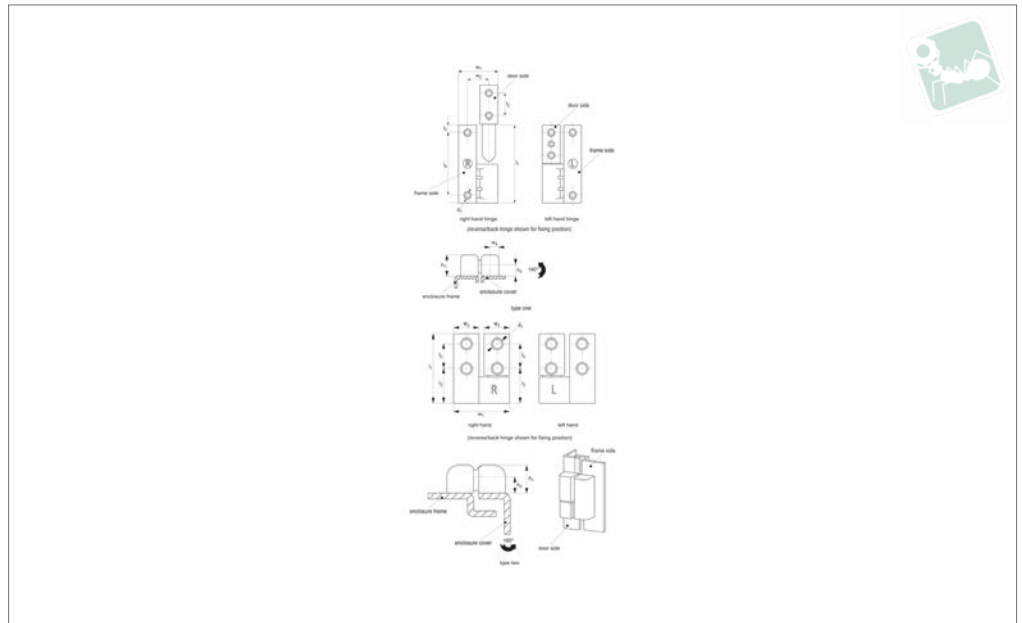

Material

**Type one:** Body: die cast zinc, black powder coated.

Bushing: polyamide.

**Type two:** Body: die cast zinc, black powder

coated.

Natural unfinished available on request, subject to minimum order quantity.

Technical Notes

Lift off hinge for plain/flush mounted doors. Concealed mounting screws prevent external access to the hinge. Opening angle 180°.

Order No.	Type	Hand	$l_1$	$w_1$	$d_1$	$h_1$	$h_2$	$l_2$	$l_3$	$l_4$	$l_5$	$w_2$	$w_3$	$F_x$ N
HH1210.M0025	One	Right	64.0	32.5	M 5	17.5	10.0	19	-	51	6.5	17.5	-	490
HH1210.M0125	One	Left	64.0	32.5	M 5	17.5	10.0	19	-	51	6.5	17.5	-	490
HH1210.M0064	Two	Right	25.5	20.5	M 4	10.0	5.5	9	13	-	-	-	9.4	270
HH1210.M0164	Two	Left	25.5	20.5	M 4	10.0	5.5	9	13	-	-	-	9.4	270

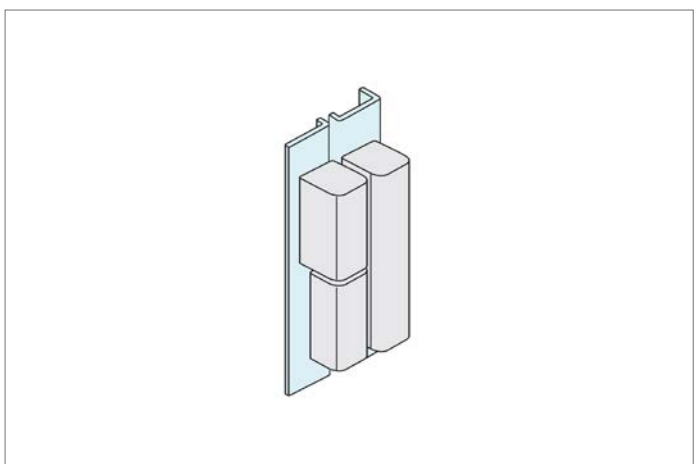
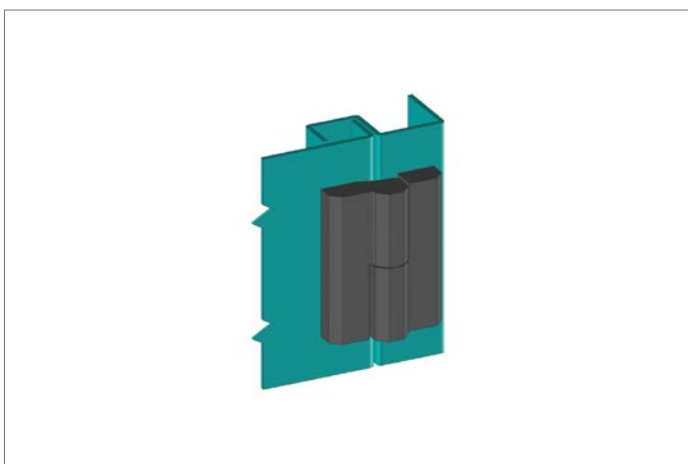

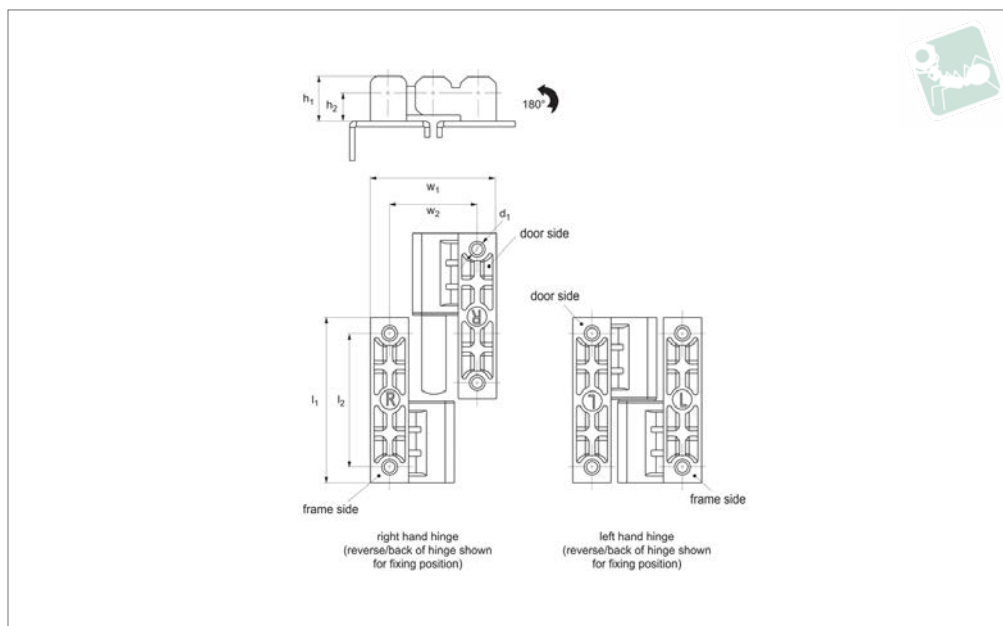

## HH1215

STAYS & HINGES

### Material

Hinge: die cast zinc.  
Bushing: polyamide.

### Technical Notes

Opening angle 180°.

Order No.	Type	$l_1$	$w_1$	$d_1$	$h_1$	$h_2$	$l_2$	$w_2$	$F_x$ N	$F_y$ N
HH1215.M0064	Right	64	50	M5	17.5	10	51	35	3300	880
HH1215.M0164	Left	64	50	M5	17.5	10	51	35	3300	880



**HH1220**

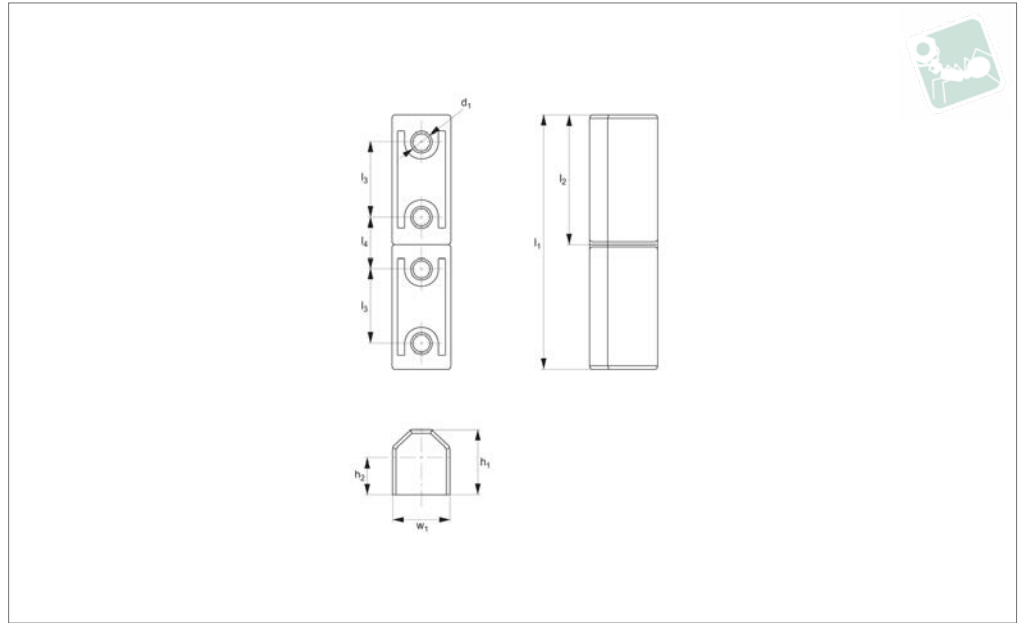

**Material**

Body: die cast zinc, chrome plated or black powder coated.  
Bushing: polyamide.

**Technical Notes**

Universal left or right hand opening doors.  
For external mounting on cabinets, surface mounted doors, sheet metal doors etc.

Mounting via concealed 4xM 5 screws.  
Opening angle 180°.

Order No.	Finish	$l_1$	$w_1$	$d_1$	$h_1$	$h_2$	$l_2$	$l_3$	$l_4$	$F_x$ N	$F_y$ N
HH1220.M0010	Chrome	64	15	M 5	17	10	32	19	13	600	1500
HH1220.M0020	Black Coated	64	15	M 5	17	10	32	19	13	600	1500



# Corner Hinge - 19-24mm Door Return cut out and locking screw - zinc

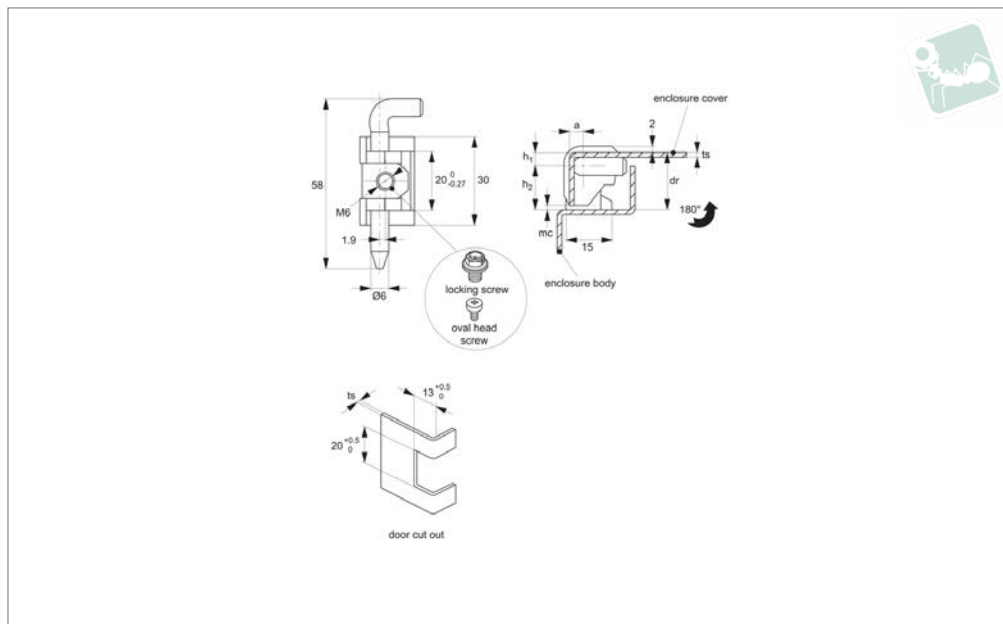

### HH0400

#### Material

Hinge: die cast zinc, black powder coated.  
Pin: steel, nickel plated.

#### Technical Notes

Opening angle 180°. For sheet metal and machine enclosures with 19-24mm door

return and panel thickness 1,5 to 2,0mm.  
See installation cut out for details.

#### Tips

Mounting via M6 locking screw locking screw (not supplied).

#### Important Notes

dr= Maximum door return suitable for use with hinge.

mc= Minimum clearance advised between enclosure cover and body to ensure smooth, full opening of enclosure cover.

Order No.	Finish	Door return	$h_1$	$h_2$	$F_x$ N	$F_y$ N	mc min.	ts panel thickness
HH0400.M0015	Black Coated	19.6	4.6	15	940	720	2	1.5
HH0400.M0017	Black Coated	21.6	4.6	17	940	720	2	1.5
HH0400.M0019	Black Coated	23.6	4.6	19	940	720	2	1.5
HH0400.M0025	Black Coated	21.1	5.1	15	425	225	2	2.0
HH0400.M0027	Black Coated	22.1	5.1	17	425	225	2	2.0
HH0400.M0029	Black Coated	24.1	5.1	19	425	225	2	2.0

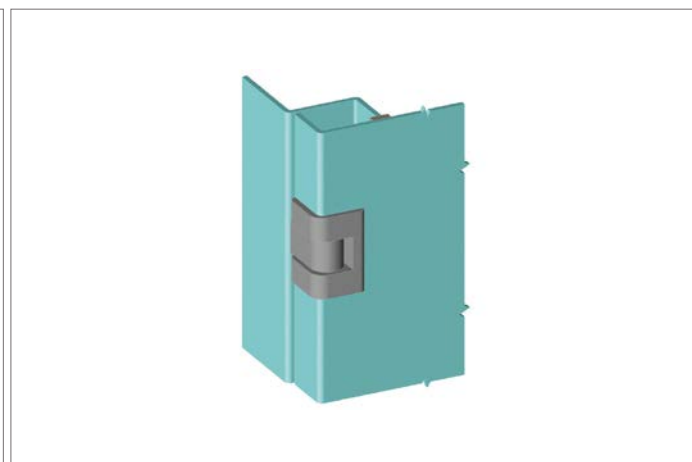
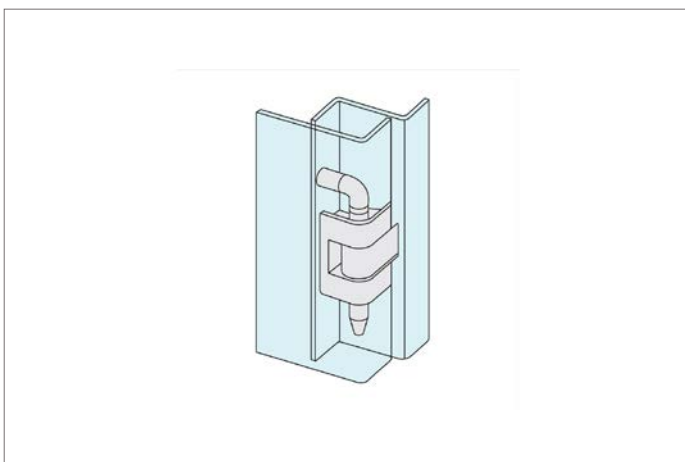



HH0750

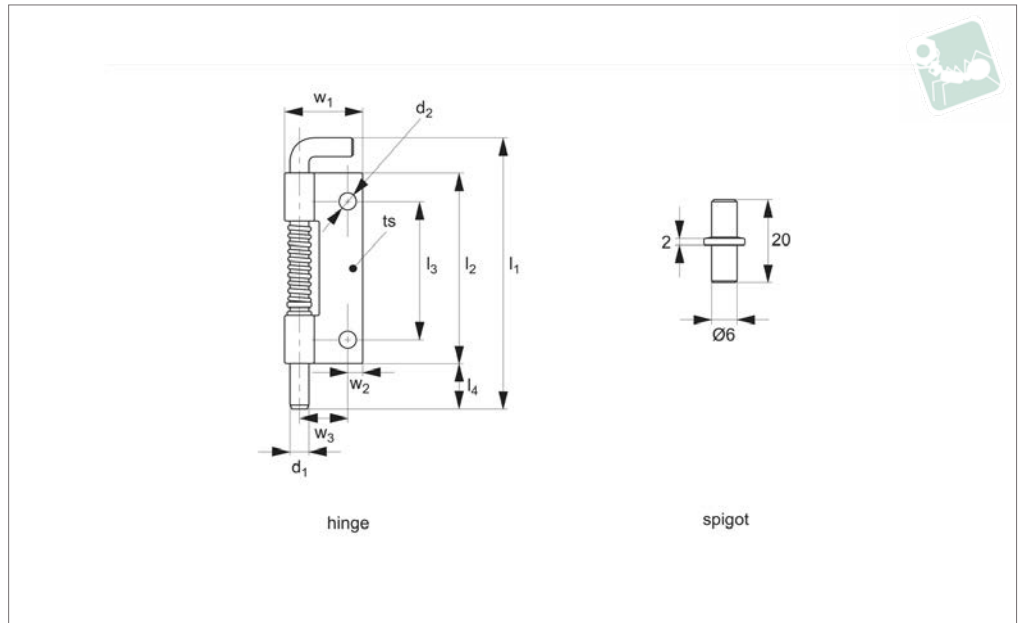

**Material**

Body: steel, zinc plated.

**Technical Notes**

For sheet metal doors, cabinets and machinery covers. Spring body can be either welded, or screw mounted.

Pull back pin lever, hinge pin is retracted.  
Release pin lever and hinge pin springs back.  
Max. opening angle 110°.

**Tips**

Spring loaded feature of hinge enables

easy assembly and disassembly of panel/door, ideal for maintenance covers.  
Typical assembly utilises spring loaded hinge at top of door and corresponding hinge spigot at foot of door.

Order No.	Hand	$l_1$	$w_1$	$d_1$	$d_2$	$F_x$ N	$F_y$ N	$l_2$	$l_3$	$l_4$	$w_2$	$w_3$	ts
HH0750.M0032	Left	52	16.5	4	3.2	150	200	32.0	19	10	5	8.5	2
HH0750.M0132	Right	52	16.5	4	3.2	100	130	32.0	19	10	5	8.5	2
HH0750.M0063	Left	89	26.5	6	5.5	150	200	62.5	45	15	6	15.2	2
HH0750.M0163	Right	89	26.5	6	5.5	150	200	62.5	45	15	6	15.2	2

