

B0504.B0

BRASS

Material
Brass.

Technical Notes
DIN 934. Fine pitch threads.
For coarse thread full nuts see P0301.

Order No.	d ₁	h ₁ min.	A/F	Material
B0504.080100B000	M8x1	6.14	13	Brass
B0504.100100B000	M10x1	7.64	17	Brass
B0504.300150B000	M30x1,5	22.7	46	Brass

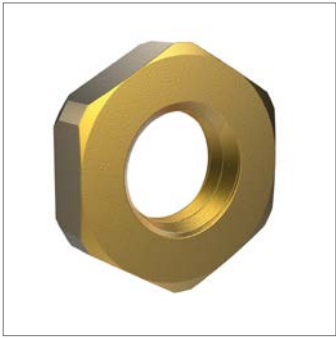

B0510.B0

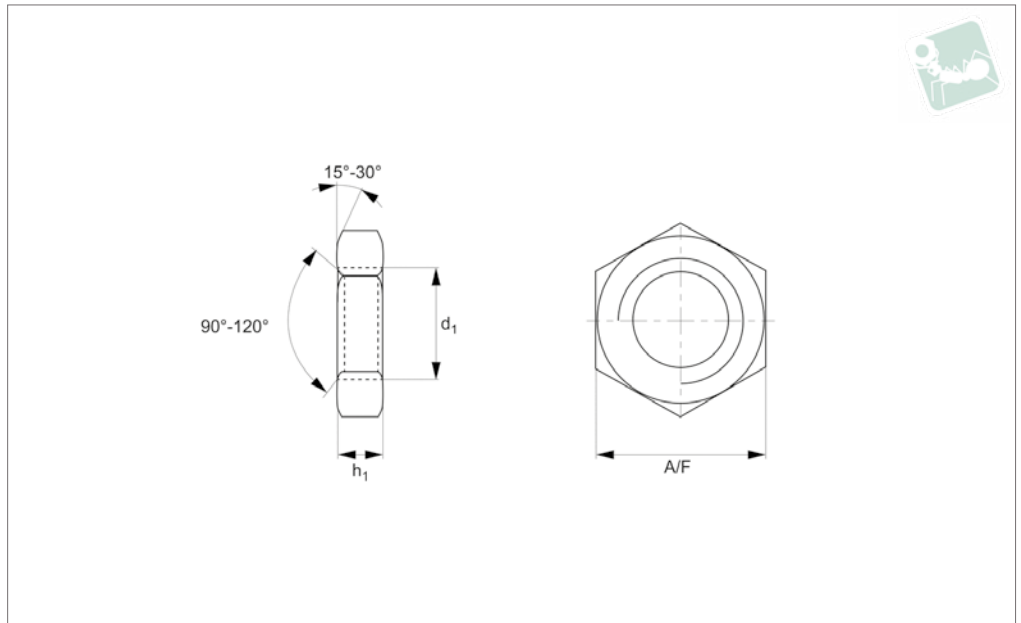

BRASS

Material

Brass, Cu3 (CuZn39Pb3).

Technical Notes

To DIN 439. Fine pitch threads.

Order No.	Thread d ₁	h ₁	A/F	Material	Finish
B0510.080-100	M 8x1,0	3.7	13	Brass	unfinished
B0510.100-100	M10x1,0	4.7	17	Brass	unfinished
B0510.120-150	M12x1,5	5.7	19	Brass	unfinished
B0510.140-150	M14x1,5	6.42	22	Brass	unfinished
B0510.160-150	M16x1,5	7.42	24	Brass	unfinished
B0510.180-150	M18x1,5	8.42	27	Brass	unfinished
B0510.200-150	M20x1,5	9.1	30	Brass	unfinished
B0510.220-150	M22x1,5	9.9	34	Brass	unfinished
B0510.240-150	M24x1,5	10.9	36	Brass	unfinished
B0510.270-150	M27x1,5	12.4	41	Brass	unfinished
B0510.300-150	M30x1,5	13.9	46	Brass	unfinished



Hexagon Cap Nuts

Low Pattern, DIN 917

Brass

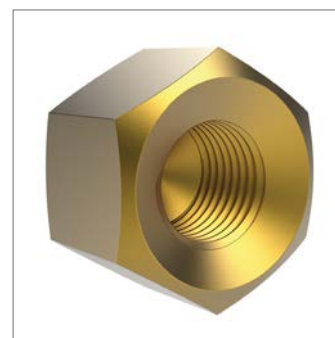
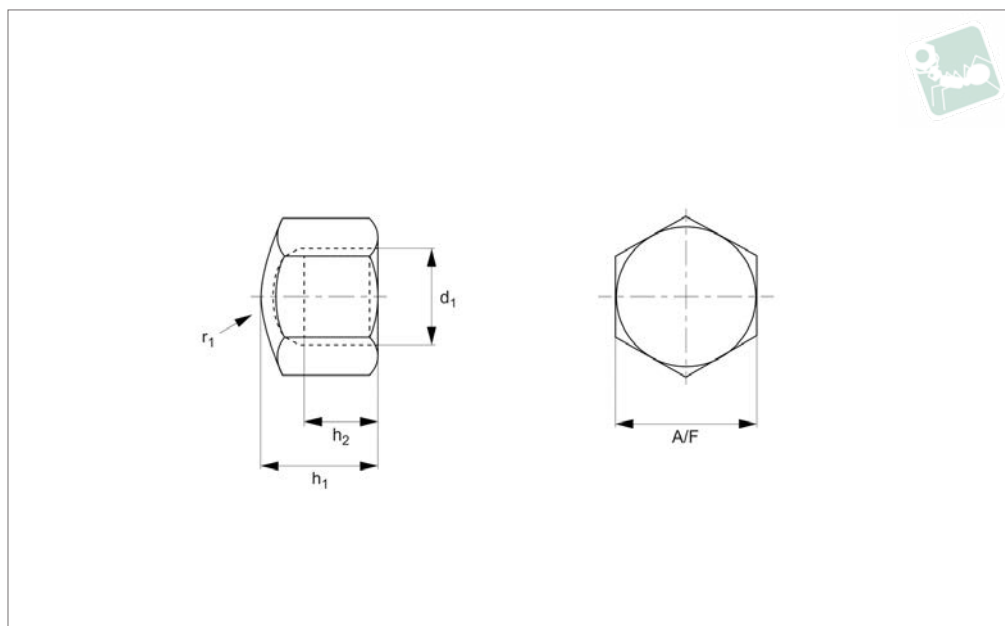

B0513.B0

BRASS

Material

Brass, Cu3 (CuZn39Pb3).

Technical Notes

To DIN 917.

Order No.	Thread d_1	h_1	h_2 min.	A/F	r_1	Material	Finish
B0513.030	M 3	5.0	3.0	5.5	-	Brass	unfinished
B0513.040	M 4	5.5	4.4	7.0	8	Brass	unfinished
B0513.050	M 5	7.0	5.2	8.0	10	Brass	unfinished
B0513.060	M 6	9.0	7.0	10.0	12	Brass	unfinished
B0513.080	M 8	12.0	9.5	13.0	15	Brass	unfinished
B0513.100	M10	14.0	11.0	17.0	20	Brass	unfinished
B0513.120	M12	16.0	13.5	19.0	25	Brass	unfinished
B0513.140	M14	18.0	15.0	22.0	28	Brass	unfinished
B0513.160	M16	20.0	17.0	24.0	30	Brass	unfinished
B0513.200	M20	25.0	21.0	30.0	35	Brass	unfinished



B0525.B0

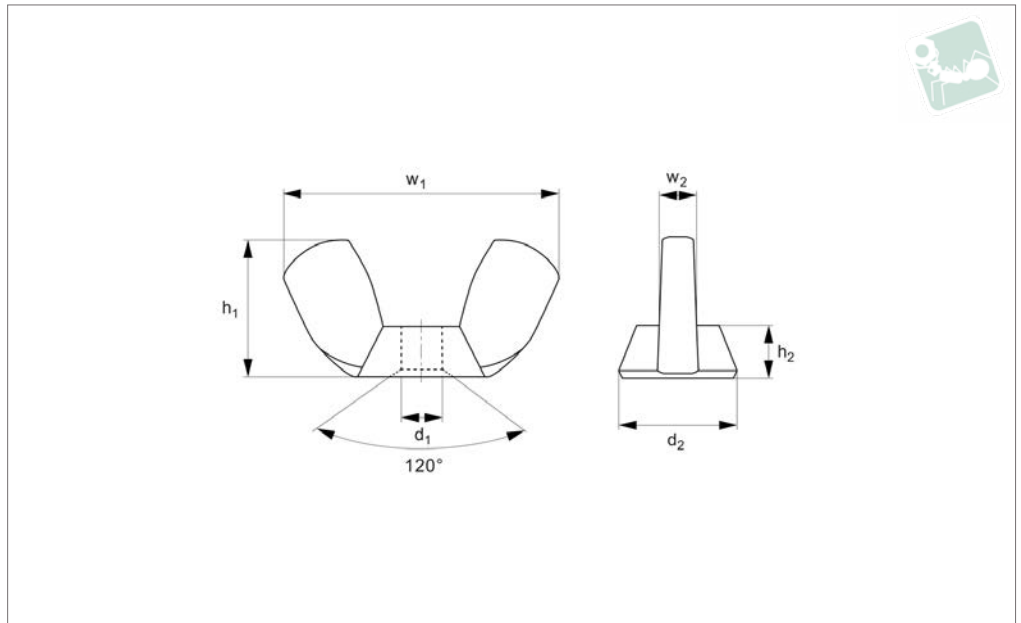

Material

Brass, Cu3 (Cuzn39Pb3).

Technical Notes

DIN 315

Order No.	d ₁	d ₂	h ₁	h ₂	w ₁	w ₂	Material	Finish
B0525.030	M 3	6.8	8.8	15.3	15.3	1.2	Brass	Unfinished
B0525.040	M 4	8.0	8.8	17.6	17.6	1.6	Brass	Unfinished
B0525.050	M 5	10.3	10.5	22.5	22.5	2.1	Brass	Unfinished
B0525.060	M 6	12.7	12.9	27.8	27.8	2.5	Brass	Unfinished
B0525.080	M 8	13.8	14.8	30.3	30.3	2.8	Brass	Unfinished
B0525.100	M10	16.5	17.3	36.2	36.2	3.3	Brass	Unfinished
B0525.120	M12	22.5	22.3	49.4	49.4	4.5	Brass	Unfinished
B0525.160	M16	26.6	30.8	58.3	58.3	5.5	Brass	Unfinished



Wing Screw male thread

Brass

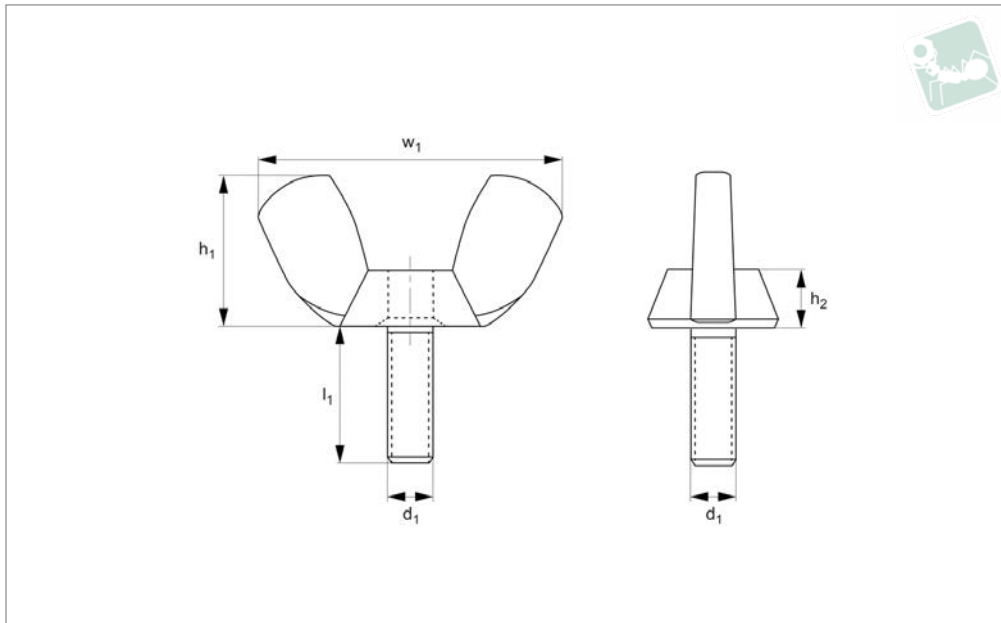

B0528.B0

BRASS

Material

Brass, Cu3 (CuZn39Pb3).

Technical Notes

DIN 316

Order No.	d ₁	h ₁	h ₂	l ₁	w ₁
B0528.050-010	M 5	11.0	4.0	10	24.0
B0528.050-016	M 5	11.0	4.0	16	24.0
B0528.050-020	M 5	11.0	4.0	20	24.0
B0528.050-025	M 5	11.0	4.0	25	24.0
B0528.060-010	M 6	15.0	5.0	10	30.0
B0528.060-016	M 6	15.0	5.0	16	30.0
B0528.060-020	M 6	15.0	5.0	20	30.0
B0528.060-025	M 6	15.0	5.0	25	30.0
B0528.060-030	M 6	15.0	5.0	30	30.0
B0528.060-040	M 6	15.0	5.0	40	30.0
B0528.080-010	M 8	18.0	6.5	10	36.0
B0528.080-016	M 8	18.0	6.5	16	36.0
B0528.080-020	M 8	18.0	6.5	20	36.0
B0528.080-025	M 8	18.0	6.5	25	36.0
B0528.080-030	M 8	18.0	6.5	30	36.0
B0528.080-040	M 8	18.0	6.5	40	36.0
B0528.100-020	M10	23.0	8.0	20	48.0
B0528.100-025	M10	23.0	8.0	25	48.0
B0528.100-030	M10	23.0	8.0	30	48.0
B0528.100-040	M10	23.0	8.0	40	48.0

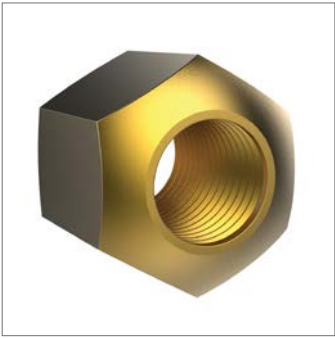

B0531.B0

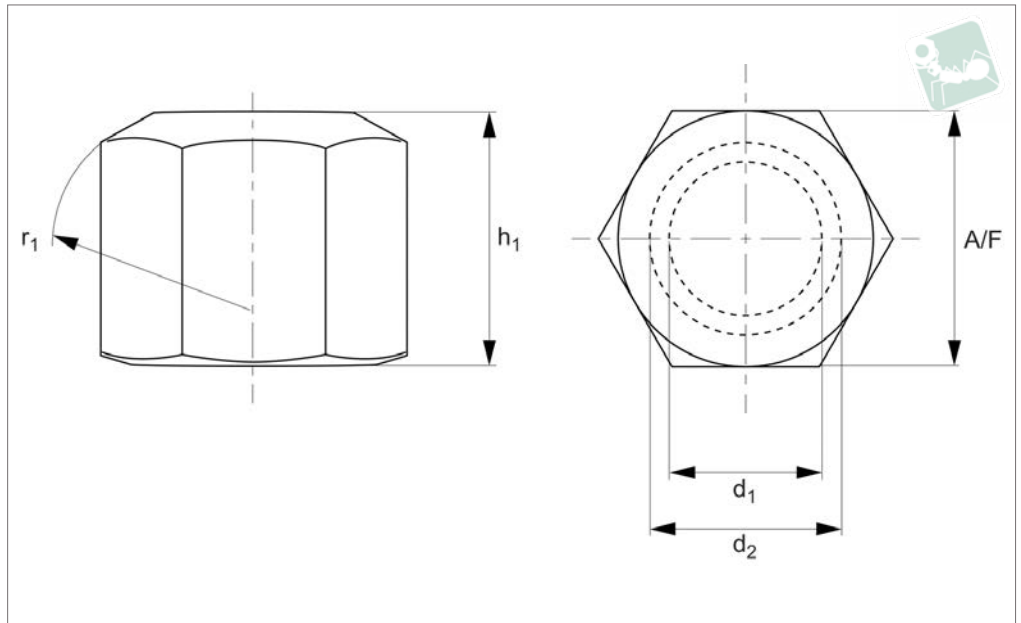

Material
Brass, Cu3 (Cuzn39Pb3).

Technical Notes
DIN 6330 B

Order No.	d ₁	d ₂	h ₁	A/F	r ₁
B0531.060	M 6	7	9	10	9
B0531.080	M 8	9	12	13	11
B0531.100	M10	11.5	15	16	15
B0531.120	M12	14	18	18	17
B0531.160	M16	18	24	24	22
B0531.200	M20	22	30	30	27
B0531.240	M30	32	45	46	41
B0531.360	M36	38	54	55	50



Full Nuts Coarse Thread

Brass

Brass

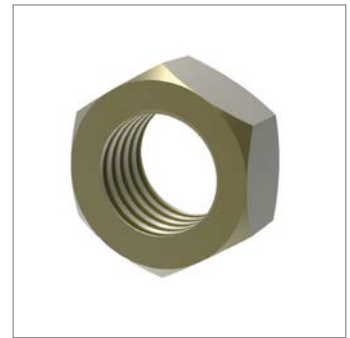
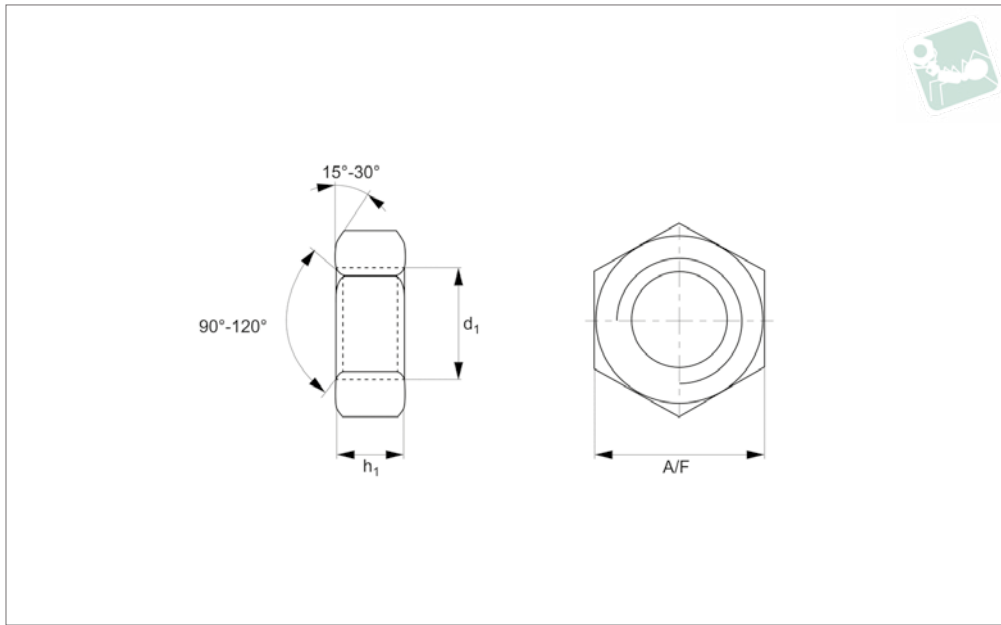

B0501.B0

BRASS

Material

Brass.

threads.

For fine thread full nuts see P0302.

Technical Notes

To DIN 934. Standard metric coarse pitch

Order No.	d_1	h_1 min.	A/F	Material
B0501.040B000	M 4	2.9	7	Brass
B0501.060B000	M 6	4.7	10	Brass
B0501.080B000	M 8	6.14	13	Brass
B0501.100B000	M10	7.64	17	Brass
B0501.200B000	M20	14.9	30	Brass
B0501.300B000	M30	22.7	46	Brass

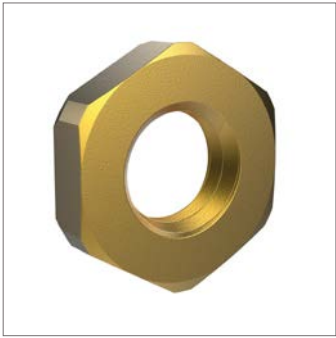

B0507.B0

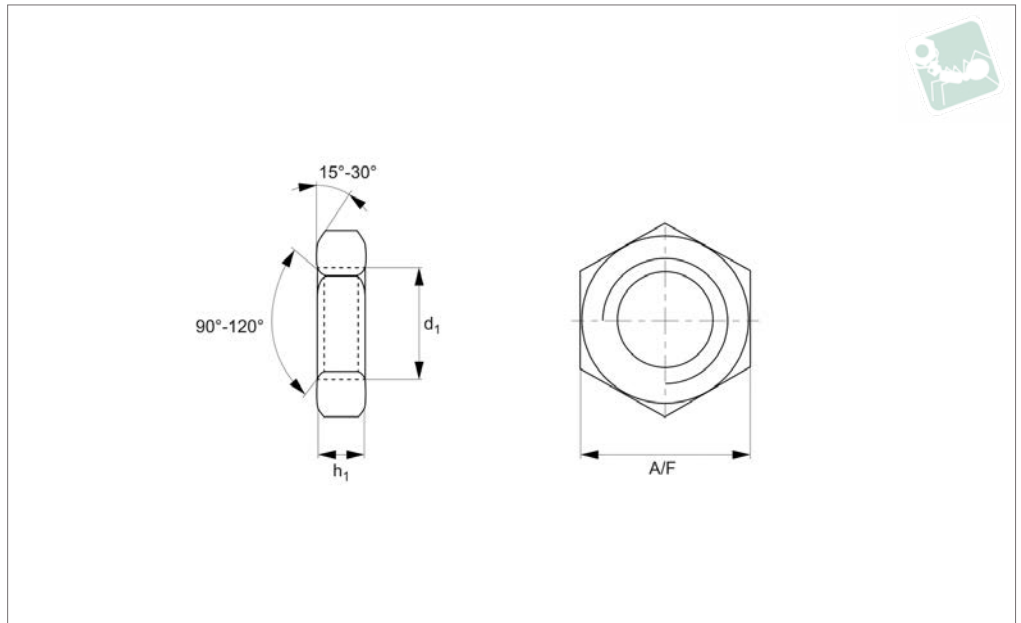

BRASS

Material

Brass, Cu3 (CuZn39Pb3).

Technical Notes

To DIN 439. Standard metric coarse pitch threads.

Order No.	Thread	h min.	A/F	Material	Finish
B0507.020	M 2	0.95	4.0	Brass	unfinished
B0507.025	M2,5	1.35	5.0	Brass	unfinished
B0507.030	M 3	1.55	5.5	Brass	unfinished
B0507.040	M 4	1.95	7.0	Brass	unfinished
B0507.050	M 5	2.45	8.0	Brass	unfinished
B0507.060	M 6	2.9	10.0	Brass	unfinished
B0507.080	M 8	3.7	13.0	Brass	unfinished
B0507.100	M10	4.7	17.0	Brass	unfinished
B0507.120	M12	5.7	19.0	Brass	unfinished
B0507.140	M14	6.42	22.0	Brass	unfinished
B0507.160	M16	7.42	24.0	Brass	unfinished
B0507.180	M18	8.42	27.0	Brass	unfinished
B0507.200	M20	9.1	30.0	Brass	unfinished
B0507.220	M22	9.9	34.0	Brass	unfinished
B0507.240	M24	10.9	36.0	Brass	unfinished
B0507.270	M27	12.4	41.0	Brass	unfinished
B0507.300	M30	13.9	46.0	Brass	unfinished
B0507.330	M33	15.4	50.0	Brass	unfinished
B0507.360	M36	16.9	55.0	Brass	unfinished
B0507.420	M42	19.7	55.0	Brass	unfinished