

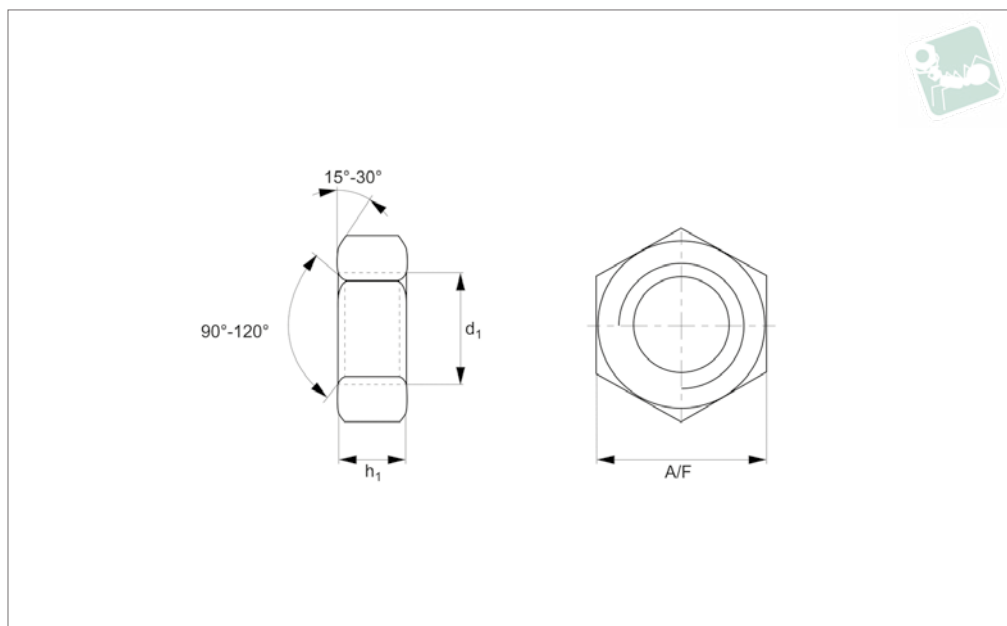

Hexagon Thin Nuts

unchamfered, DIN 439, Titanium G2

Titanium



T0509.T2

TITANIUM

Material
Titanium G2.

Technical Notes
To DIN 439. Standard metric coarse pitch threads.

Order No.	Thread	h_1	A/F	Material
T0509.020-T2-00	M 2	0.95	4	Titanium G2
T0509.030-T2-00	M 3	1.55	5.5	Titanium G2
T0509.040-T2-00	M 4	1.95	7.0	Titanium G2
T0509.050-T2-00	M 5	2.7	8	Titanium G2
T0509.060-T2-00	M 6	3.2	10	Titanium G2
T0509.080-T2-00	M 8	4.0	13	Titanium G2
T0509.100-125-T2-00	M10x1,25	4.7	17	Titanium G2
T0509.100-T2-00	M10	5.0	17	Titanium G2
T0509.120-T2-00	M12	5.7	19	Titanium G2
T0509.160-T2-00	M16	7.42	24	Titanium G2
T0509.200-T2-00	M20	9.1	30	Titanium G2
T0509.025-T2-00	M2.5	1.35	5	Titanium G2

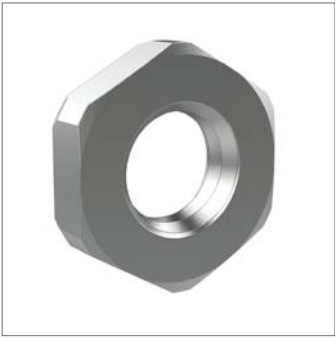

T0509.T5

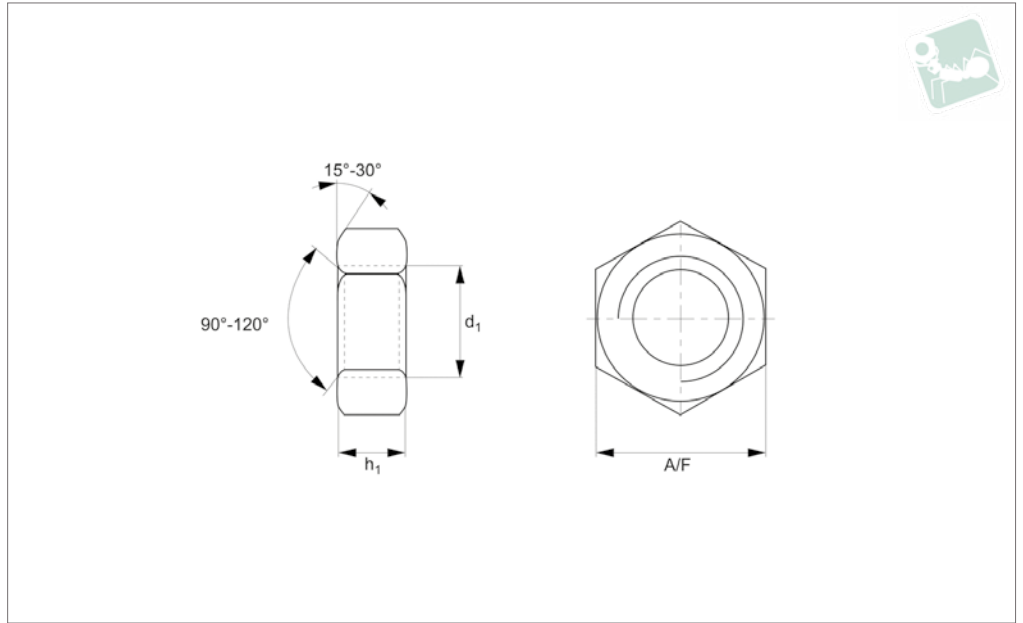

Material

Titanium 5 (6AL-4V).

Technical Notes

To DIN 439. Standard metric coarse pitch threads.

Order No.	Thread	h_1	A/F	Material
T0509.020-T5-00	M 2	0.95	4	Titanium 5 (6AL-4V)
T0509.030-T5-00	M 3	1.55	5.5	Titanium 5 (6AL-4V)
T0509.040-T5-00	M 4	1.95	7.0	Titanium 5 (6AL-4V)
T0509.050-T5-00	M 5	2.7	8	Titanium 5 (6AL-4V)
T0509.060-T5-00	M 6	3.2	10	Titanium 5 (6AL-4V)
T0509.080-T5-00	M 8	4.0	13	Titanium 5 (6AL-4V)
T0509.100-125-T5-00	M10x1,25	4.7	17	Titanium 5 (6AL-4V)
T0509.100-T5-00	M10	5.0	17	Titanium 5 (6AL-4V)
T0509.120-T5-00	M12	5.7	19	Titanium 5 (6AL-4V)
T0509.160-T5-00	M16	7.42	24	Titanium 5 (6AL-4V)
T0509.200-T5-00	M20	9.1	30	Titanium 5 (6AL-4V)
T0509.025-T5-00	M2.5	1.35	5	Titanium 5 (6AL-4V)



Flanged Nuts

Flanged, DIN 6923, Titanium G2

Titanium

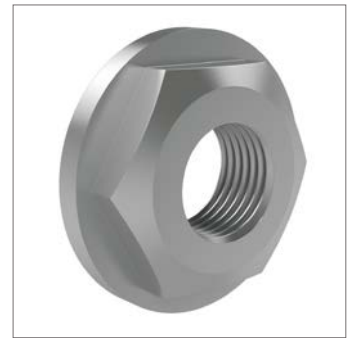
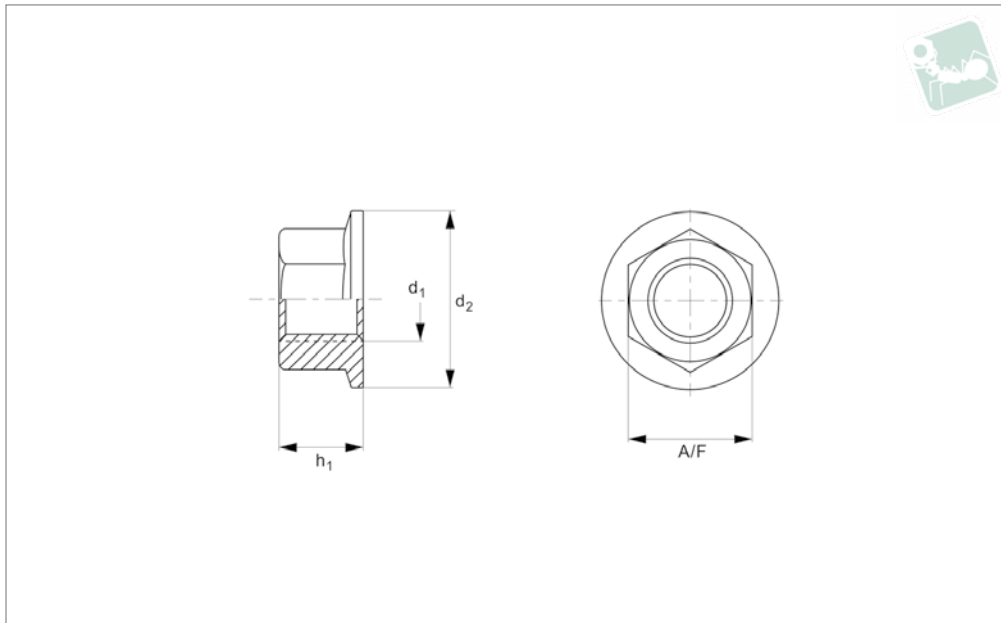

T0530.T2

TITANIUM

Material
Titanium G2.

Technical Notes
To DIN 6923.

Order No.	d_1	d_2 max.	h_1	A/F
T0530.040-T2	M 4	10.0	4.65	7
T0530.050-T2	M 5	11.8	5	8
T0530.060-T2	M 6	14.2	6	10
T0530.080-T2	M 8	17.9	8	13
T0530.100-T2	M10	21.8	10	15
T0530.120-T2	M12	26.0	12	18

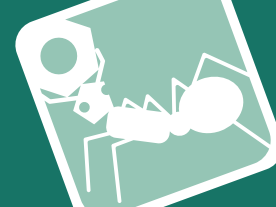

TITANIUM

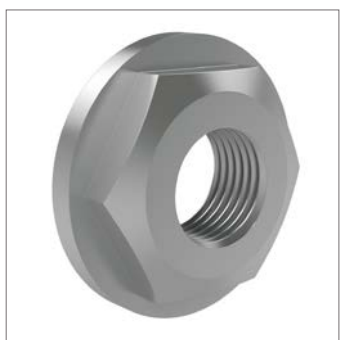

T0530.T5

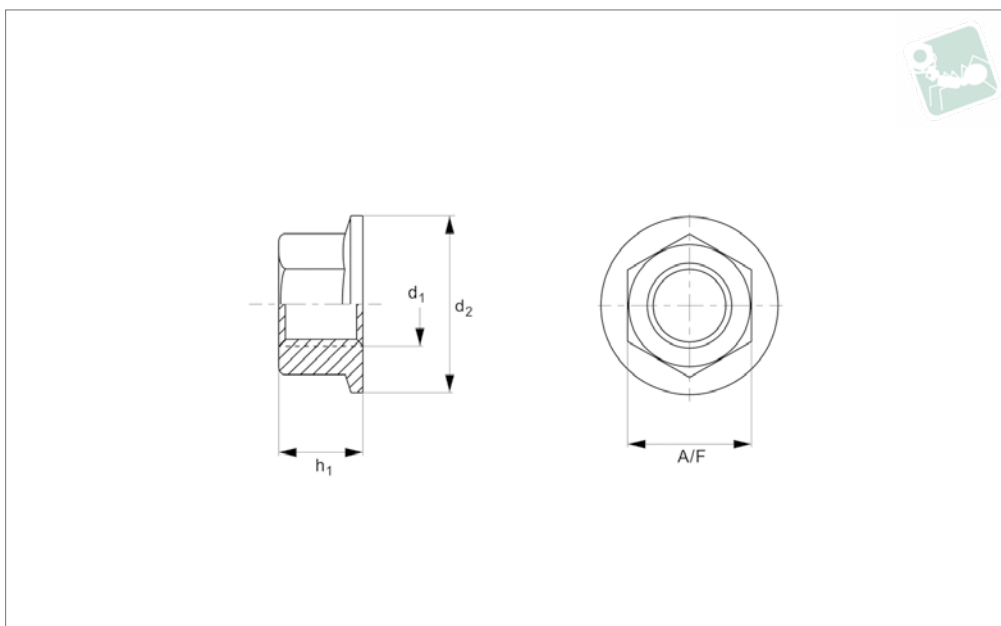

Material

Titanium 5 (6AL-4V).

Technical Notes

To DIN 6923.

Order No.	d_1	d_2 max.	h_1	A/F
T0530.040-T5	M 4	10.0	4.65	7
T0530.050-T5	M 5	11.8	5	8
T0530.060-T5	M 6	14.2	6	10
T0530.080-T5	M 8	17.9	8	13
T0530.100-T5	M10	21.8	10	15
T0530.120-T5	M12	26	12	18



Flanged Nuts

Flanged, DIN 6929, Titanium G2

Titanium

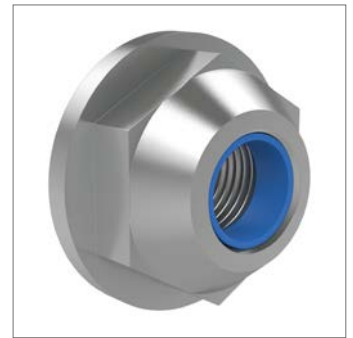
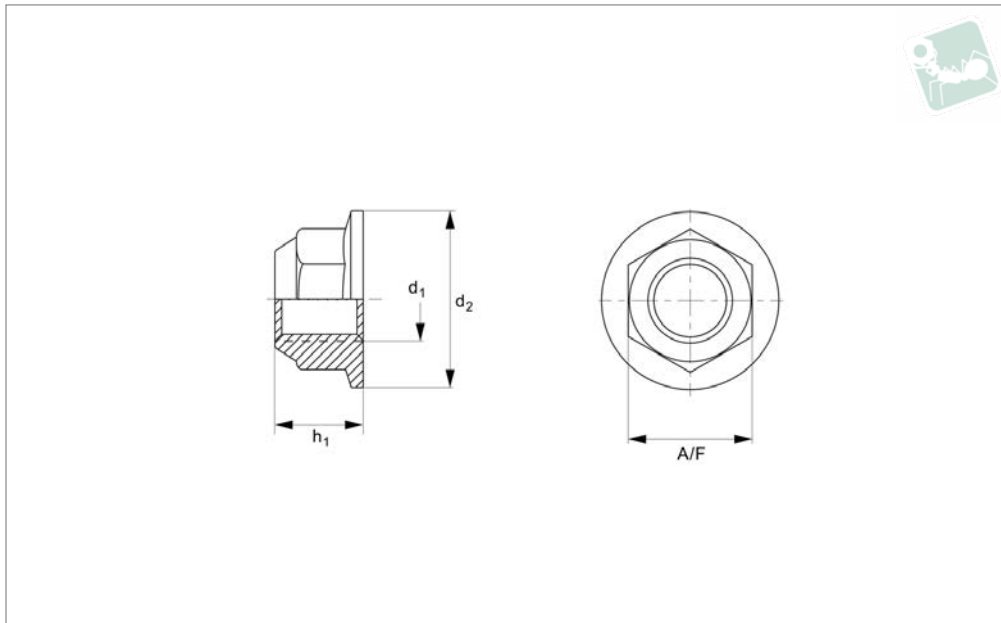

T0533.T2

TITANIUM

Material
Titanium G2.

Technical Notes
To DIN 6923.

Order No.	d ₁	d ₂	h ₁	h ₂	A/F
T0533.050-T2	M 5	11.8	7.1	2.2	8
T0533.060-T2	M 6	14.2	9.1	3.1	10
T0533.080-T2	M 8	17.9	11.1	4.5	13
T0533.100-T2	M10	21.8	13.5	5.5	15
T0533.120-T2	M12	26.0	16.1	6.7	18

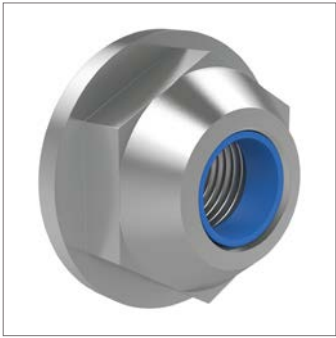

T0533.T5

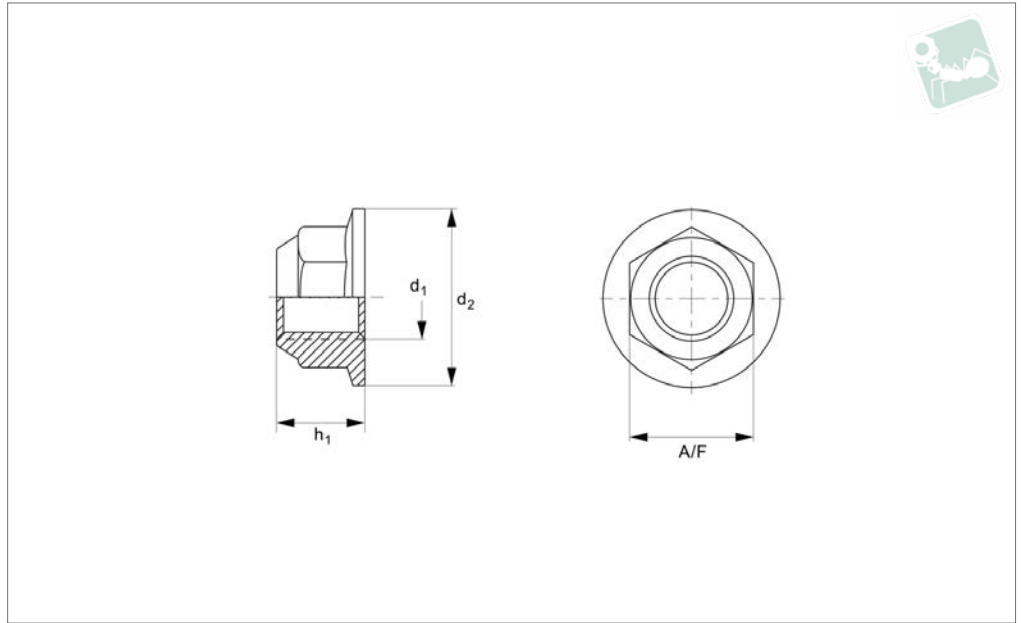

Material

Titanium 5 (6AL-4V).

Technical Notes

To DIN 6923.

Order No.	d_1	d_2	h_1	A/F
T0533.050-T5	M 5	11.8	5	8
T0533.060-T5	M 6	14.2	6	10
T0533.080-T5	M 8	17.9	8	13
T0533.100-T5	M10	21.8	10	15
T0533.120-T5	M12	26.0	12	18



T0536

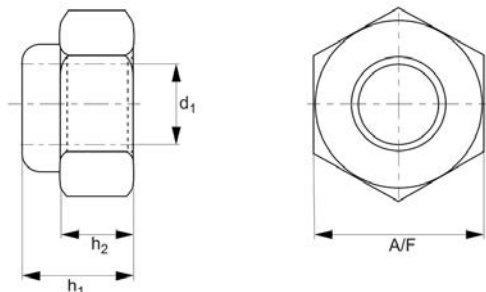

TITANIUM

Material

Titanium Grade 2 (commercial grade, high corrosion resistance, strong weldability, standard strength).

Titanium Grade 5 (aerospace grade Ti 6Al-4V Titanium alloy, good strength to weight ratio, corrosion resistant).

Technical Notes

Items to DIN 985 where stated in data table.

Order No.	d ₁	h ₁	h ₂	A/F	Material	Grade	Finish	To standard
T0536.030.2AD	M 3	4	2.4	5.5	Ti-G2	Comm	Natural	DIN 985
T0536.040.2AD	M 4	5	2.9	7.0	Ti-G2	Comm	Natural	DIN 985
T0536.050.2AD	M 5	5	3.2	8.0	Ti-G2	Comm	Natural	DIN 985
T0536.060.2AD	M 6	6	4.0	10.0	Ti-G2	Comm	Natural	DIN 985
T0536.080.2AD	M 8	8	5.5	13.0	Ti-G2	Comm	Natural	DIN 985
T0536.100.2AD	M10	10	6.5	17.0	Ti-G2	Comm	Natural	DIN 985
T0536.120.2AD	M12	12	8.0	19.0	Ti-G2	Comm	Natural	DIN 985
T0536.140.2AD	M14	14	9.5	22.0	Ti-G2	Comm	Natural	DIN 985
T0536.160.2AD	M16	16	13.0	24.0	Ti-G2	Comm	Natural	DIN 985
T0536.200.2AD	M20	20	14.0	30.0	Ti-G2	Comm	Natural	DIN 985
T0536.030.5AD	M 3	4	2.4	5.5	Ti-G5	Aero	Natural	DIN 985
T0536.040.5AD	M 4	5	2.9	7.0	Ti-G5	Aero	Natural	DIN 985
T0536.050.5AD	M 5	5	3.2	8.0	Ti-G5	Aero	Natural	DIN 985
T0536.060.5AD	M 6	6	4.0	10.0	Ti-G5	Aero	Natural	DIN 985
T0536.080.5AD	M 8	8	5.5	13.0	Ti-G5	Aero	Natural	DIN 985
T0536.100.5AD	M10	10	6.5	17.0	Ti-G5	Aero	Natural	DIN 985
T0536.120.5AD	M12	12	8.0	19.0	Ti-G5	Aero	Natural	DIN 985
T0536.140.5AD	M14	14	9.5	22.0	Ti-G5	Aero	Natural	DIN 985
T0536.160.5AD	M16	16	13.0	24.0	Ti-G5	Aero	Natural	DIN 985
T0536.200.5AD	M20	20	14.0	30.0	Ti-G5	Aero	Natural	DIN 985

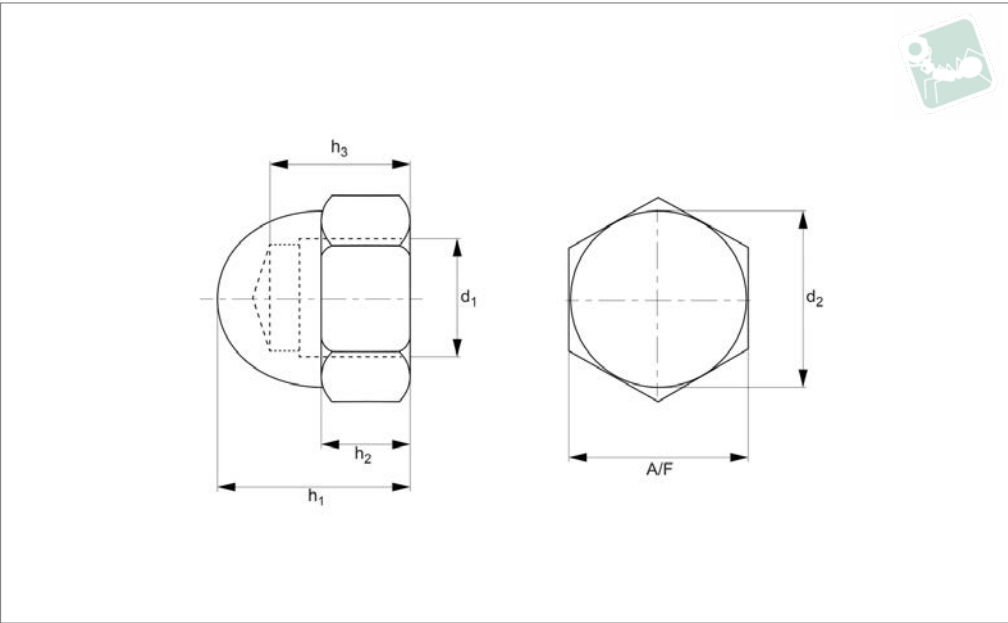
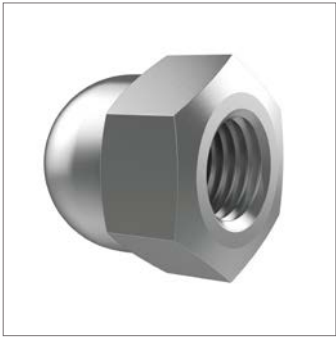

TITANIUM

T0542.T2

Material
 Titanium G2.

Technical Notes
 To DIN 1587.

Order No.	Thread	d ₂	h ₁	h ₂	h ₃	A/F
T0542.050-T2-00	M 5	7.5	10	4.0	7.5	8
T0542.060-T2-00	M 6	9.5	12	5.0	8.0	10
T0542.080-T2-00	M 8	12.5	15	6.5	11.0	13
T0542.100-T2-00	M10	16.0	18	8.0	13.0	16
T0542.100-125-T2-00	M10x1,25	-	18	8.0	-	16
T0542.120-T2-00	M12	18.0	22	10.0	16.0	19



Hexagon Domed Cap Nuts

Domed Cap Nuts, DIN 1587, Titanium 5

Titanium

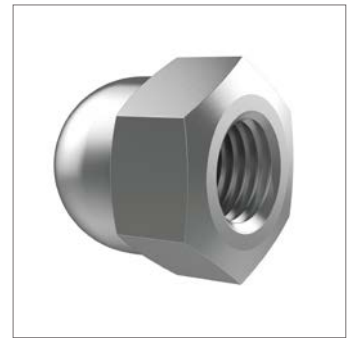
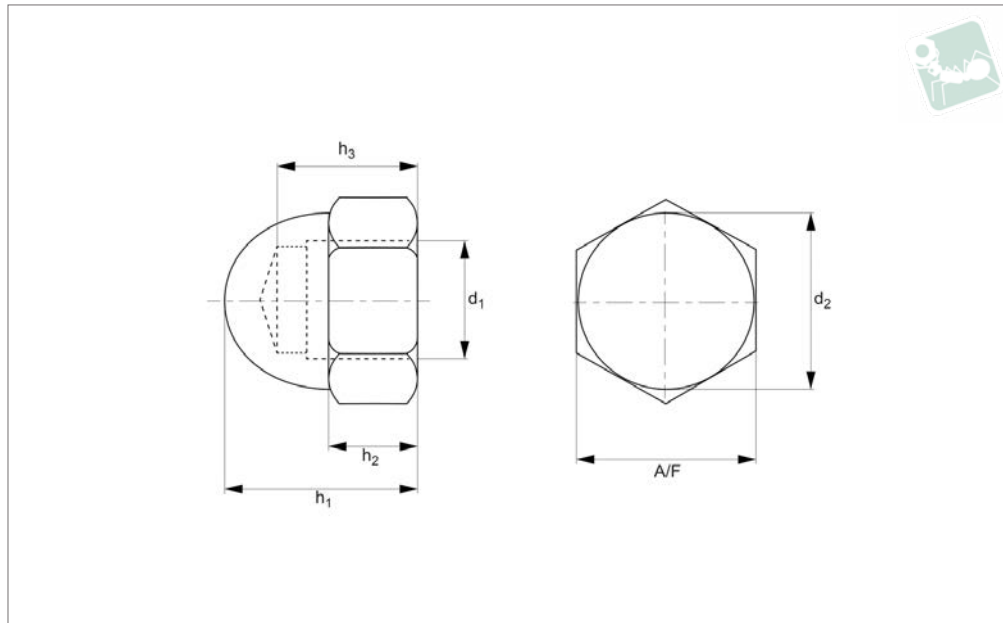

T0542.T5

TITANIUM

Material
Titanium 5 (6AL-4V).

Technical Notes
To DIN 1587.

Order No.	Thread	d_2	h_1	h_2	h_3	A/F
T0542.050-T5-00	M 5	7.5	10	4.0	7.5	8
T0542.060-T5-00	M 6	9.5	12	5.0	8.0	10
T0542.080-T5-00	M 8	12.5	15	6.5	11.0	13
T0542.100-T5-00	M10	16.0	18	8.0	13.0	16
T0542.100-125-T5-00	M10x1,25	-	18	8.0	-	16
T0542.120-T5-00	M12	18.0	22	10.0	16.0	19



T0501

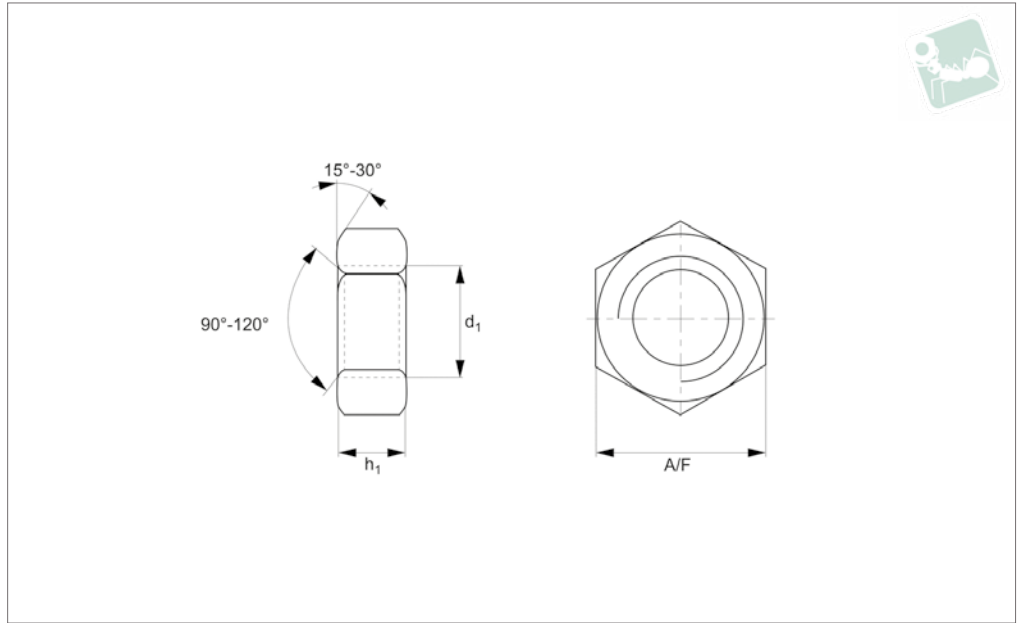

Material

Titanium Grade 2 (commercial grade, high corrosion resistance, strong weldability, standard strength).

Titanium Grade 5 (aerospace grade Ti 6Al-4V Titanium alloy, good strength to weight ratio, corrosion resistant).

Technical Notes

Items to DIN 934 where stated in data table

Order No.	d ₁	h ₁	A/F	Material
T0501.016.2AD	M1,6	1.3	3.2	Grade 2
T0501.020.2AD	M 2	1.6	4.0	Grade 2
T0501.030.2AD	M 3	2.4	5.5	Grade 2
T0501.040.2AD	M 4	3.2	7.0	Grade 2
T0501.050.2AD	M 5	4.0	8.0	Grade 2
T0501.060.2AD	M 6	5.0	10.0	Grade 2
T0501.080.2AD	M 8	6.5	13.0	Grade 2
T0501.100.2AD	M10	8.0	17.0	Grade 2
T0501.120.2AD	M12	10.0	19.0	Grade 2
T0501.140.2AD	M14	11.0	22.0	Grade 2
T0501.160.2AD	M16	13.0	24.0	Grade 2
T0501.200.2AD	M20	16.0	27.0	Grade 2
T0501.030.5AD	M 3	2.4	5.5	Grade 5
T0501.040.5AD	M 4	3.2	7.0	Grade 5
T0501.050.5AD	M 5	4.0	8.0	Grade 5
T0501.060.5AD	M 6	5.0	10.0	Grade 5
T0501.080.5AD	M 8	6.5	13.0	Grade 5
T0501.100.5AD	M10	8.0	17.0	Grade 5
T0501.120.5AD	M12	10.0	19.0	Grade 5
T0501.140.5AD	M14	11.0	22.0	Grade 5
T0501.160.5AD	M16	13.0	24.0	Grade 5
T0501.200.5AD	M20	16.0	27.0	Grade 5