

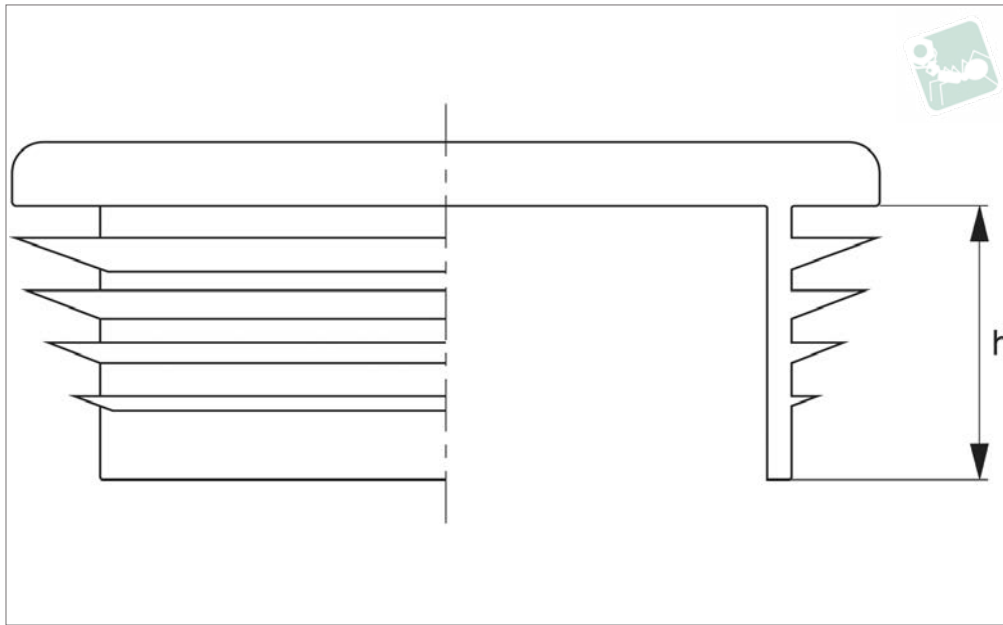

Inserts

ribbed - rectangular

Other Plastics



08003.N3

OTHER PLASTICS

Material

Low density polyethylene, black.

Important Notes

Sold subject to minimum pack quantity.

Technical Notes

Insert ribs provide secure fitting.

Order No.	External cap dim.	Tube wall thickness	h
08003.AC0992	20x10	1,0-2,0	11,0
08003.AC0994	20x15	1,0-2,0	11,5
08003.AC0997	25x10	1,0-1,5	11,5
08003.AC0999	25x15	1,0-2,5	11,5
08003.AC1002	25x20	1,0-3,0	11,5
08003.AC1004	30x10	1,0-1,5	11,5
08003.AC1006	30x15	1,0-2,5	11,5
08003.AC1008	30x20	1,5-3,0	11,5
08003.AC1013	30x25	1,5	13,0
08003.AC1015	35x10	1,0-2,0	11,5
08003.AC1016	35x20	1,0-2,5	11,5
08003.AC1017	35x15	1,0-3,0	11,5
08003.AC1018	35x25	1,0-3,0	11,5
08003.AC1022	40x10	1,5	10,5
08003.AC1024	40x15	1,0-1,5	12,0
08003.AC1027	40x20	1,0-2,0	12,0
08003.AC1030	40x25	1,0-3,0	11,5
08003.AC1032	40x30	1,0-3,0	12,0
08003.AC1036	40x35	1,0-3,0	12,0
08003.AC1037	45x15	1,5-2,0	11,0
08003.AC1039	45x20	1,5-2,0	11,5
08003.AC1041	45x25	1,5-2,0	14,0
08003.AC1042	45x30	1,0-2,5	12,0
08003.AC1043	45x35	1,0-3,5	12,0
08003.AC1044	50x10	1,0-1,5	12,0
08003.AC1046	50x20	1,0-3,0	14,0
08003.AC1048	50x25	1,5-2,5	14,5
08003.AC1049	50x30	1,5-2,0	13,5
08003.AC1051	50x30	3,0	14,0
08003.AC1053	50x35	1,0-3,5	14,5
08003.AC1054	50x40	1,5-2,5	12,5
08003.AC1056	55x34	1,5	14,0
08003.AC1057	55x40	1,5-4,0	14,5
08003.AC1058	60x15	1,0-2,0	14,5



Order No.	External cap dim.	Tube wall thickness	h
08003.AC1060	60x20	1,0-3,0	14.5
08003.AC1061	60x25	1,0-2,5	14.0
08003.AC1063	60x30	1,5-2,0	15.0
08003.AC1064	60x35	1,5-3,5	15.0
08003.AC1065	60x40	1,0-3,0	14.0
08003.AC1066	60x40	4,0-5,0	14.0
08003.AC1067	60x45	1,5-4,0	15.0
08003.AC1068	60x50	1,5-3,5	14.5
08003.AC1069	65x35	1,0-3,0	15.0
08003.AC1070	70x20	1,0-2,0	17.0
08003.AC1071	70x25	1,5-2,0	17.0
08003.AC1072	70x30	1,5-2,0	18.0
08003.AC1073	70x40	1,5-2,0	18.0
08003.AC1074	70x40	2,0-5,0	15.0
08003.AC1077	80x20	1,5-2,0	18.0
08003.AC1078	80x30	1,0-2,5	14.5
08003.AC1080	80x30	2,5-4,0	14.5
08003.AC1082	80x40	1,0-3,0	14.5
08003.AC1084	80x40	3,2-4,0	24.5
08003.AC1086	80x50	2,0-4,0	24.0
08003.AC1087	80x60	2,5-3,0	24.0
08003.AC1088	80x60	5.0	18.5
08003.AC1089	100x30	1,5-3,0	15.0
08003.AC1090	100x40	2,0-4,0	14.5
08003.AC1094	100x50	2,0-3,0	24.0
08003.AC1096	100x50	3,2-5,0	24.0
08003.AC1097	120x30	1,5-2,0	14.5
08003.AC1098	120x40	2.0	-
08003.AC1100	120x40	3,0-5,0	21.5
08003.AC1102	120x60	2,0-4,0	24.5
08003.AC1105	120x80	2,0-3,0	24.0
08003.AC1106	120x80	5,0-8,0	25.0
08003.AC1108	140x80	2,0-4,5	20.0
08003.AC1109	150x100	3,0-8,0	27.0



Insert ribbed - oval

Other Plastics

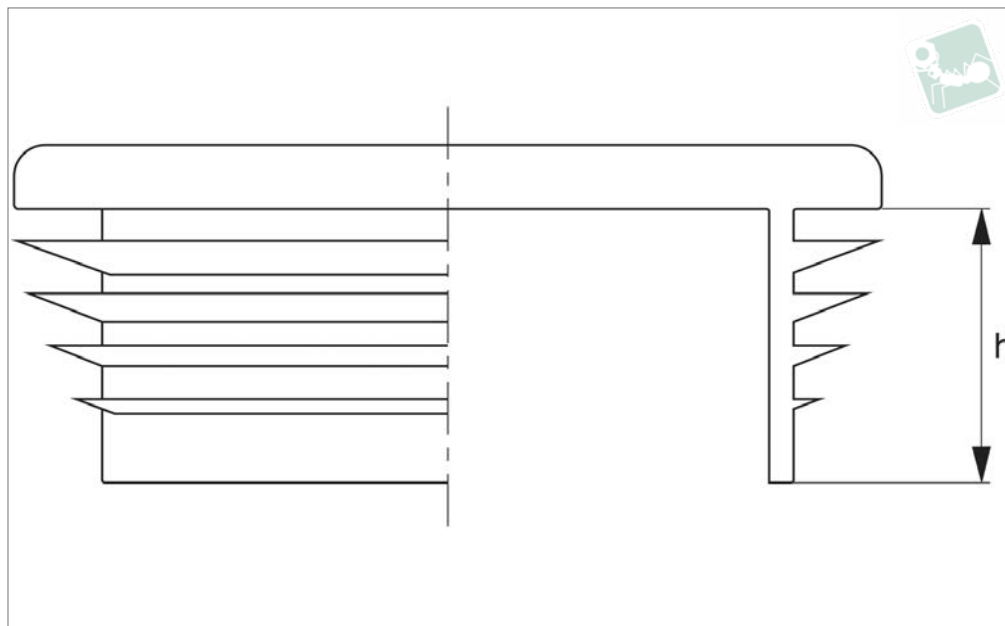

08006.N3

OTHER PLASTICS

Material

Low density polyethylene, black.

Important Notes

Sold subject to minimum pack quantity.

Technical Notes

Insert ribs provide secure fitting.

Order No.	External tube dimension a x b	Tube wall thickness	h ₁	h ₂
08006.AC0001	20x10	2.0	5	10
08006.AC0003	30x15	1,0-2,5	5	12
08006.AC0005	35x15	1,2-2,5	5	12
08006.AC0007	35x20	1,0-3,0	5	12
08006.AC0009	38x20	1,0-3,0	5	12
08006.AC0011	40x20	1,0-3,0	5	12
08006.AC0013	45x20	1,5-3,0	5	12
08006.AC0015	48x20	1,0-2,5	5	12
08006.AC0017	50x15	1,0-2,5	5	12
08006.AC0019	50x20	1,0-3,0	5	12
08006.AC0021	50x25	1,0-2,5	5	12
08006.AC0023	50x30	1,0-2,5	5	12
08006.AC0025	60x20	1,0-2,0	5	13
08006.AC0027	60x25	1,5-3,0	5	13
08006.AC0029	60x30	1,0-2,0	5	13



08000.N3

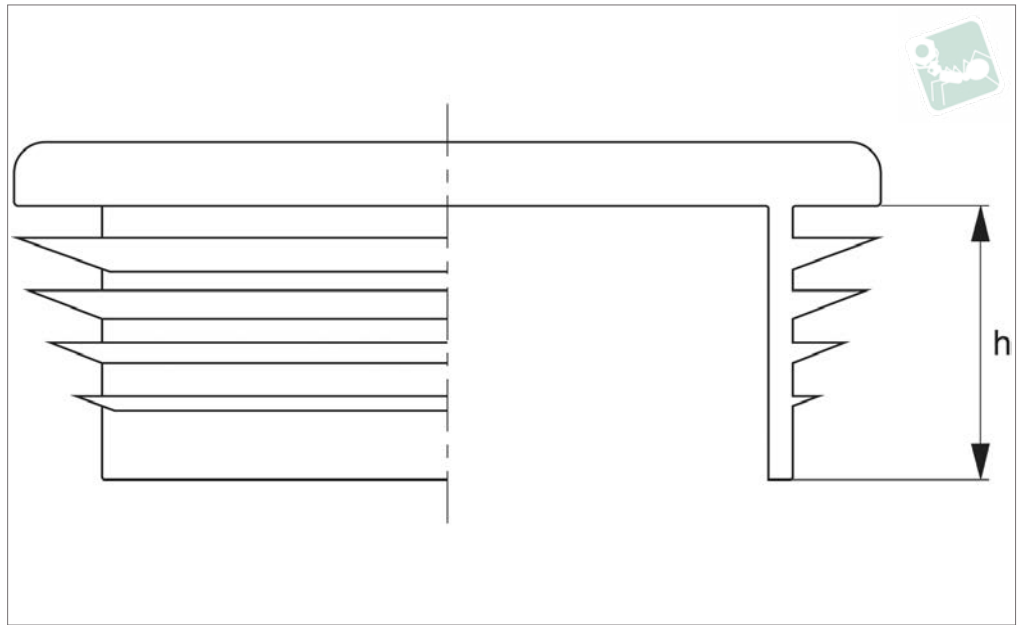

Material

Low density polyethylene, black.

Important Notes

Sold subject to minimum pack quantity.

Technical Notes

Insert ribs provide secure fitting.

Order No.	External cap dim.	Tube wall thickness	h
08000.AC0208	90x90	3,6-5,0	6.0
08000.AC0151	10x10	1,5-2,0	12.0
08000.AC0153	12x12	1,5-2,0	12.0
08000.AC0155	13x13	1,5-2,0	12.0
08000.AC0157	15x15	1,5-2,0	14.0
08000.AC0159	16x16	1,5-2,0	11.5
08000.AC0162	18x18	1,5-2,0	11.5
08000.AC0164	20x20	1,0-3,0	11.0
08000.AC0166	22x22	1,0-3,0	12.0
08000.AC0168	25x25	1,0-3,0	11.5
08000.AC0174	28x28	1,5-3,0	11.5
08000.AC0176	30x30	1,0-2,5	11.5
08000.AC0177	30x30	2,5-4,5	11.5
08000.AC0182	35x35	1,0-3,0	14.5
08000.AC0184	35x35	2,5-5,0	12.0
08000.AC0186	40x40	1,0-3,0	14.0
08000.AC0188	40x40	2,5-4,0	18.0
08000.AC0189	40x40	5,0-5,5	14.0
08000.AC0192	45x45	1,0-3,0	14.5
08000.AC0196	50x50	2,6-4,0	25.0
08000.AC0198	50x50	3,5-6,0	14.5
08000.AC0200	60x60	1,5-3,5	24.0
08000.AC0201	60x60	3,0-5,0	17.5
08000.AC0203	70x70	2,0-4,0	19.0
08000.AC0206	80x80	3,0-5,0	24.0
08000.AC0210	100x100	1,0-4,0	24.0
08000.AC0211	100x100	5,0-8,0	24.0
08000.AC0213	120x120	2,5-5,0	25.0
08000.AC0219	150x150	5,0-8,0	-
08000.AC0221	150x150	10,0-12,5	27.0



Inserts ribbed - round

Other Plastics

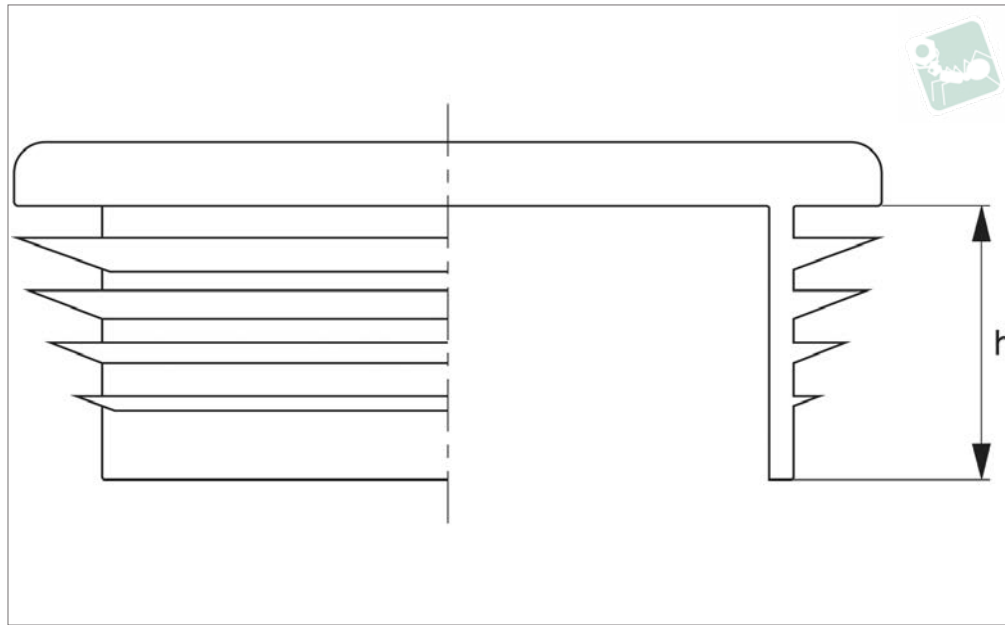

08009.N3

OTHER PLASTICS

Material

Low density polyethylene, black.

Important Notes

Sold subject to minimum pack quantity.

Technical Notes

insert ribs provide secure fitting.

Order No.	External cap dia.	Tube wall thickness	h
08009.AC0301	10	1,0-2,0	11,0
08009.AC0303	12	1,0-2,0	11,0
08009.AC0305	13	1,0-2,0	11,0
08009.AC0307	14	1,0-2,0	11,5
08009.AC0309	15	1,0-2,0	13,0
08009.AC0311	16	1,0-2,0	11,0
08009.AC0313	18	1,0-2,0	11,4
08009.AC0314	19	1,0-2,0	11,4
08009.AC0315	20	1,0-2,0	11,4
08009.AC0316	21	1,0-2,0	11,5
08009.AC0317	22	1,0-2,0	11,5
08009.AC0318	23	1,0-2,5	11,5
08009.AC0320	25	1,0-3,0	11,5
08009.AC0322	27	1,0-3,0	11,5
08009.AC0323	28	1,0-2,0	11,5
08009.AC0325	30	1,0-2,0	11,6
08009.AC0327	32	1,0-2,0	11,5
08009.AC0328	34	1,0-3,0	11,5
08009.AC0331	35	1,0-2,0	11,5
08009.AC0333	36	1,0-2,0	11,5
08009.AC0336	38	1,0-3,5	11,5
08009.AC0338	40	1,0-3,0	11,5
08009.AC0339	42	1,0-2,0	11,5
08009.AC0340	42	2,0-4,0	11,5
08009.AC0342	45	1,0-3,5	11,0
08009.AC0344	48	1,2-3,6	11,5
08009.AC0345	50	1,0-2,0	11,5
08009.AC0346	52	1,5-3,5	14,5
08009.AC0348	55	1,0-3,0	11,5
08009.AC0350	60	1,5-3,0	18,5
08009.AC0351	60	3,0-4,0	21,0
08009.AC0352	65	1,5-3,5	21,0
08009.AC0353	70	2,0-4,5	21,0
08009.AC0355	76	1,6-4,0	21,5



Order No.	External cap dia.	Tube wall thickness	h
08009.AC0358	80	1,5-3,0	21.0
08009.AC0359	90	2,5-5,0	19.9
08009.AC0360	95	1,5-4,0	21.0
08009.AC0361	102	2,0-4,0	20.2
08009.AC0362	100	2,0-4,5	28.5
08009.AC0363	105	2,0-4,5	29.0
08009.AC0364	110	2,0-4,5	28.5
08009.AC0365	120	2,0-4,0	28.5



Tube End Caps

push-fit

Other Plastics

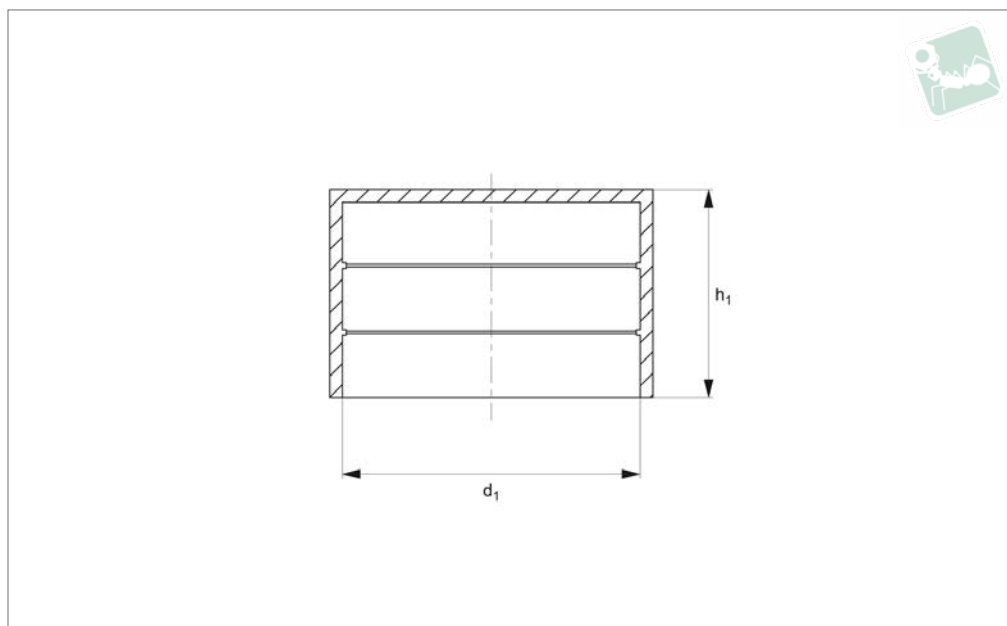

08200.N3

OTHER PLASTICS

Material

Low density polyethylene.
Natural colour/yellow.

Important Notes

Sold subject to minimum pack quantity.

Order No.	Ext. tube dia. d_1 mm	Ext. tube dia. inch	h_1
08200.AC0001	4.0	-	22.0
08200.AC0003	6.0	-	18.0
08200.AC0005	6.0	-	18.0
08200.AC0007	6.35	-	18.0
08200.AC0009	7.0	-	18.0
08200.AC0011	8.0	-	19.0
08200.AC0013	9.6	1/8"	18.0
08200.AC0015	10.0	1/8"	18.0
08200.AC0017	11.0	-	15.0
08200.AC0019	12.0	-	18.0
08200.AC0021	12.7	-	18.0
08200.AC0023	13.0	1/4"	18.0
08200.AC0025	13.7	1/4"	18.0
08200.AC0027	14.0	-	20.0
08200.AC0029	15.0	-	19.0
08200.AC0031	15.5	-	19.5
08200.AC0033	16.0	-	20.0
08200.AC0035	17.2	3/8"	20.0
08200.AC0037	18.0	-	20.0
08200.AC0039	18.5	-	20.0
08200.AC0041	19.0	-	20.0
08200.AC0043	20.0	-	20.0
08200.AC0045	21.3	1/2"	16.0
08200.AC0047	22.0	-	20.0
08200.AC0049	23.2	-	19.0
08200.AC0051	24.0	-	20.0
08200.AC0055	25.4	-	20.0
08200.AC0057	26.0	-	20.0
08200.AC0059	26.9	3/4"	20.0
08200.AC0061	28.5	-	24.0
08200.AC0063	30.0	-	25.0
08200.AC0065	31.8	-	20.0
08200.AC0067	33.7	1"	20.0
08200.AC0069	35.0	-	25.0



Order No.	Ext. tube dia. d ₁ mm	Ext. tube dia. inch	h ₁
08200.AC0071	38.0	-	20.0
08200.AC0075	40.0	-	25.0
08200.AC0077	41.3	-	20.0
08200.AC0079	42.4	1,1/4"	25.3
08200.AC0081	44.5	-	25.0
08200.AC0083	45.4	-	20.0
08200.AC0085	47.5	-	25.0
08200.AC0087	48.3	1,1/2"	25.0
08200.AC0089	51.0	-	27.5
08200.AC0091	52.0	-	28.0
08200.AC0093	52.8	-	28.0
08200.AC0095	54.0	1,3/4"	27.5
08200.AC0097	55.0	-	29.0
08200.AC0099	57.0	-	26.5
08200.AC0101	59.0	-	27.0
08200.AC0103	60.3	2"	27.0
08200.AC0105	63.5	-	27.0
08200.AC0107	65.0	-	35.0
08200.AC0109	67.0	-	35.0
08200.AC0111	70.0	-	35.5
08200.AC0113	73.0	2,1/2"	30.0
08200.AC0115	75.0	-	28.0
08200.AC0117	76.0	2,1/2"	30.0
08200.AC0119	77.0	-	35.0
08200.AC0121	78.0	-	29.5
08200.AC0123	80.0	-	29.5
08200.AC0127	82.0	-	30.0
08200.AC0129	83.0	2,3/4"	30.0
08200.AC0131	85.0	-	30.0
08200.AC0133	88.9	3"	35.0
08200.AC0135	92.4	-	25.0
08200.AC0137	95.0	-	37.5
08200.AC0139	98.0	-	37.5
08200.AC0141	100.0	-	31.0
08200.AC0143	101.6	3,1/2"	30.0
08200.AC0145	103.0	-	35.0
08200.AC0151	105.0	-	40.0
08200.AC0153	108.0	-	35.0
08200.AC0155	110.0	-	38.0
08200.AC0157	114.3	4"	33.0
08200.AC0159	116.3	-	38.5
08200.AC0161	117.5	-	38.5
08200.AC0163	121.0	-	38.0
08200.AC0165	125.0	-	35.0
08200.AC0169	127.0	4,1/2"	35.0
08200.AC0171	130.0	-	40.0
08200.AC0173	133.0	-	40.0
08200.AC0175	136.0	-	40.0
08200.AC0177	138.0	-	32.5
08200.AC0179	139.7	5"	33.5
08200.AC0181	141.3	5"	34.5
08200.AC0183	146.0	-	40.0
08200.AC0185	148.0	-	35.0
08200.AC0189	152.4	5,1/2"	40.0
08200.AC0191	156.0	-	40.0
08200.AC0193	159.0	-	37.0
08200.AC0195	165.0	-	40.0
08200.AC0197	168.3	6"	38.5
08200.AC0199	170.0	-	45.0
08200.AC0201	176.0	-	40.0
08200.AC0203	177.8	-	40.0
08200.AC0205	180.0	-	40.0
08200.AC0207	185.0	-	40.0
08200.AC0209	190.0	-	40.0
08200.AC0211	193.7	-	42.0
08200.AC0213	200.0	-	50.0
08200.AC0215	210.0	-	40.0
08200.AC0217	219.1	8"	44.0



Tube End Caps push-fit

Other Plastics

Order No.	Ext. tube dia. d_1 mm	Ext. tube dia. inch	h_1
08200.AC0219	225.0	-	39.0
08200.AC0221	232.0	-	40.0
08200.AC0223	242.0	-	50.0
08200.AC0225	245.0	-	49.0
08200.AC0227	250.0	-	47.0
08200.AC0229	267.0	-	43.0
08200.AC0231	273.0	10"	49.0
08200.AC0237	323.9	12"	55.0
08200.AC0239	355.6	14"	56.0
08200.AC0241	366.0	-	54.0
08200.AC0243	400.0	-	65.0
08200.AC0247	406.4	16"	60.5
08200.AC0249	450.0	-	65.0
08200.AC0251	457.2	18"	63.0
08200.AC0253	508.0	20"	65.0
08200.AC0255	558.8	22"	60.0
08200.AC0257	609.6	24"	61.0
08200.AC0259	660.4	26"	115.0
08200.AC0261	711.2	28"	115.0
08200.AC0263	762.0	30"	115.0
08200.AC0265	812.4	32"	115.0
08200.AC0267	914.4	36"	115.0
08200.AC0269	1016.0	40"	115.0
08200.AC0271	1066.8	42"	115.0
08200.AC0273	1117.6	44"	125.0
08200.AC0275	1219.2	48"	115.0
08200.AC0277	1320.8	52"	150.0
08200.AC0281	1422.4	56"	150.0
08200.AC0283	1524.0	60"	150.0
08200.AC0285	1625.6	64"	150.0



08203.N3

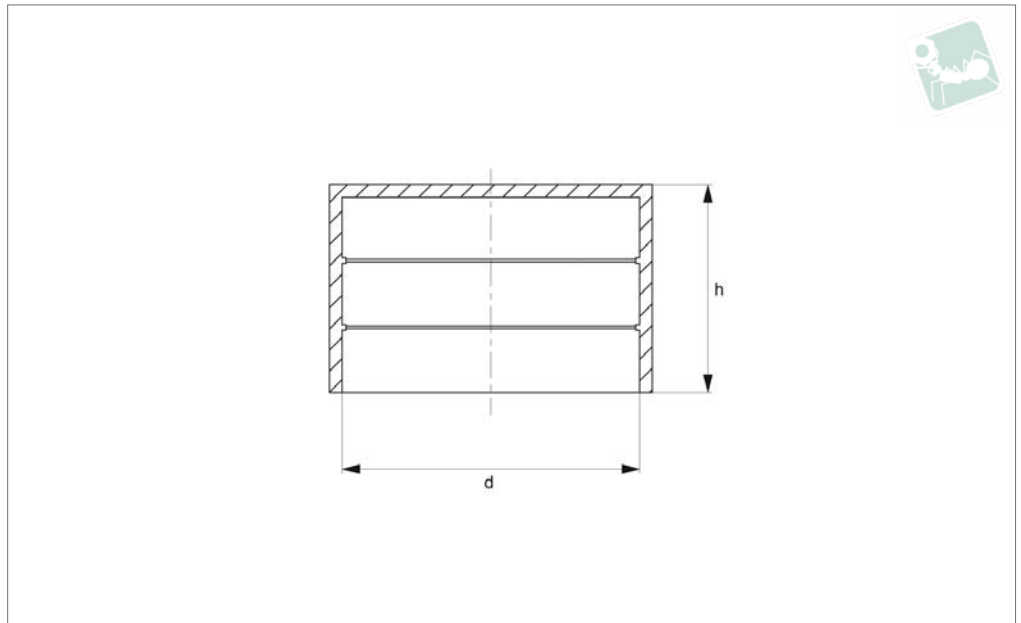

Material
PVC, black.

flexible PVC.

Technical Notes

For a wide range of applications, durable a

Important Notes

Sold subject to minimum pack quantity.

Order No.	External tube dia.	d	h
08203.AC0250	6,0	6,0	13,0
08203.AC0252	8,0	8,0	15,5
08203.AC0254	10,0-11,0	10,0	16,5
08203.AC0256	12,0-13,0	12,0	19,0
08203.AC0264	16,0-17,0	16,0	26,0
08203.AC0266	18,0	18,0	26,0
08203.AC0268	19,0	19,0	26,0
08203.AC0270	20,0	20,0	26,5
08203.AC0272	21,0	21,0	27,5
08203.AC0274	22,0-23,0	22,0	29,0
08203.AC0276	24,0	24,0	31,0
08203.AC0278	25,0-26,0	25,0	31,0
08203.AC0280	27,0	27,0	31,0
08203.AC0282	28,0-29,0	28,0	32,0
08203.AC0284	30,0-31,0	30,0	32,0
08203.AC0286	32,0-33,0	32,0	32,0
08203.AC0288	34,0	34,0	33,0
08203.AC0290	35,0-36,0	35,0	32,5
08203.AC0292	38,0-39,0	38,0	32,0
08203.AC0294	40,0-41,0	40,0	34,0
08203.AC0296	42,0	42,0	32,0
08203.AC0298	43,0-44,0	43,0	32,0
08203.AC0300	45,0-46,0	45,0	36,0
08203.AC0304	48,0	48,0	36,0
08203.AC0306	49,0-51,0	49,0	36,0
08203.AC0308	54,0-55,0	54,0	39,0
08203.AC0310	59,0-60,0	59,0	36,0
08203.AC0312	63,0-64,0	63,0	37,0
08203.AC0314	69,0-70,0	69,0	37,0
08203.AC0316	75,0-76,0	75,0	39,0
08203.AC0318	90,0-91,0	90,0	39,0



Barrel Plugs flat head

Other Plastics

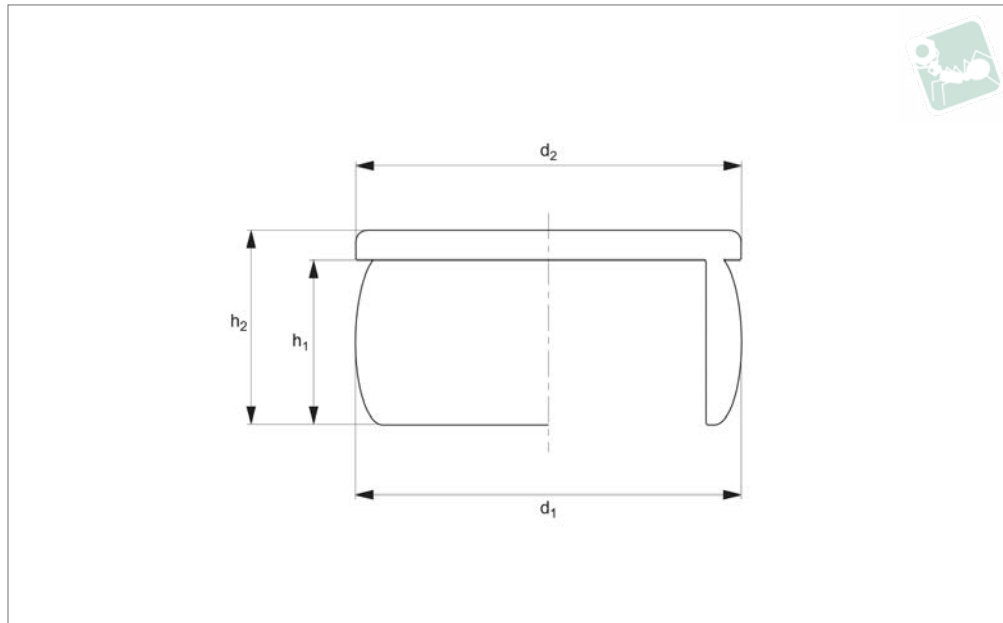

08206.N3

OTHER PLASTICS

Material

PVC, natural colour

ensures good fit.

Technical Notes

Wide range of applications. Barrel shape

Important Notes

Sold subject to minimum pack quantity.

Order No.	To fit thread	d_1	d_2	h_1	h_2
08206.AC0500	M8x1	7.3	14	6.0	8.0
08206.AC0502	M10	9.3	14	4.5	6.5
08206.AC0504	1/8" BSP	9.3	16	6.8	8.3
08206.AC0506	M12x1,5	10.7	14	5.5	7.5
08206.AC0508	M14	11.9	16	7.0	9.0
08206.AC0510	M14x1,5	12.8	20	7.8	10.3
08206.AC0512	-	13.7	20	8.0	10.0
08206.AC0514	M18	15.6	20	8.0	10.0
08206.AC0516	-	17.0	22	8.2	10.8
08206.AC0518	1/2" BSP	19.3	25	8.0	10.5
08206.AC0520	M22x1,5	20.5	30	10.7	13.2
08206.AC0522	5/8" BSP	21.2	25	7.5	9.5
08206.AC0524	M24x2,0	22.4	28	9.0	12.0
08206.AC0526	3/4" BSP	24.6	28	9.0	12.0
08206.AC0528	M27x1,5	25.5	28	7.5	9.5
08206.AC0530	M28x1,5	26.5	28	9.0	12.0
08206.AC0532	7/8" BSP	30.5	36	12.0	15.0
08206.AC0534	M33x1,5 / 1" BSP	31.8	36	10.0	12.5
08206.AC0536	M35x1,5	33.5	36	12.0	15.0



08209.N3

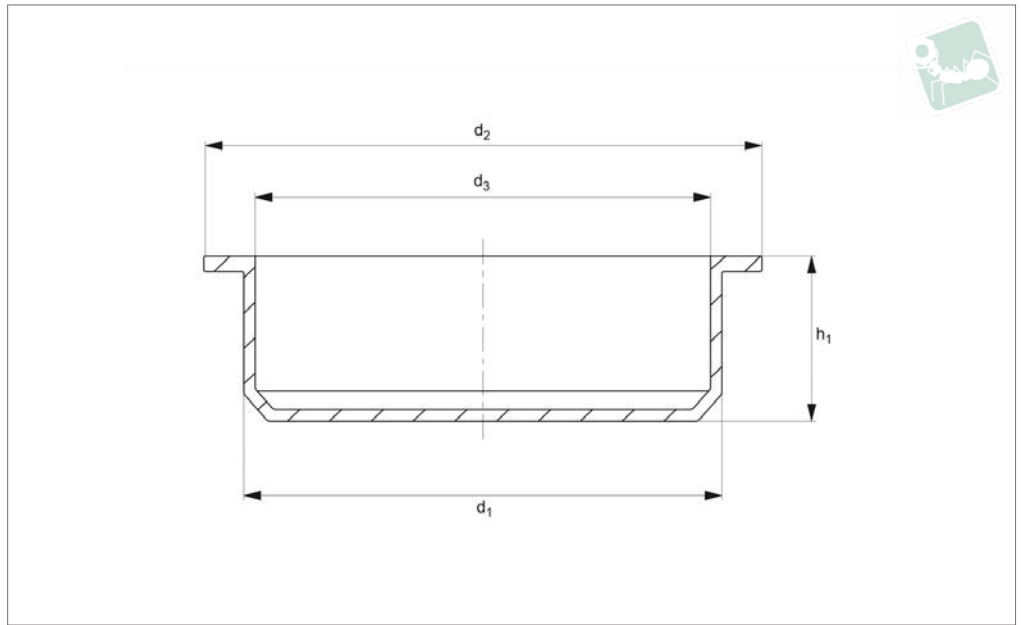

Material

Polyethylene, natural colour.

applications.

Technical Notes

General purpose for a wide range of appli-

Important Notes

Sold subject to minimum pack quantity.

Order No.	d_1	d_2	d_3	h_1	Thread	Thread inch
08209.AC0001	3.0	6.5	2.0	5.2	-	-
08209.AC0003	3.5	6.9	2.0	5.5	M 4	-
08209.AC0005	4.0	7.5	3.0	6	-	-
08209.AC0007	4.5	8.0	3.5	6.0	M 5	-
08209.AC0009	5.0	9.0	4.0	7.0	M 6	-
08209.AC0011	5.5	9.0	4.5	7.0	-	-
08209.AC0013	6.0	9.5	5.0	7.0	-	-
08209.AC0015	6.5	9.9	5.5	8.0	-	-
08209.AC0017	7.0	10.0	6.0	7.2	M 8	-
08209.AC0019	7.5	10.5	6.3	7.5	-	-
08209.AC0021	8.0	11.3	7.0	7.8	-	-
08209.AC0023	8.5	11.5	7.5	8.7	M10	-
08209.AC0025	9.0	11.8	8.0	8.6	-	1/8"
08209.AC0027	9.5	12.3	8.5	8.2	-	-
08209.AC0029	10.0	12.8	9.0	9.0	-	-
08209.AC0031	10.5	13.5	9.5	8.8	M12	-
08209.AC0033	11.0	14.0	10.0	9.0	-	-
08209.AC0035	11.5	14.5	10.5	9.0	-	-
08209.AC0037	12.0	15.3	11.0	9.2	-	1/4"
08209.AC0039	12.5	15.7	11.5	9.2	M14	-
08209.AC0041	13.0	16.3	12.0	10.0	-	-
08209.AC0043	13.5	16.5	12.5	10.0	-	-
08209.AC0045	14.0	17.0	13.0	10.2	-	-
08209.AC0047	14.5	17.5	13.5	10.2	M16	-
08209.AC0049	15.0	18.4	14.0	10.2	-	-
08209.AC0051	15.5	19.3	14.5	10.2	-	3/8"
08209.AC0053	16.0	20.0	15.0	11.0	M18	-
08209.AC0055	16.5	20.7	15.5	11.0	-	-
08209.AC0057	17.0	20.2	16.0	11.0	-	-
08209.AC0059	17.5	20.7	16.5	11.0	-	-
08209.AC0061	18.0	21.5	17.0	11.0	M20	-
08209.AC0063	18.5	23.0	17.5	11.0	-	-
08209.AC0065	19.0	22.7	18.0	11.2	-	1/2"
08209.AC0067	19.5	23.5	18.5	11.7	-	-



Parallel Protection Plug

push fit

Other Plastics

Order No.	d ₁	d ₂	d ₃	h ₁	Thread	Thread inch
08209.AC0069	20.0	23.5	19.0	11.7	M22	-
08209.AC0071	20.5	24.5	19.5	11.7	-	-
08209.AC0073	21.0	25.0	20.0	11.8	-	5/8"
08209.AC0075	21.5	25.5	20.0	12.0	M24	-
08209.AC0077	22.0	26.4	20.8	12.0	-	-
08209.AC0081	23.0	27.0	21.5	12.2	-	-
08209.AC0085	24.0	28.0	22.5	12.0	-	-
08209.AC0089	25.0	30.0	23.5	12.0	M27	3/4"
08209.AC0093	26.0	30.9	24.5	11.6	-	-
08209.AC0095	26.5	30.4	25.0	11.5	-	-
08209.AC0097	27.0	31.0	25.2	10.4	M30	-
08209.AC0101	28.0	31.3	26.0	11.5	-	-
08209.AC0105	29.0	32.0	27.0	10.5	-	7/8"
08209.AC0109	30.0	33.0	28.0	10.8	M33	-
08209.AC0113	31.0	35.0	29.0	11.8	-	1"
08209.AC0117	32.0	36.9	30.0	11.6	-	-
08209.AC0119	32.5	37.4	30.5	11.6	M36	-
08209.AC0123	33.0	37.7	31.0	11.4	-	-
08209.AC0127	34.0	38.5	32.0	11.7	-	-
08209.AC0131	35.0	40.0	33.0	11.4	-	-
08209.AC0135	36.0	41.2	34.0	12.0	M39	-
08209.AC0139	37.0	41.6	35.0	11.5	-	-
08209.AC0143	38.0	42.0	36.0	11.5	M42	-
08209.AC0147	39.0	43.8	37.0	11.3	-	-
08209.AC0151	40.0	44.5	38.0	11.5	-	1,1/4"
08209.AC0155	41.0	45.7	39.0	11.5	-	-
08209.AC0159	42.0	47.0	40.0	11.3	-	-
08209.AC0163	43.0	47.5	41.0	11.8	-	-
08209.AC0167	44.0	48.6	42.0	11.3	-	-
08209.AC0175	46.0	50.6	44.0	11.3	-	1,1/2"
08209.AC0179	47.0	51.3	45.0	11.3	-	-
08209.AC0183	48.0	53.2	46.0	11.5	-	-
08209.AC0187	49.0	53.7	47.0	11.5	-	-
08209.AC0191	50.0	54.1	48.0	11.0	-	-
08209.AC0195	51.0	54.5	49.0	10.8	-	-
08209.AC0199	52.0	60.0	50.0	12.0	-	-
08209.AC0203	53.0	59.0	51.0	11.9	-	-
08209.AC0207	54.0	60.5	52.0	12.0	-	-
08209.AC0211	55.0	61.2	53.0	12.0	-	-
08209.AC0215	56.0	62.4	54.0	13.0	-	-
08209.AC0219	57.0	60.2	55.0	10.8	-	-
08209.AC0223	58.0	64.6	56.0	11.7	-	-
08209.AC0227	59.0	66.7	57.0	10.7	-	-
08209.AC0231	60.0	67.3	58.0	12.0	-	-
08209.AC0235	61.0	67.1	59.0	12.5	-	-
08209.AC0239	62.0	68.7	60.0	12.2	-	-
08209.AC0243	63.0	66.5	61.0	11.0	-	-
08209.AC0245	63.5	69.5	61.0	11.5	-	-
08209.AC0247	64.0	67.2	62.0	10.7	-	-
08209.AC0251	65.0	68.7	63.0	11.5	-	-
08209.AC0255	66.0	71.5	64.0	11.7	-	-
08209.AC0259	67.0	73.0	65.0	11.5	-	-
08209.AC0263	68.0	74.2	66.0	11.8	-	-
08209.AC0267	69.0	75.0	67.0	11.9	-	-
08209.AC0271	70.0	74.2	68.0	12.1	-	-
08209.AC0275	71.0	75.0	69.0	12.5	-	-
08209.AC0279	72.0	79.0	70.0	13.0	-	-
08209.AC0283	73.0	76.5	71.0	12.0	-	-
08209.AC0287	74.0	77.0	72.0	11.8	-	-
08209.AC0291	75.0	78.5	72.5	11.2	-	-
08209.AC0295	76.0	78.8	74.0	11.5	-	-
08209.AC0299	77.0	80.5	75.0	11.0	-	-
08209.AC0303	78.0	81.7	76.0	11.7	-	-
08209.AC0307	79.0	82.0	77.0	11.0	-	-
08209.AC0311	80.0	83.5	78.0	10.7	-	-
08209.AC0315	81.0	84.0	79.0	10.7	-	-
08209.AC0319	82.0	85.5	80.0	10.5	-	-
08209.AC0323	83.0	86.0	81.0	10.7	-	-

OTHER PLASTICS



Order No.	d ₁	d ₂	d ₃	h ₁	Thread	Thread inch
08209.AC0327	84.0	90.0	82.0	12.0	-	-
08209.AC0329	84.5	90.0	82.0	9.2	-	-
08209.AC0331	85.0	89.0	83.0	11.0	-	-
08209.AC0335	86.0	89.0	83.5	11.0	-	-
08209.AC0339	86.5	90.0	84.0	11.0	-	-
08209.AC0343	87.0	90.0	85.0	10.7	-	-
08209.AC0347	88.0	91.0	86.0	10.5	-	-
08209.AC0351	89.0	92.5	87.0	12.0	-	-
08209.AC0355	90.0	93.5	88.0	11.0	-	-
08209.AC0359	91.0	94.3	89.0	11.0	-	-
08209.AC0363	92.0	95.8	90.0	10.8	-	-
08209.AC0367	93.0	95.6	91.0	10.8	-	-
08209.AC0371	94.0	97.5	92.0	10.7	-	-
08209.AC0375	95.0	97.8	93.0	10.7	-	-
08209.AC0379	96.0	99.5	94.0	10.8	-	-
08209.AC0383	97.0	100.1	95.0	10.7	-	-
08209.AC0387	98.0	101.8	96.0	10.8	-	-
08209.AC0391	99.0	102.5	97.0	10.7	-	-
08209.AC0395	100.0	104.5	98.0	11.5	-	-



Drive Shaft Protection Caps

push-fit

Other Plastics

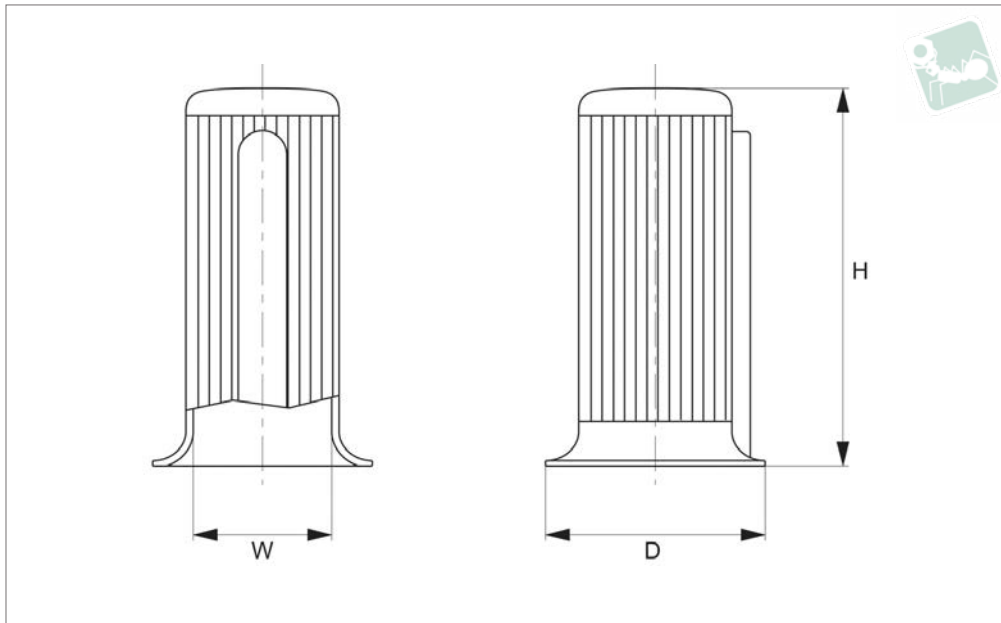

08212.N3

OTHER PLASTICS

Material

Low density polyethylene, yellow.

Important Notes

Sold subject to minimum pack quantity.

Technical Notes

For protection of drive shafts to DIN 748.

Order No.	w	d	h
08212.AC0251	9.0	14.5	24.0
08212.AC0253	11.0	17.5	27.5
08212.AC0255	14.0	22.5	35.0
08212.AC0257	15.0	25.5	32.0
08212.AC0259	16.0	25.5	47.0
08212.AC0261	19.0	30.5	47.0
08212.AC0263	20.0	32.0	58.5
08212.AC0265	22.0	35.5	58.5
08212.AC0267	24.0	38.5	58.5
08212.AC0269	25.0	40.0	70.0
08212.AC0271	28.0	45.0	70.0
08212.AC0273	30.0	48.0	93.5
08212.AC0275	32.0	51.0	93.5
08212.AC0277	35.0	56.0	93.5
08212.AC0279	38.0	61.0	93.5
08212.AC0281	42.0	67.0	127.5
08212.AC0283	45.0	72.0	117.5
08212.AC0285	48.0	77.0	127.5
08212.AC0287	55.0	88.0	127.5
08212.AC0289	60.0	96.0	164.0
08212.AC0291	65.0	104.0	164.0
08212.AC0293	75.0	112.0	164.0

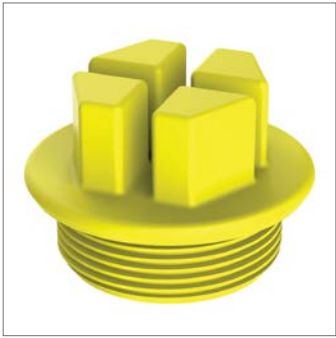

08215.N3

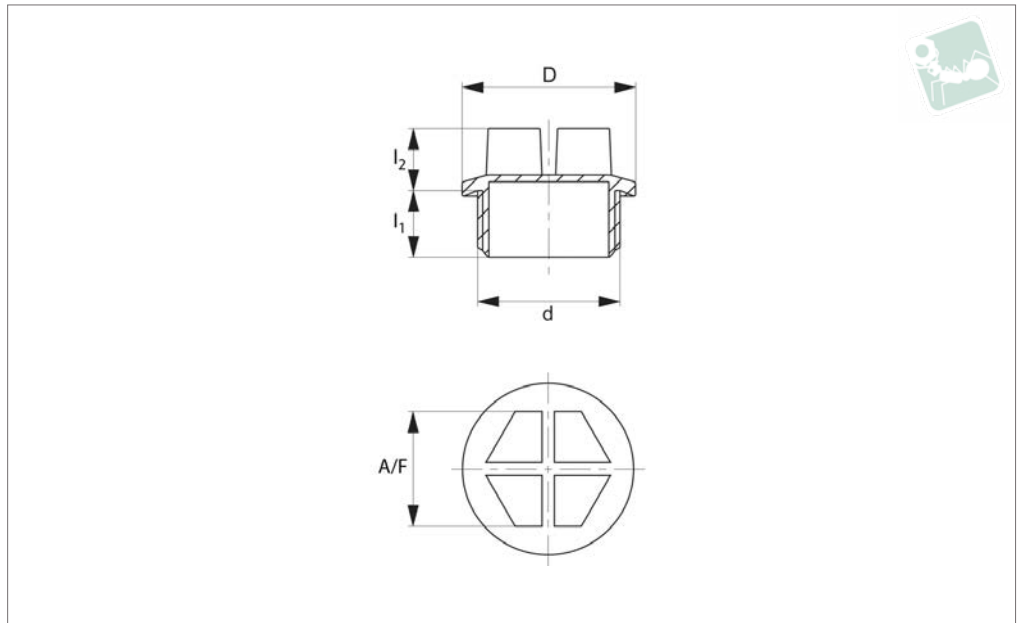

Material
Polyamide, yellow.

spanner.

Technical Notes
Threaded for installation via screwdriver or

Important Notes
Sold subject to minimum pack quantity.

Order No.	d ₁	l ₁	l ₂	A/F	d ₂
08215.AC0881	14,2 - 0,2	7	10	10	M10
08215.AC0883	17,2 - 0,2	10	10	13	M12
08215.AC0885	19,2 - 0,2	10	10	13	M14
08215.AC0887	22,0 - 0,2	10	10	17	M16
08215.AC0889	24,0 - 0,2	10	11	17	M18
08215.AC0891	26,0 - 0,2	10	14	19	M20
08215.AC0893	27,2 - 0,2	10	14	19	M22
08215.AC0895	32,0 - 0,3	13	14	24	M26
08215.AC0897	32,3 - 0,3	13	14	24	M27
08215.AC0899	40,0 - 0,4	13	14	27	M33
08215.AC0901	50,0 - 0,4	13	15	36	M42
08215.AC0949	16.8	9	10	13	1/8"
08215.AC0951	19,0 - 0,2	9	10	13	1/4"
08215.AC0953	22,2 - 0,2	9	11	17	3/8"
08215.AC0955	27,0 - 0,2	12	13	19	1/2"
08215.AC0957	32,3 - 0,3	12	13	24	3/4"
08215.AC0959	40,0 - 0,4	15	14	27	1"
08215.AC0961	50,0 - 0,4	15	15	36	1 1/4"
08215.AC0963	55,4 - 0,4	15	15	41	1 1/2"
08215.AC0965	68.4	15	15	55	2"

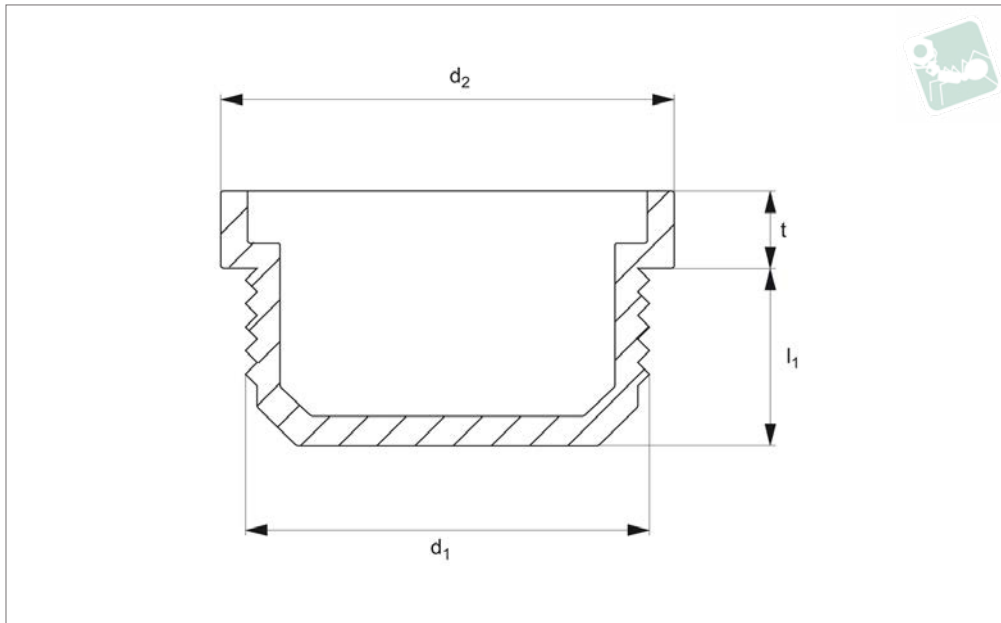

08218.N0

OTHER PLASTICS

Material

Low density polyethylene, red.

Important Notes

Sold subject to minimum pack quantity.

Order No.	d ₁	l ₁	t	d ₂
08218.AC0851	1/4"	7.0	3.5	19.0
08218.AC0853	3/8"	8.5	3.5	22.5
08218.AC0855	1/2"	10.0	4.5	26.0
08218.AC0857	3/4"	11.5	6.0	32.0
08218.AC0859	1"	13.5	6.0	37.0



08221.N3

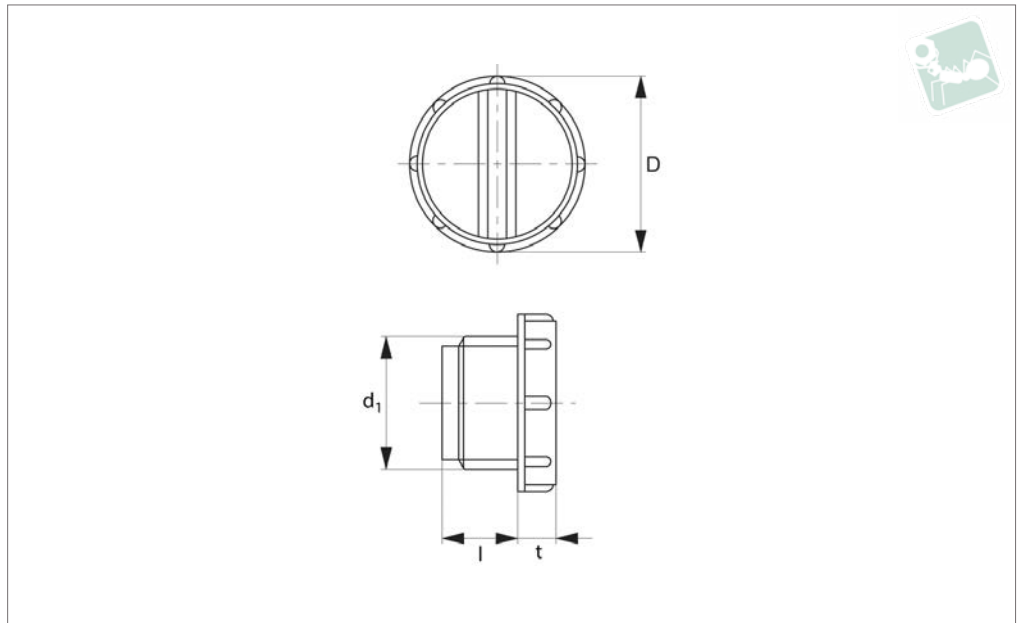

Material

Low density polyethylene, yellow.

Important Notes

Sold subject to minimum pack quantity.

Order No.	d ₁	l	t	d ₂
08221.AC0781	21	9	5	1/8"
08221.AC0783	21	9	5	1/4"
08221.AC0785	23	10	6	3/8"
08221.AC0787	28	12	6	1/2"
08221.AC0801	21	9	5	M12
08221.AC0803	21	9	5	M14
08221.AC0805	23	10	6	M16
08221.AC0807	23	10	6	M18
08221.AC0809	28	12	6	M20
08221.AC0811	28	12	6	M22

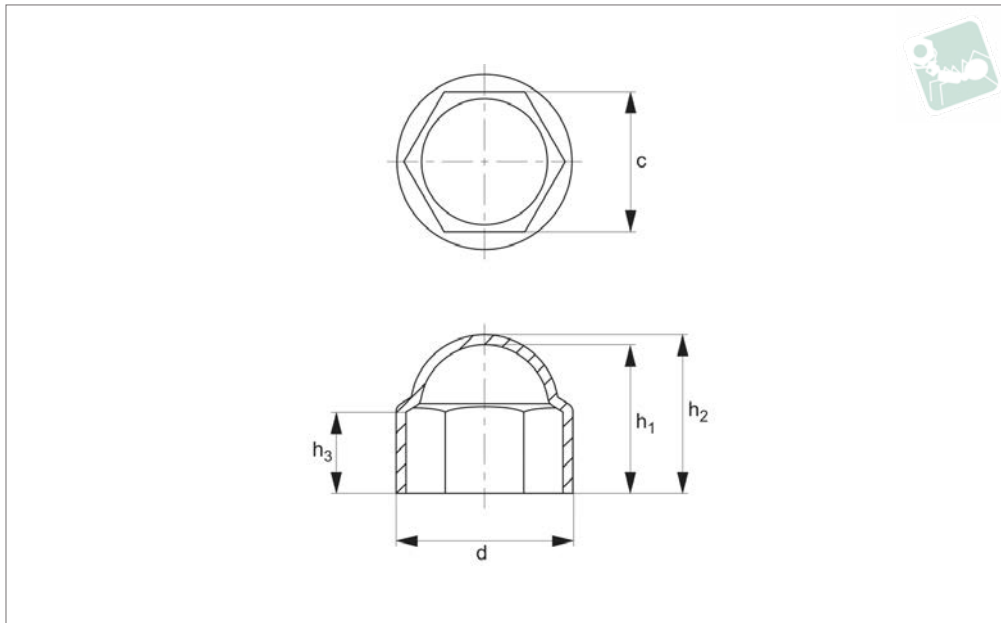

08240.N3

OTHER PLASTICS

Material

Polyethylene, black.

Important Notes

Sold subject to minimum pack quantity.

Order No.	Thread	A/F	c	d	h ₁	h ₂	h ₃
08240.AC0451	M 4	7	6.9	9.0	7.5	8.3	3.5
08240.AC0453	M 5	8	7.9	10.9	8.5	9.3	5.0
08240.AC0455	M 6	10	9.8	12.9	12.0	13.0	6.0
08240.AC0457	M 8	13	12.8	16.8	14.0	15.0	9.0
08240.AC0459	M10	17	16.7	21.3	18.5	19.5	9.0
08240.AC0461	M12	19	18.7	23.6	20.0	21.5	11.0
08240.AC0463	M14	22	21.7	27.5	22.5	24.0	12.0
08240.AC0465	M16	24	23.7	29.8	25.5	27.0	14.0
08240.AC0467	M18	27	26.8	34.0	29.0	43.0	15.0
08240.AC0469	M20	30	29.8	37.7	31.0	33.2	17.0
08240.AC0471	M22	32	31.8	39.7	34.0	36.2	19.0
08240.AC0473	M24	36	35.8	44.4	38.0	39.2	20.0
08240.AC0475	M27	41	40.8	50.1	44.0	46.5	23.0
08240.AC0477	M30	46	45.8	55.9	49.0	51.5	25.0
08240.AC0479	M33	50	49.8	60.5	53.0	55.5	27.0
08240.AC0481	M36	55	54.8	67.0	57.0	59.5	30.0
08240.AC0483	M39	60	59.7	72.0	60.0	62.5	38.0
08240.AC0485	M42	65	63.7	76.5	63.0	65.5	42.0
08240.AC0487	M45	70	69.7	85.5	73.0	75.5	38.0
08240.AC0489	M48	75	75.0	91.6	78.5	81.0	41.0
08240.AC0491	M52	80	80.0	98.0	83.4	86.2	43.5
08240.AC0493	M56	85	85.0	104.2	88.6	91.6	48.0
08240.AC0495	M64	95	95.0	116.7	102.0	105.5	55.0



08250.N7

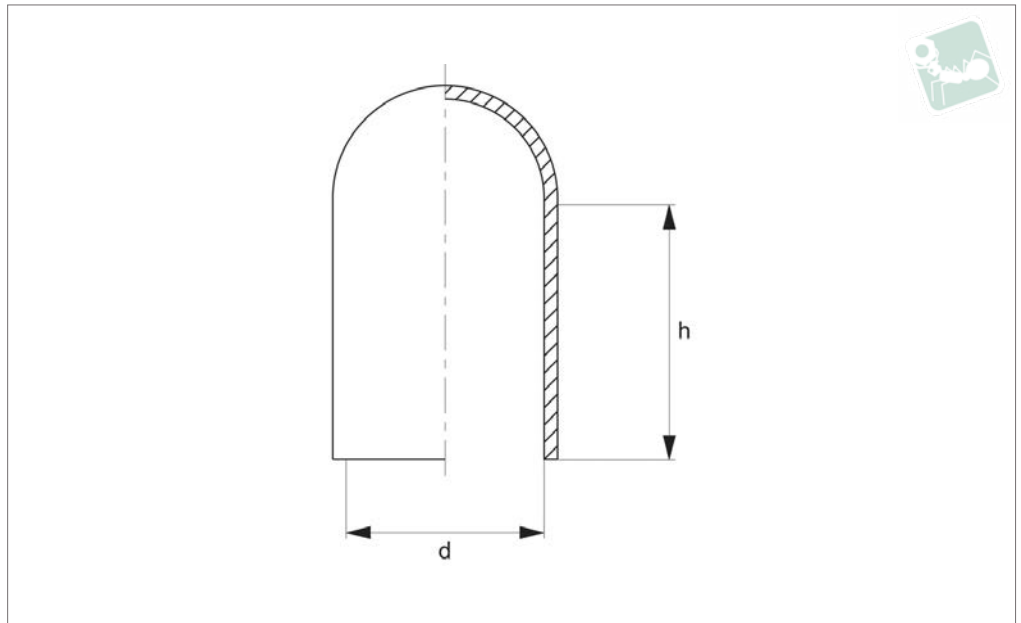

Material

Silicone, natural.
Temperature resistant to +300°C.

of components during powder coating and other finishing processes.

Important Notes

Sold subject to minimum pack quantity.

Technical Notes

To fit on studs, screws or tubes for masking

Order No.	d	h
08250.AC0501	1.8	25.4
08250.AC0503	2.5	25.4
08250.AC0505	3.8	25.4
08250.AC0507	4.6	25.4
08250.AC0509	5.7	38.1
08250.AC0511	7.5	38.1
08250.AC0512	7.9	25.4
08250.AC0513	9.5	25.4
08250.AC0515	11.6	38.1
08250.AC0517	13.6	38.1
08250.AC0519	15.9	38.1
08250.AC0521	19.1	38.1
08250.AC0522	20.6	38.1
08250.AC0523	23.8	38.1



High Temperature Plugs silicone

Other Plastics

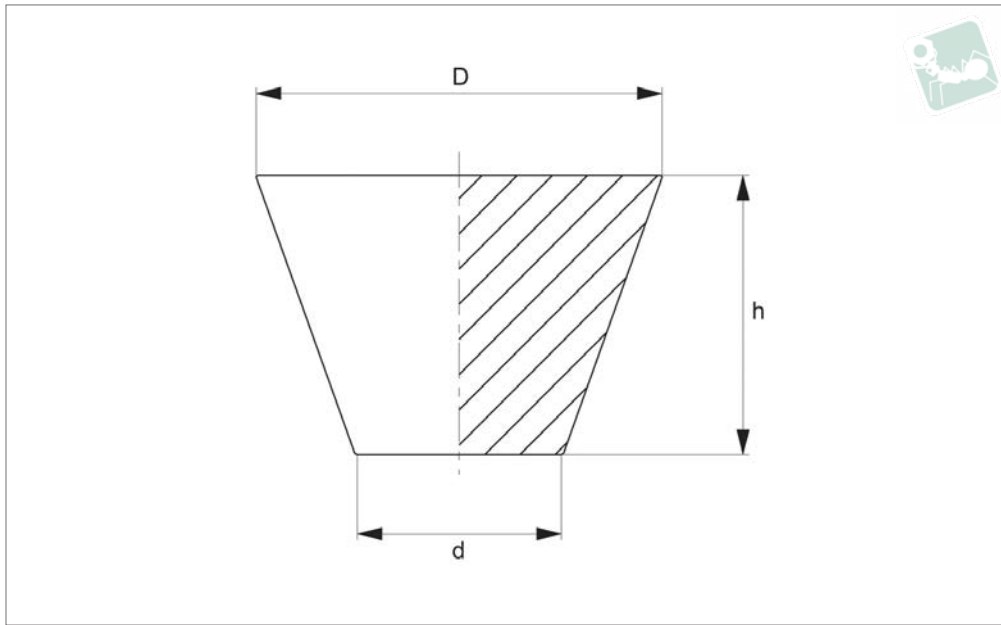

08253.N7

OTHER PLASTICS

Material

Silicone, natural.
Temperature resistant to +300°C.

wide range of finishing processes such as spraying, over painting etc.

Important Notes

Sold subject to minimum pack quantity.

Technical Notes

Plugging of plain or threaded holes for

Order No.	d ₁	h	d ₂
08253.AC0531	0.8	15.9	3.2
08253.AC0533	1.6	15.9	4.8
08253.AC0535	3.2	19.1	6.4
08253.AC0537	4.8	15.9	8.7
08253.AC0539	6.4	19.1	9.5
08253.AC0540	7.9	25.4	14.3
08253.AC0541	8.7	17.5	11.1
08253.AC0543	10.3	25.4	15.1
08253.AC0545	12.7	25.4	16.7
08253.AC0547	14.3	25.4	19.1
08253.AC0549	15.9	25.4	19.8
08253.AC0551	18.3	25.4	23.8
08253.AC0553	19.8	25.4	25.4



08256.N7

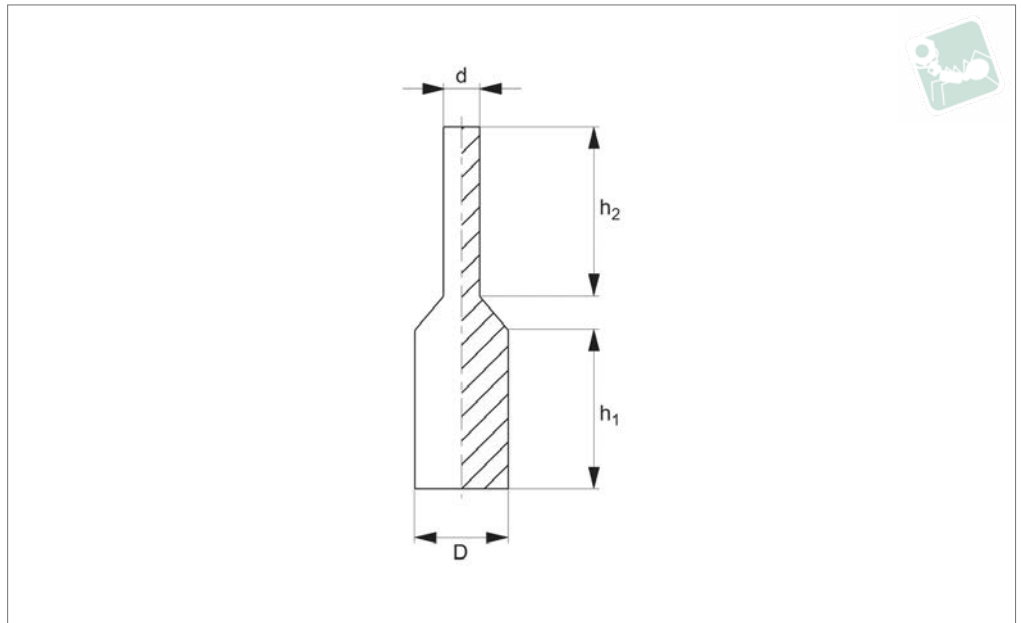

Material

Silicone, natural.
Temperature resistant to +300°C.

out tab improves ease of removal after finishing process.

Important Notes

Sold subject to minimum pack quantity.

Technical Notes

For masking plain or threaded holes. Pull

Order No.	d ₁	d ₂	h ₁	h ₂
08256.AC0102	1.7	1.2	15.9	15.5
08256.AC0106	2.4	1.3	17.8	17.8
08256.AC0114	3.2	1.6	15.9	15.9
08256.AC0122	4.0	1.6	15.9	19.1
08256.AC0124	5.0	2.8	25.4	25.4
08256.AC0130	6.5	3.3	25.4	25.4
08256.AC0132	8.5	3.9	25.4	25.4
08256.AC0138	10.2	4.0	25.4	25.4
08256.AC0140	12.0	6.2	25.4	25.4
08256.AC0142	13.5	6.4	25.4	25.4
08256.AC0146	15.5	6.4	25.4	25.4

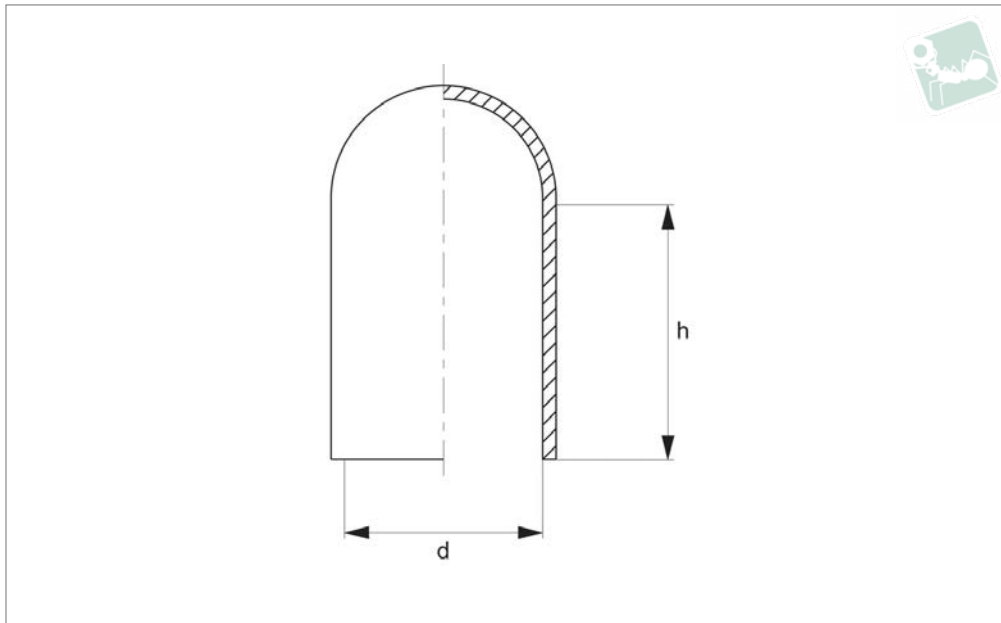

08259.N6

OTHER PLASTICS

Material

EPDM, black.

Temperature resistant to +180°C.

of components during powder coating and other finishing processes.

Important Notes

Sold subject to minimum pack quantity.

Technical Notes

To fit on studs, screws or tubes for masking

Order No.	d	h
08259.AC0621	1.6	19.1
08259.AC0625	2.5	12.7
08259.AC0627	2.8	19.1
08259.AC0629	3.8	19.1
08259.AC0631	3.8	25.4
08259.AC0633	4.0	25.4
08259.AC0635	4.4	25.4
08259.AC0637	4.8	25.4
08259.AC0641	5.7	25.4
08259.AC0643	5.9	25.4
08259.AC0645	7.9	25.4
08259.AC0647	9.5	25.4
08259.AC0649	11.6	25.4
08259.AC0651	13.6	38.1
08259.AC0653	15.9	38.1
08259.AC0655	19.1	38.1
08259.AC0657	20.6	38.1
08259.AC0659	23.8	38.1
08259.AC0661	25.4	38.1



08262.N6

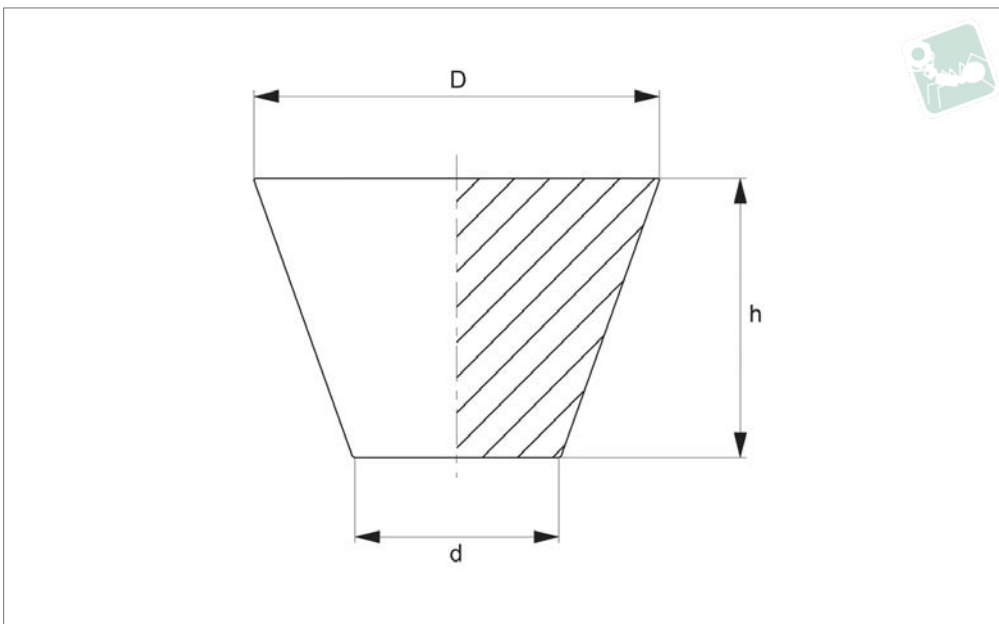

Material

EPDM, black.

Temperature resistant to +180°C.

wide range of finishing processes such as spraying, over painting etc.

Technical Notes

Plugging of plain or threaded holes for

Important Notes

Sold subject to minimum pack quantity.

Order No.	d ₁	h	d ₂
08262.AC0841	0.8	15.9	3.2
08262.AC0843	1.6	15.9	4.8
08262.AC0845	3.2	19.1	6.4
08262.AC0847	4.8	15.9	8.7
08262.AC0849	6.4	19.1	9.5
08262.AC0851	8.7	20.6	11.9
08262.AC0853	10.3	25.4	15.1
08262.AC0855	11.1	25.4	17.5
08262.AC0857	14.3	25.4	19.1
08262.AC0859	15.9	25.4	19.8
08262.AC0861	18.3	25.4	23.8
08262.AC0863	19.8	25.4	25.4



High Temperature Pull Plugs EPDM

Other Plastics

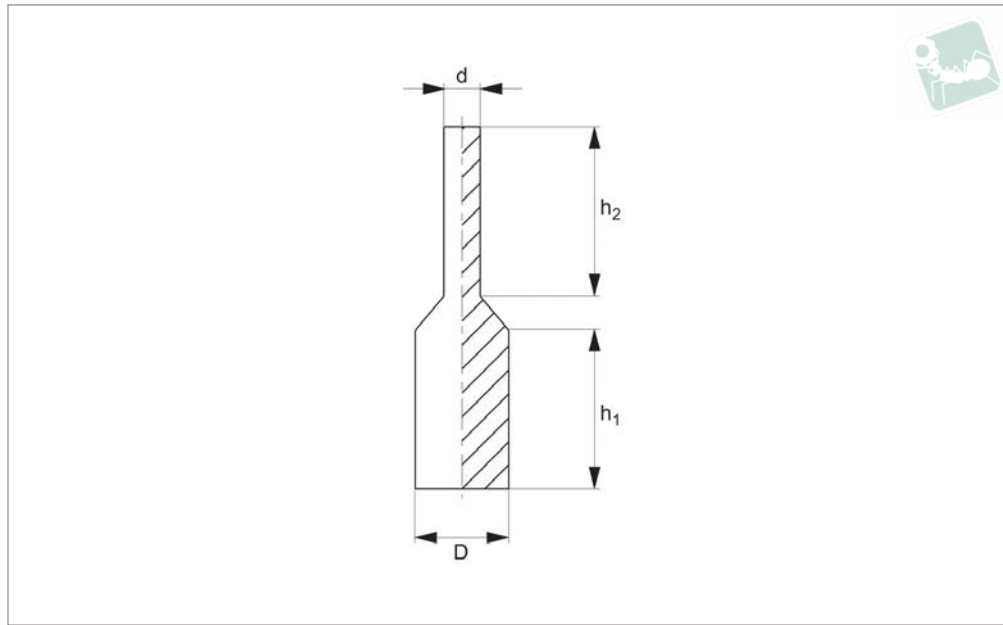

08265.N6

OTHER PLASTICS

Material

EPDM, black.

Temperature resistant to +180°C.

out tab improves ease of removal after finishing process.

Important Notes

Sold subject to minimum pack quantity.

Technical Notes

For masking plain or threaded holes. Pull

Order No.	d ₁	d ₂	h ₁	h ₂
08265.AC0200	1.7	1.2	15.9	15.5
08265.AC0202	2.4	1.3	17.8	17.8
08265.AC0204	3.2	1.6	15.9	15.9
08265.AC0206	4.0	1.6	15.9	19.1
08265.AC0208	5.0	2.8	25.4	25.4
08265.AC0210	6.5	3.3	25.4	25.4
08265.AC0212	8.5	3.9	25.4	25.4
08265.AC0214	10.2	4.0	25.4	25.4
08265.AC0216	12.0	6.2	25.4	25.4
08265.AC0218	13.5	6.4	25.4	25.4
08265.AC0220	15.5	6.4	25.4	25.4

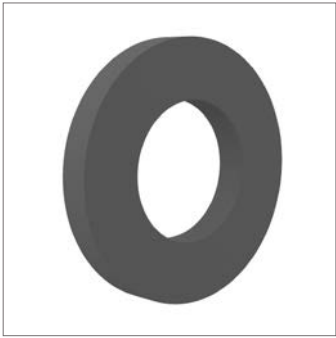

N0412.41N

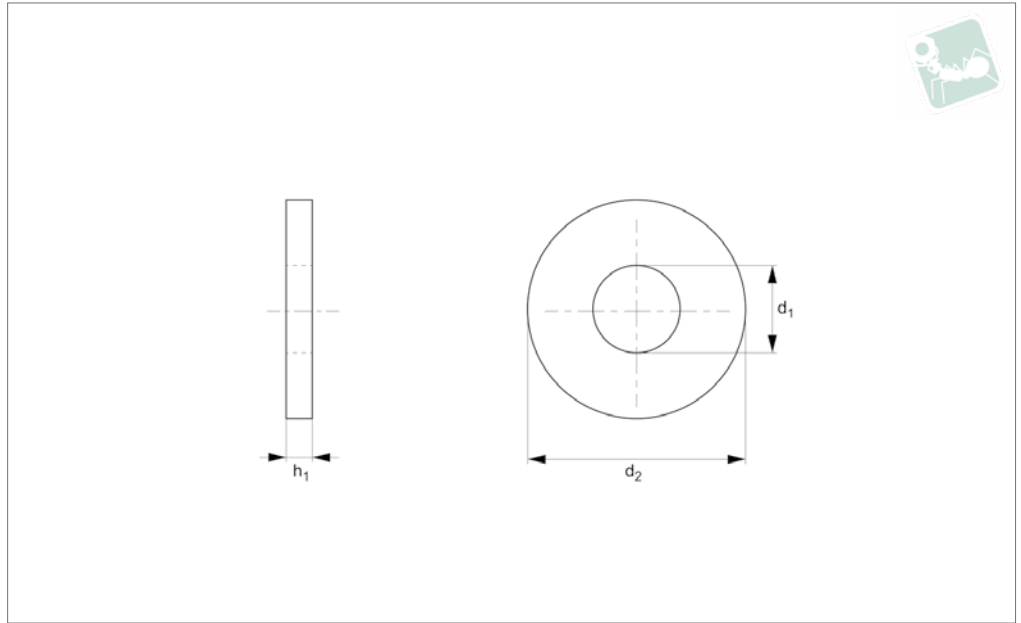

Material
Rubber, black.

Technical Notes
DIN norms were created for metal parts,

the dimensions of our plastic DIN equivalents are close to the norm but do not follow the strict tolerances typically relevant to metal parts.

Order No.	For thread	d ₁	d ₂	h	Material	Grade	Finish	To standard
41N.030.0070.6BD	M 3	3.2	7.0	0.5	Rubber	Std.	Black	DIN 125
41N.040.0090.6BD	M 4	4.3	9.0	0.8	Rubber	Std.	Black	DIN 125
41N.050.0100.6BD	M 5	5.3	10.0	1.0	Rubber	Std.	Black	DIN 125
41N.060.0120.6BD	M 6	6.4	12.0	1.6	Rubber	Std.	Black	DIN 125
41N.080.0160.6BD	M 8	8.4	16.0	1.6	Rubber	Std.	Black	DIN 125
41N.100.0200.6BD	M10	10.5	20.0	2.0	Rubber	Std.	Black	DIN 125
41N.120.0240.6BD	M12	13.0	24.0	2.5	Rubber	Std.	Black	DIN 125
41N.160.0300.6BD	M16	17.0	30.0	3.0	Rubber	Std.	Black	DIN 125
41N.200.0370.6BD	M20	21.0	37.0	3.0	Rubber	Std.	Black	DIN 125

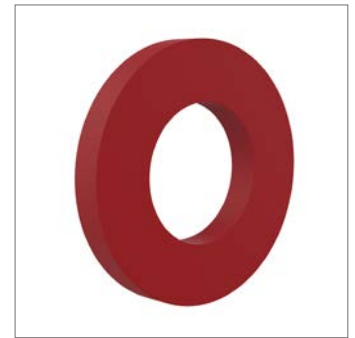
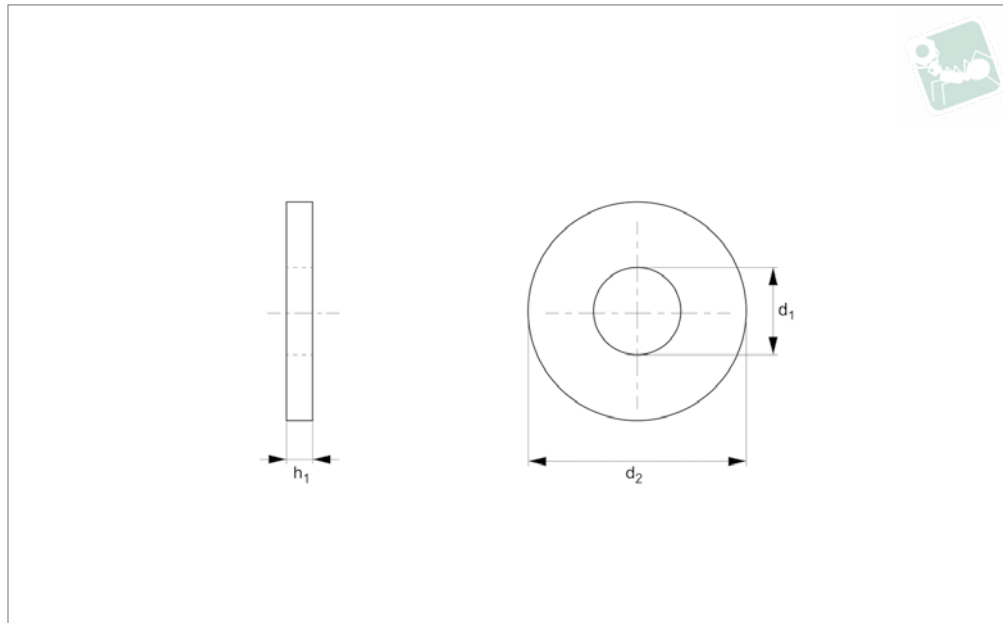

N0409.09N

OTHER PLASTICS

Material
Fibre.

the dimensions of our plastic DIN equivalents are close to the norm but do not follow the strict tolerances typically relevant to metal parts.

Technical Notes

DIN norms were created for metal parts,

Order No.	For thread	d_1	d_2	h	Material	Grade	Finish	To standard
09N.030.0070.8AD	M 3	3.2	7.0	0.5	Fibre	Std.	Red	DIN 125
09N.040.0090.8AD	M 4	4.3	9.0	0.8	Fibre	Std.	Red	DIN 125
09N.050.0100.8AD	M 5	5.3	10.0	1.0	Fibre	Std.	Red	DIN 125
09N.060.0120.8AD	M 6	6.4	12.0	1.6	Fibre	Std.	Red	DIN 125
09N.080.0160.8AD	M 8	8.4	16.0	1.6	Fibre	Std.	Red	DIN 125
09N.100.0200.8AD	M10	10.5	20.0	2.0	Fibre	Std.	Red	DIN 125
09N.120.0240.8AD	M12	13.0	24.0	2.5	Fibre	Std.	Red	DIN 125
09N.160.0300.8AD	M16	17.0	30.0	3.0	Fibre	Std.	Red	DIN 125
09N.200.0370.8AD	M20	21.0	37.0	3.0	Fibre	Std.	Red	DIN 125



M0400.N8

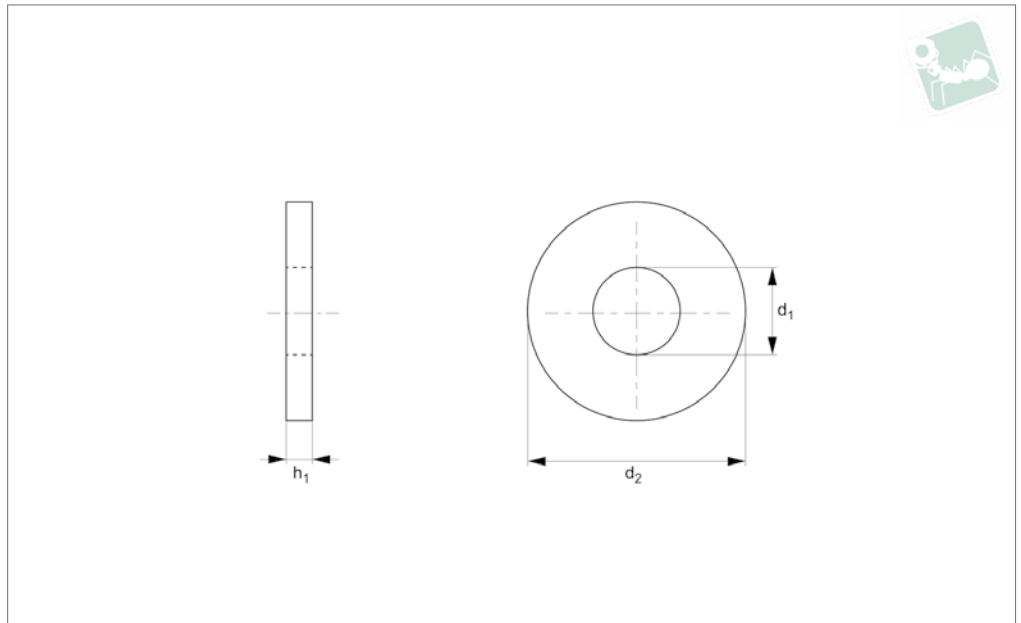

Material
Fibre.

Technical Notes
Fibre flat washer.

Order No.	Dia. Ø nom.	d_1	d_2	h	Material	Finish
M0400.030-005	3	3.2	7.0	0.5	Red Fibre	unfinished
M0400.040-008	4	4.3	9.0	0.8	Red Fibre	unfinished
M0400.040-010	4	4.3	9.0	1.0	Red Fibre	unfinished
M0400.050-010	5	5.3	10.0	1.0	Red Fibre	unfinished
M0400.060-010	6	6.4	12.5	1.0	Red Fibre	unfinished
M0400.080-010	8	8.4	17.0	1.0	Red Fibre	unfinished
M0400.100-010	10	10.5	21.0	1.0	Red Fibre	unfinished
M0400.120-025	12	13.0	24.0	2.5	Red Fibre	unfinished
M0400.160-030	16	17.0	30.0	3.0	Red Fibre	unfinished
M0400.200-030	20	21.0	37.0	3.0	Red Fibre	unfinished



Neoprene Washer

Neoprene

Other Plastics

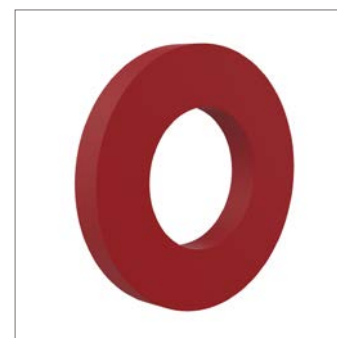
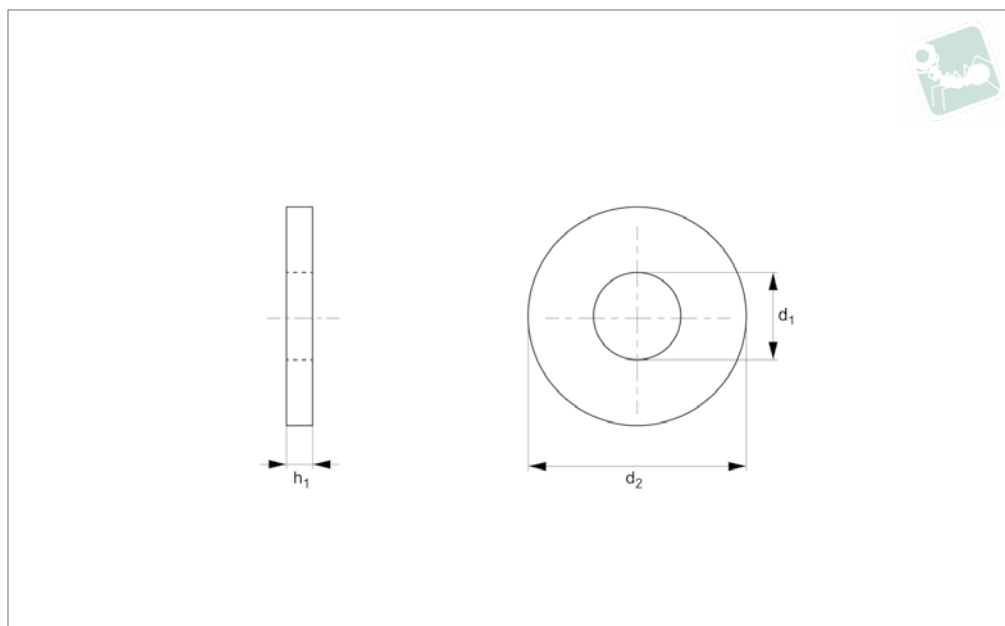

M0409.N9

OTHER PLASTICS

Material
Neoprene.

Technical Notes
Neoprene flat washer.

Order No.	Dia. \emptyset nom.	d_1	d_2	h_1	Material	Finish
M0409.030-005	3	3.2	7.0	0.5	Neoprene	unfinished
M0409.040-010	4	4.3	9.0	1.0	Neoprene	unfinished
M0409.050-010	5	5.3	10.0	1.0	Neoprene	unfinished
M0409.060-010	6	6.4	12.5	1.0	Neoprene	unfinished
M0409.080-015	8	8.4	17.0	1.5	Neoprene	unfinished
M0409.100-015	10	10.5	21.0	1.5	Neoprene	unfinished
M0409.120-020	13	13.0	24.0	2.0	Neoprene	unfinished
M0409.160-020	17	17.0	30.0	2.0	Neoprene	unfinished
M0409.200-030	21	21.0	37.0	3.0	Neoprene	unfinished