

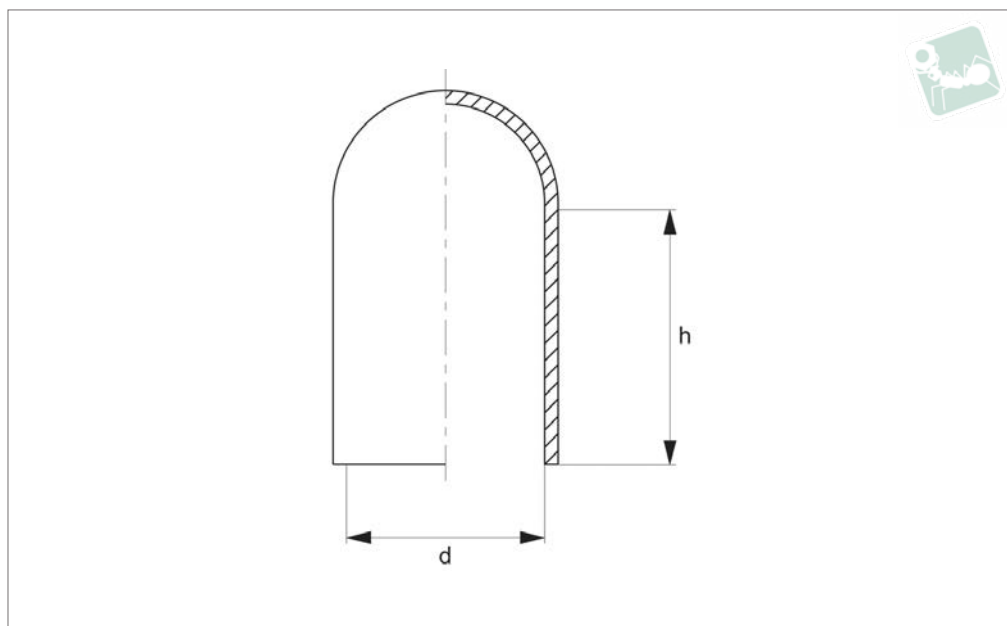

High Temperature Caps silicone

Other Plastics



08250.N7

OTHER PLASTICS

Material

Silicone, natural.
Temperature resistant to +300°C.

of components during powder coating and other finishing processes.

Important Notes

Sold subject to minimum pack quantity.

Technical Notes

To fit on studs, screws or tubes for masking

Order No.	d	h
08250.AC0501	1.8	25.4
08250.AC0503	2.5	25.4
08250.AC0505	3.8	25.4
08250.AC0507	4.6	25.4
08250.AC0509	5.7	38.1
08250.AC0511	7.5	38.1
08250.AC0512	7.9	25.4
08250.AC0513	9.5	25.4
08250.AC0515	11.6	38.1
08250.AC0517	13.6	38.1
08250.AC0519	15.9	38.1
08250.AC0521	19.1	38.1
08250.AC0522	20.6	38.1
08250.AC0523	23.8	38.1



08253.N7

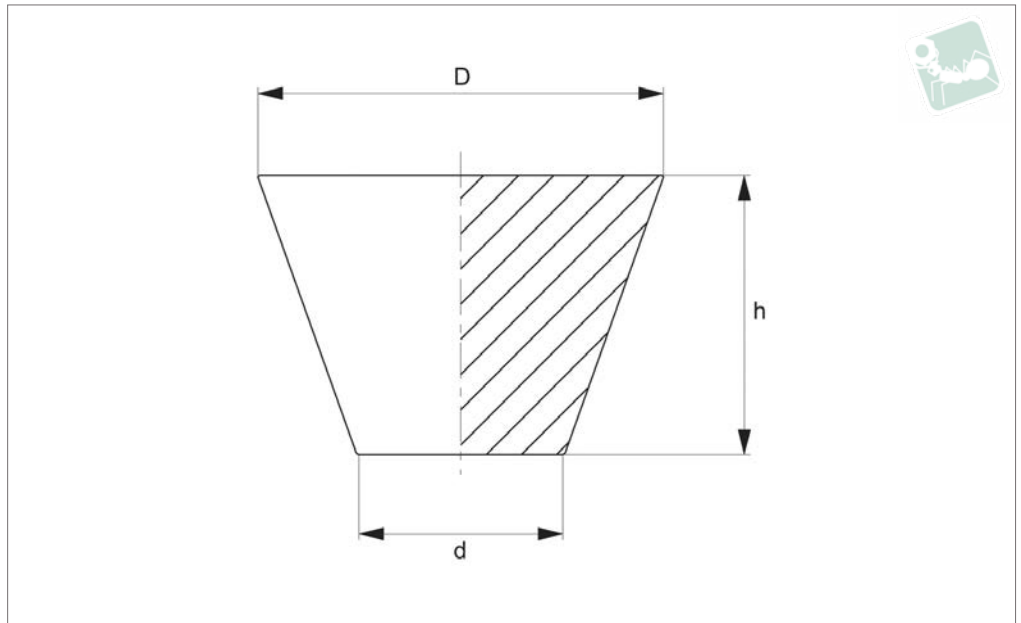

Material

Silicone, natural.
Temperature resistant to +300°C.

wide range of finishing processes such as spraying, over painting etc.

Important Notes

Sold subject to minimum pack quantity.

Technical Notes

Plugging of plain or threaded holes for

Order No.	d ₁	h	d ₂
08253.AC0531	0.8	15.9	3.2
08253.AC0533	1.6	15.9	4.8
08253.AC0535	3.2	19.1	6.4
08253.AC0537	4.8	15.9	8.7
08253.AC0539	6.4	19.1	9.5
08253.AC0540	7.9	25.4	14.3
08253.AC0541	8.7	17.5	11.1
08253.AC0543	10.3	25.4	15.1
08253.AC0545	12.7	25.4	16.7
08253.AC0547	14.3	25.4	19.1
08253.AC0549	15.9	25.4	19.8
08253.AC0551	18.3	25.4	23.8
08253.AC0553	19.8	25.4	25.4



High Temperature Pull Plugs silicone

Other Plastics

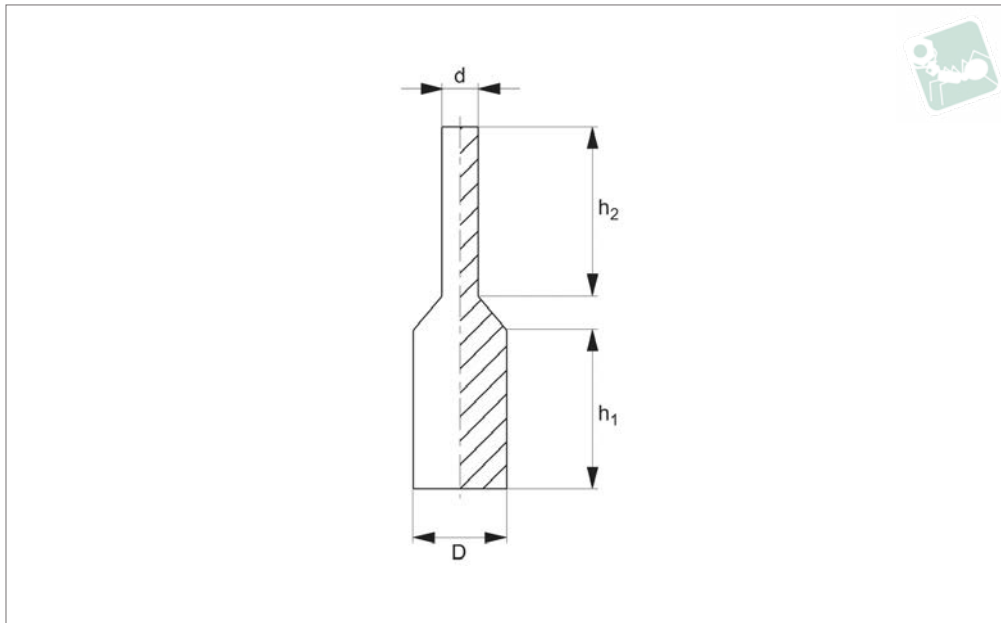

08256.N7

OTHER PLASTICS

Material

Silicone, natural.
Temperature resistant to +300°C.

out tab improves ease of removal after finishing process.

Important Notes

Sold subject to minimum pack quantity.

Technical Notes

For masking plain or threaded holes. Pull

Order No.	d ₁	d ₂	h ₁	h ₂
08256.AC0102	1.7	1.2	15.9	15.5
08256.AC0106	2.4	1.3	17.8	17.8
08256.AC0114	3.2	1.6	15.9	15.9
08256.AC0122	4.0	1.6	15.9	19.1
08256.AC0124	5.0	2.8	25.4	25.4
08256.AC0130	6.5	3.3	25.4	25.4
08256.AC0132	8.5	3.9	25.4	25.4
08256.AC0138	10.2	4.0	25.4	25.4
08256.AC0140	12.0	6.2	25.4	25.4
08256.AC0142	13.5	6.4	25.4	25.4
08256.AC0146	15.5	6.4	25.4	25.4



08259.N6

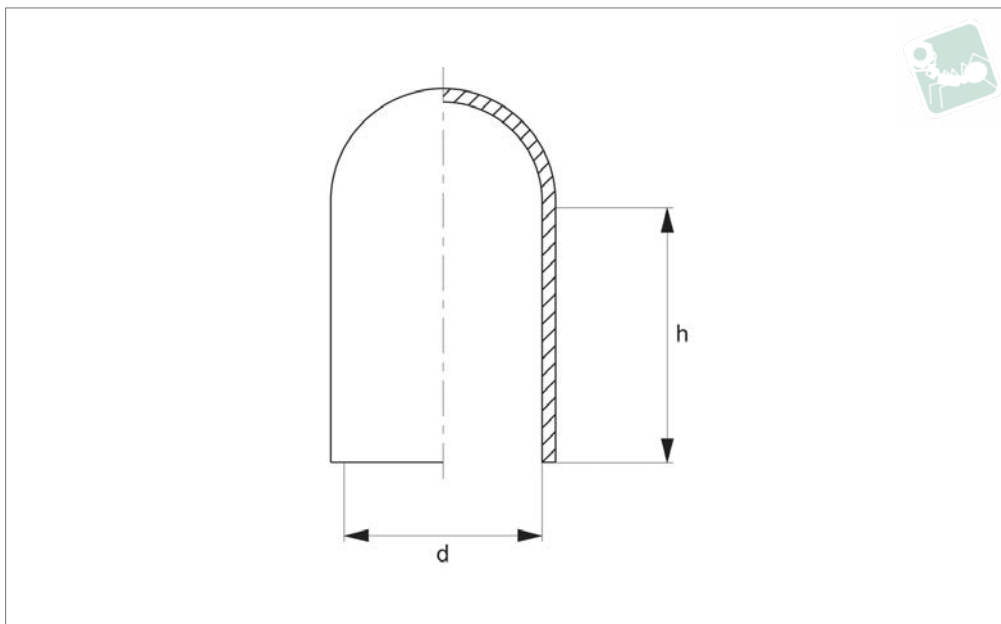

Material

EPDM, black.

Temperature resistant to +180°C.

Technical Notes

To fit on studs, screws or tubes for masking

of components during powder coating and other finishing processes.

Important Notes

Sold subject to minimum pack quantity.

Order No.	d	h
08259.AC0621	1.6	19.1
08259.AC0625	2.5	12.7
08259.AC0627	2.8	19.1
08259.AC0629	3.8	19.1
08259.AC0631	3.8	25.4
08259.AC0633	4.0	25.4
08259.AC0635	4.4	25.4
08259.AC0637	4.8	25.4
08259.AC0641	5.7	25.4
08259.AC0643	5.9	25.4
08259.AC0645	7.9	25.4
08259.AC0647	9.5	25.4
08259.AC0649	11.6	25.4
08259.AC0651	13.6	38.1
08259.AC0653	15.9	38.1
08259.AC0655	19.1	38.1
08259.AC0657	20.6	38.1
08259.AC0659	23.8	38.1
08259.AC0661	25.4	38.1



High Temperature Plugs EPDM

Other Plastics

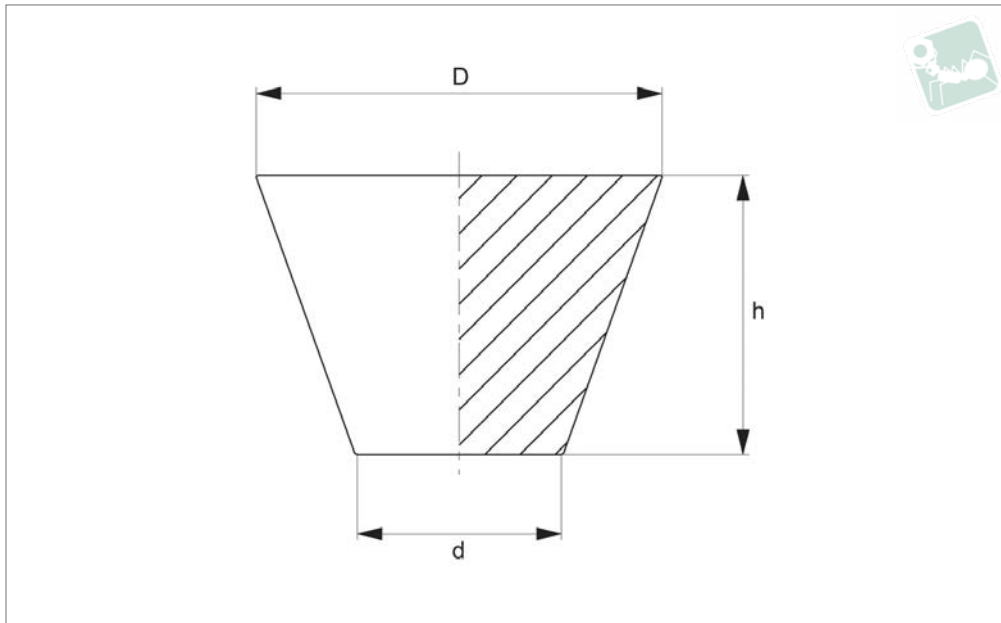

08262.N6

OTHER PLASTICS

Material

EPDM, black.

Temperature resistant to +180°C.

wide range of finishing processes such as spraying, over painting etc.

Technical Notes

Plugging of plain or threaded holes for

Important Notes

Sold subject to minimum pack quantity.

Order No.	d ₁	h	d ₂
08262.AC0841	0.8	15.9	3.2
08262.AC0843	1.6	15.9	4.8
08262.AC0845	3.2	19.1	6.4
08262.AC0847	4.8	15.9	8.7
08262.AC0849	6.4	19.1	9.5
08262.AC0851	8.7	20.6	11.9
08262.AC0853	10.3	25.4	15.1
08262.AC0855	11.1	25.4	17.5
08262.AC0857	14.3	25.4	19.1
08262.AC0859	15.9	25.4	19.8
08262.AC0861	18.3	25.4	23.8
08262.AC0863	19.8	25.4	25.4



08265.N6

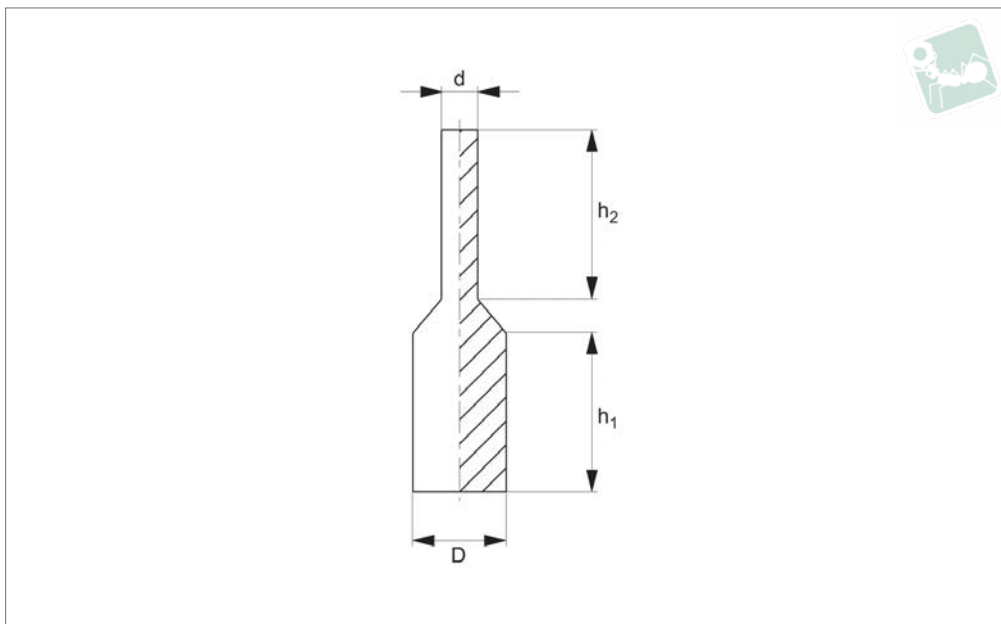

Material

EPDM, black.

Temperature resistant to +180°C.

out tab improves ease of removal after finishing process.

Important Notes

Sold subject to minimum pack quantity.

Technical Notes

For masking plain or threaded holes. Pull

Order No.	d ₁	d ₂	h ₁	h ₂
08265.AC0200	1.7	1.2	15.9	15.5
08265.AC0202	2.4	1.3	17.8	17.8
08265.AC0204	3.2	1.6	15.9	15.9
08265.AC0206	4.0	1.6	15.9	19.1
08265.AC0208	5.0	2.8	25.4	25.4
08265.AC0210	6.5	3.3	25.4	25.4
08265.AC0212	8.5	3.9	25.4	25.4
08265.AC0214	10.2	4.0	25.4	25.4
08265.AC0216	12.0	6.2	25.4	25.4
08265.AC0218	13.5	6.4	25.4	25.4
08265.AC0220	15.5	6.4	25.4	25.4