

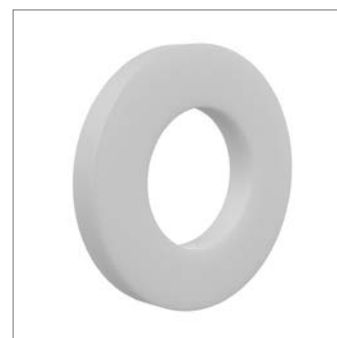

A Plain Washers

Form A, DIN 125 A

Polypropylene

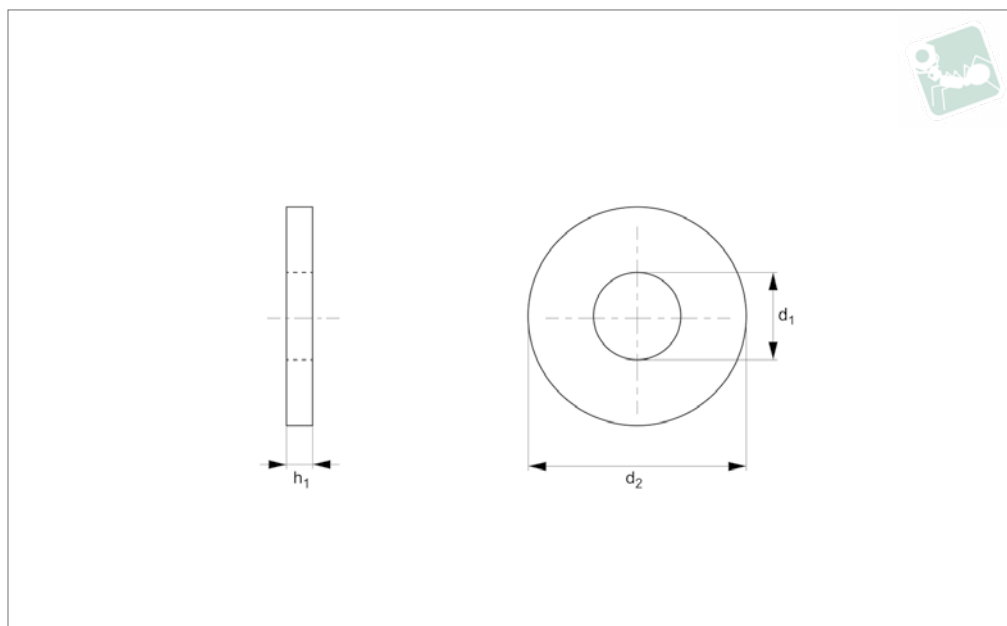

P0330.N2

POLYPROPYLENE

Material

Polypropylene.

To DIN 125 A.

Technical Notes

Polypropylene washers - form A.

Order No.	For thread	d_1	d_2	h	Material
P0330.020-N2	M 2	2.2	5	0.3	Polypropylene
P0330.022-N2	M2-5	2.2	5	0.3	Polypropylene
P0330.023-N2	M2,3	2.5	6	0.5	Polypropylene
P0330.025-N2	M2,5	2.7	6	0.5	Polypropylene
P0330.027-N2	M2,5	2.7	6	0.5	Polypropylene
P0330.030-N2	M 3	3.2	7	0.5	Polypropylene
P0330.032-N2	M3	3.2	7	0.5	Polypropylene
P0330.035-N2	M3,5	3.7	8	0.5	Polypropylene
P0330.037-N2	M3,5	3.7	8	0.5	Polypropylene
P0330.040-N2	M 4	4.3	9	0.8	Polypropylene
P0330.043-N2	M4-5	4.3	9	0.8	Polypropylene
P0330.050-N2	M 5	5.3	10	1.0	Polypropylene
P0330.053-N2	M5-3	5.3	10	1.0	Polypropylene
P0330.060-N2	M 6	6.4	12	1.6	Polypropylene
P0330.064-N2	M 6	6.4	12	1.6	Polypropylene
P0330.074-N2	M7-9	7.4	14	1.6	Polypropylene
P0330.080-N2	M 8	8.4	16	1.6	Polypropylene
P0330.084-N2	M8-5	8.4	16	1.6	Polypropylene
P0330.100-N2	M10	10.5	20	2.0	Polypropylene
P0330.250-N2	M24	25	44	4.0	Polypropylene

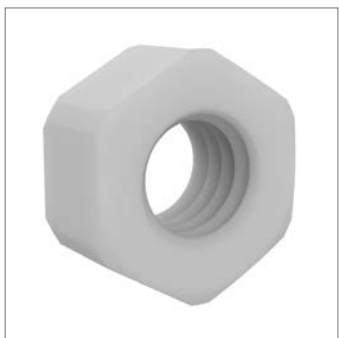

P0500.N2

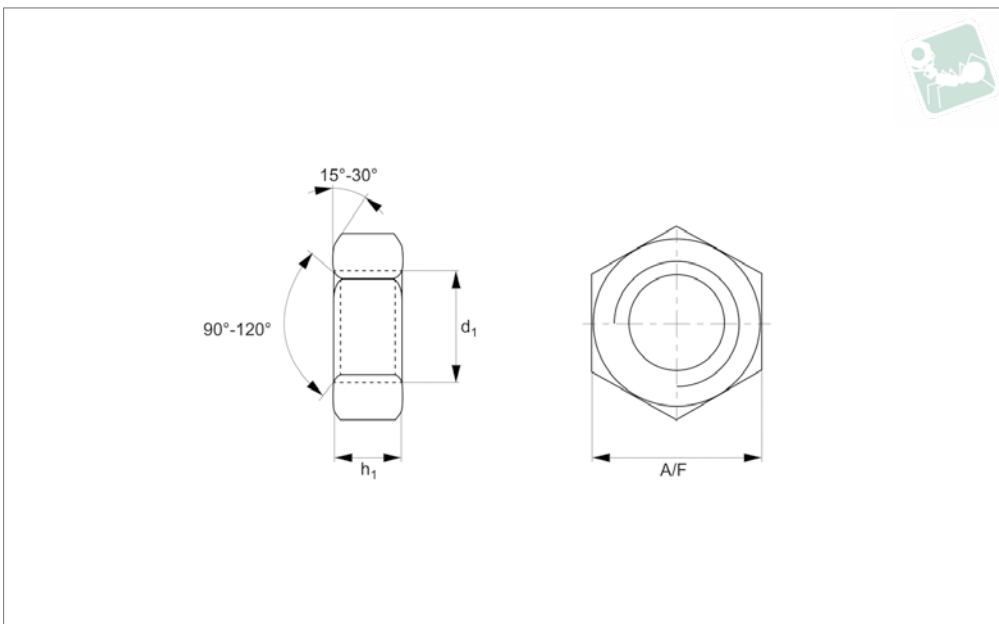

Material

Polypropylene.

To DIN 934. Standard metric coarse pitch threads.

Technical Notes

Polypropylene full nut

Order No.	d ₁	h ₁ min.	A/F	Material	Finish
P0500.040	M 4	3.2	7.0	Polypropylene	unfinished
P0500.050	M 5	4.0	8.0	Polypropylene	unfinished
P0500.060	M 6	5.0	10	Polypropylene	unfinished
P0500.080	M 8	6.5	13	Polypropylene	unfinished
P0500.100	M10	8.0	17	Polypropylene	unfinished
P0500.120	M12	10	19	Polypropylene	unfinished
P0500.160	M16	13	24	Polypropylene	unfinished
P0500.200	M20	16	30	Polypropylene	unfinished
P0500.240	M24	19	36	Polypropylene	unfinished



Slotted Csk Head Screws

Slotted csk, DIN 963

Polypropylene

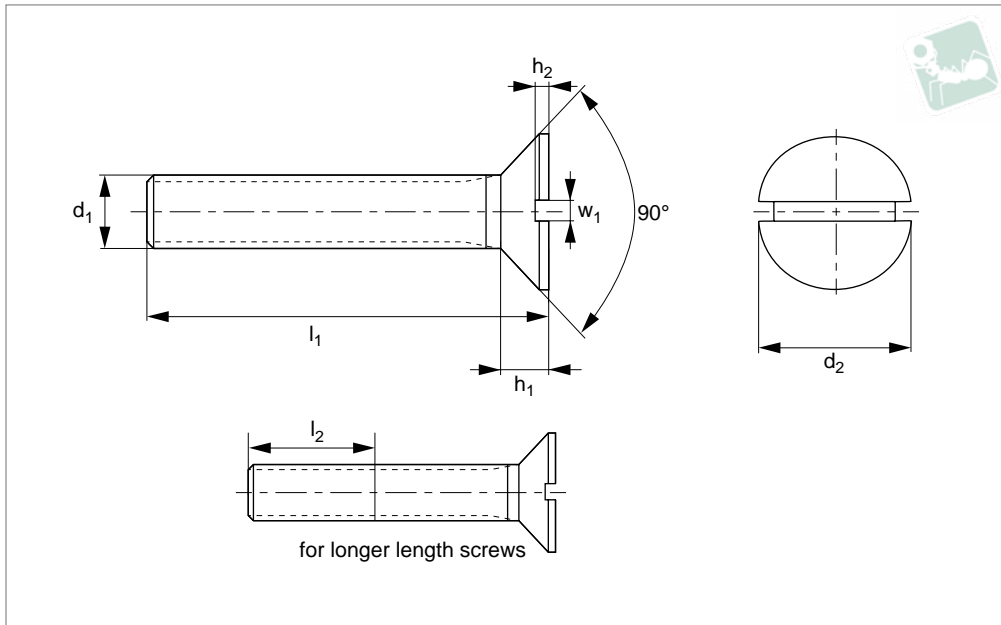

P0013.N2

POLYPROPYLENE

Material
Polypropylene.

Technical Notes

To DIN 963, ISO 2009. For the majority of

screw lengths, the thread goes all the way to the head of the screw (i.e. $l_1 = l_2$) less 2.5 thread pitches. For longer length screws, the threaded portion $l_1 > l_2$.

See technical page for tightening torques.

Order No.	d_1	l_1	d_2	l_2	h_1	w_1	Material	Finish
P0013.060-010	M 6	10	11.0	1.2	3	1.6	Polypropylene	unfinished
P0013.060-015	M 6	15	11.0	1.2	3	1.6	Polypropylene	unfinished
P0013.060-020	M 6	20	11.0	1.2	3	1.6	Polypropylene	unfinished
P0013.080-010	M 8	10	14.5	1.6	4	2.0	Polypropylene	unfinished
P0013.080-015	M 8	15	14.5	1.6	4	2.0	Polypropylene	unfinished
P0013.080-020	M 8	20	14.5	1.6	4	2.0	Polypropylene	unfinished
P0013.080-025	M 8	25	14.5	1.6	4	2.0	Polypropylene	unfinished
P0013.100-015	M 10	15	18.0	2.0	5	2.5	Polypropylene	unfinished
P0013.100-020	M 10	20	18.0	2.0	5	2.5	Polypropylene	unfinished
P0013.100-025	M 10	25	18.0	2.0	5	2.5	Polypropylene	unfinished
P0013.100-030	M 10	30	18.0	2.0	5	2.5	Polypropylene	unfinished

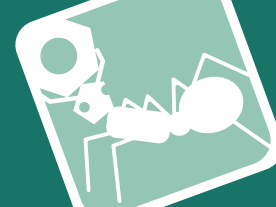

P0001.N2

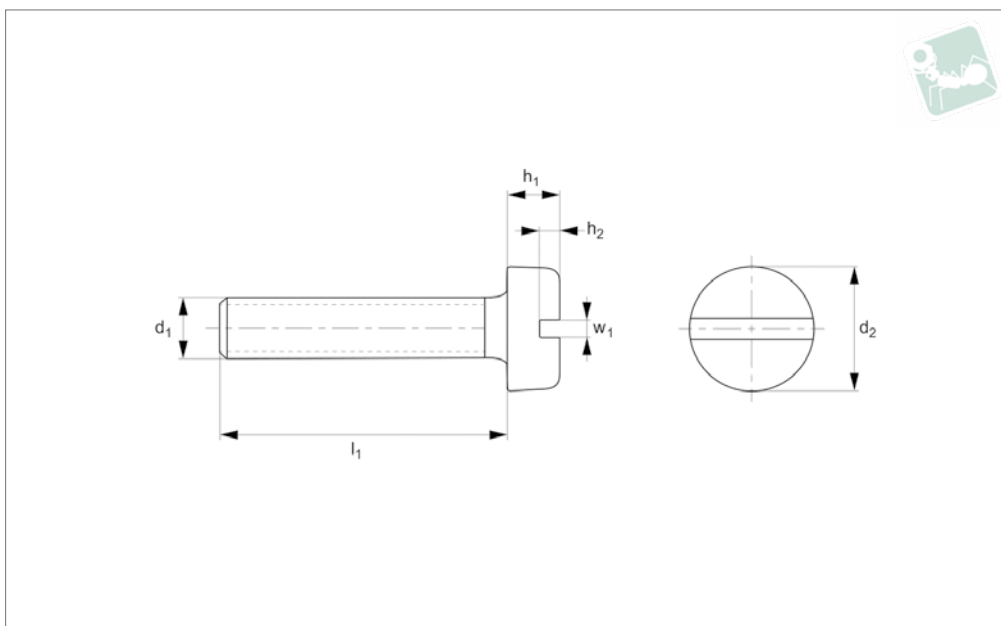

Material

Polypropylene.

Technical Notes

Polypropylene slotted cheese head.
To DIN 84.

Order No.	d ₁	d ₂	h ₁	h ₂	l	w	Material	Finish
P0001.050-012	M 5	8.5	3.3	1.30	12	1.20	Polypropylene	unfinished
P0001.050-016	M 5	8.5	3.3	1.30	16	1.20	Polypropylene	unfinished
P0001.050-020	M 5	8.5	3.3	1.30	20	1.20	Polypropylene	unfinished
P0001.060-010	M 6	10.0	3.9	1.60	10	1.60	Polypropylene	unfinished
P0001.060-012	M 6	10.0	3.9	1.60	12	1.60	Polypropylene	unfinished
P0001.060-016	M 6	10.0	3.9	1.60	16	1.60	Polypropylene	unfinished
P0001.060-020	M 6	10.0	3.9	1.60	20	1.60	Polypropylene	unfinished
P0001.060-025	M 6	10.0	3.9	1.60	25	1.60	Polypropylene	unfinished
P0001.060-030	M 6	10.0	3.9	1.60	30	1.60	Polypropylene	unfinished
P0001.060-040	M 6	10.0	3.9	1.60	40	1.60	Polypropylene	unfinished
P0001.060-045	M 6	10.0	3.9	1.60	45	1.60	Polypropylene	unfinished
P0001.060-050	M 6	10.0	3.9	1.60	50	1.60	Polypropylene	unfinished
P0001.060-055	M 6	10.0	3.9	1.60	55	1.60	Polypropylene	unfinished
P0001.060-060	M 6	10.0	3.9	1.60	60	1.60	Polypropylene	unfinished
P0001.060-065	M 6	10.0	3.9	1.60	65	1.60	Polypropylene	unfinished
P0001.060-070	M 6	10.0	3.9	1.60	70	1.60	Polypropylene	unfinished
P0001.060-075	M 6	10.0	3.9	1.60	75	1.60	Polypropylene	unfinished
P0001.060-080	M 6	10.0	3.9	1.60	80	1.60	Polypropylene	unfinished
P0001.080-020	M 8	13.0	5.0	2.00	20	2.00	Polypropylene	unfinished
P0001.080-025	M 8	13.0	5.0	2.00	25	2.00	Polypropylene	unfinished
P0001.080-030	M 8	13.0	5.0	2.00	30	2.00	Polypropylene	unfinished
P0001.080-035	M 8	13.0	5.0	2.00	35	2.00	Polypropylene	unfinished
P0001.080-040	M 8	13.0	5.0	2.00	40	2.00	Polypropylene	unfinished
P0001.080-050	M 8	13.0	5.0	2.00	50	2.00	Polypropylene	unfinished
P0001.080-060	M 8	13.0	5.0	2.00	60	2.00	Polypropylene	unfinished
P0001.080-065	M 8	13.0	5.0	2.00	65	2.00	Polypropylene	unfinished
P0001.080-070	M 8	13.0	5.0	2.00	70	2.00	Polypropylene	unfinished
P0001.080-075	M 8	13.0	5.0	2.00	75	2.00	Polypropylene	unfinished
P0001.080-080	M 8	13.0	5.0	2.00	80	2.00	Polypropylene	unfinished
P0001.100-020	M10	16.0	6.0	2.40	20	2.50	Polypropylene	unfinished
P0001.100-030	M10	16.0	6.0	2.40	30	2.50	Polypropylene	unfinished
P0001.100-035	M10	16.0	6.0	2.40	35	2.50	Polypropylene	unfinished
P0001.100-040	M10	16.0	6.0	2.40	40	2.50	Polypropylene	unfinished
P0001.100-045	M10	16.0	6.0	2.40	45	2.50	Polypropylene	unfinished
P0001.100-050	M10	16.0	6.0	2.40	50	2.50	Polypropylene	unfinished



Slotted Cheese Head Screws

Slotted cheese head, DIN 84

Polypropylene

Order No.	d ₁	d ₂	h ₁	h ₂	l	w	Material	Finish
P0001.100-055	M10	16.0	6.0	2.40	55	2.50	Polypropylene	unfinished
P0001.100-060	M10	16.0	6.0	2.40	60	2.50	Polypropylene	unfinished

POLYPROPYLENE

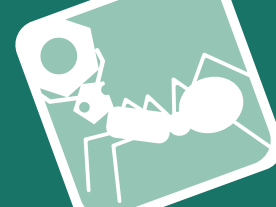

P0010.N2

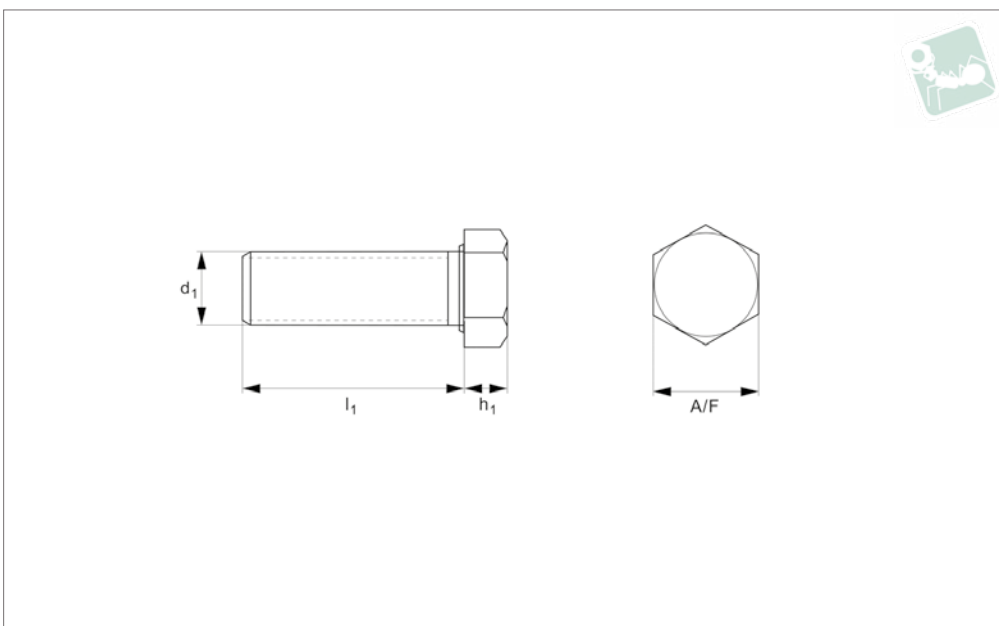

Material

Polypropylene.

up to head.

Technical Notes

Polypropylene hex. head bolts with thread

To DIN 933, ISO 4017.

Order No.	d ₁	l ₁	h ₁	A/F	Material	Finish
P0010.050-012	M 5	12	3.8	8.71	Polypropylene	unfinished
P0010.050-016	M 5	16	3.8	8.71	Polypropylene	unfinished
P0010.050-020	M 5	20	3.8	8.71	Polypropylene	unfinished
P0010.060-010	M 6	10	4.7	10.95	Polypropylene	unfinished
P0010.060-016	M 6	16	4.7	10.95	Polypropylene	unfinished
P0010.060-020	M 6	20	4.7	10.95	Polypropylene	unfinished
P0010.060-025	M 6	25	4.7	10.95	Polypropylene	unfinished
P0010.060-030	M 6	30	4.7	10.95	Polypropylene	unfinished
P0010.060-035	M 6	35	4.7	10.95	Polypropylene	unfinished
P0010.060-040	M 6	40	4.7	10.95	Polypropylene	unfinished
P0010.060-045	M 6	45	4.7	10.95	Polypropylene	unfinished
P0010.060-050	M 6	50	4.7	10.95	Polypropylene	unfinished
P0010.060-055	M 6	55	4.7	10.95	Polypropylene	unfinished
P0010.060-060	M 6	60	4.7	10.95	Polypropylene	unfinished
P0010.060-065	M 6	65	4.7	10.95	Polypropylene	unfinished
P0010.060-070	M 6	70	4.7	10.95	Polypropylene	unfinished
P0010.060-075	M 6	75	4.7	10.95	Polypropylene	unfinished
P0010.060-080	M 6	80	4.7	10.95	Polypropylene	unfinished
P0010.080-020	M 8	20	6.0	14.26	Polypropylene	unfinished
P0010.080-025	M 8	25	6.0	14.26	Polypropylene	unfinished
P0010.080-030	M 8	30	6.0	14.26	Polypropylene	unfinished
P0010.080-035	M 8	35	6.0	14.26	Polypropylene	unfinished
P0010.080-040	M 8	40	6.0	14.26	Polypropylene	unfinished
P0010.080-045	M 8	45	6.0	14.26	Polypropylene	unfinished
P0010.080-050	M 8	50	6.0	14.26	Polypropylene	unfinished
P0010.080-060	M 8	60	6.0	14.26	Polypropylene	unfinished
P0010.080-065	M 8	65	6.0	14.26	Polypropylene	unfinished
P0010.080-070	M 8	70	6.0	14.26	Polypropylene	unfinished
P0010.080-075	M 8	75	6.0	14.26	Polypropylene	unfinished
P0010.080-080	M 8	80	6.0	14.26	Polypropylene	unfinished
P0010.100-020	M10	20	7.5	17.62	Polypropylene	unfinished
P0010.100-025	M10	25	7.5	17.62	Polypropylene	unfinished
P0010.100-030	M10	30	7.5	17.62	Polypropylene	unfinished
P0010.100-035	M10	35	7.5	17.62	Polypropylene	unfinished



Hexagon Head Bolts

with thread up to head, DIN 933

Polypropylene

Order No.	d ₁	l ₁	h ₁	A/F	Material	Finish
P0010.100-040	M10	40	7.5	17.62	Polypropylene	unfinished
P0010.100-045	M10	45	7.5	17.62	Polypropylene	unfinished
P0010.100-050	M10	50	7.5	17.62	Polypropylene	unfinished
P0010.100-055	M10	55	7.5	17.62	Polypropylene	unfinished
P0010.100-060	M10	60	7.5	17.62	Polypropylene	unfinished
P0010.100-065	M10	65	7.5	17.62	Polypropylene	unfinished
P0010.100-070	M10	70	7.5	17.62	Polypropylene	unfinished
P0010.100-075	M10	75	7.5	17.62	Polypropylene	unfinished
P0010.100-080	M10	80	7.5	17.62	Polypropylene	unfinished
P0010.100-085	M10	85	7.5	17.62	Polypropylene	unfinished
P0010.100-090	M10	90	7.5	17.62	Polypropylene	unfinished
P0010.100-095	M10	95	7.5	17.62	Polypropylene	unfinished
P0010.100-100	M10	100	7.5	17.62	Polypropylene	unfinished
P0010.120-020	M12	20	9.0	19.86	Polypropylene	unfinished
P0010.120-025	M12	25	9.0	19.86	Polypropylene	unfinished
P0010.120-030	M12	30	9.0	19.86	Polypropylene	unfinished
P0010.120-035	M12	35	9.0	19.86	Polypropylene	unfinished
P0010.120-040	M12	40	9.0	19.86	Polypropylene	unfinished
P0010.120-045	M12	45	9.0	19.86	Polypropylene	unfinished
P0010.120-050	M12	50	9.0	19.86	Polypropylene	unfinished
P0010.120-055	M12	55	9.0	19.86	Polypropylene	unfinished
P0010.120-060	M12	60	9.0	19.86	Polypropylene	unfinished
P0010.120-065	M12	65	9.0	19.86	Polypropylene	unfinished
P0010.120-070	M12	70	9.0	19.86	Polypropylene	unfinished
P0010.120-075	M12	75	9.0	19.86	Polypropylene	unfinished
P0010.120-080	M12	80	9.0	19.86	Polypropylene	unfinished
P0010.120-090	M12	90	9.0	19.86	Polypropylene	unfinished
P0010.120-100	M12	100	9.0	19.86	Polypropylene	unfinished
P0010.120-110	M12	110	9.0	19.86	Polypropylene	unfinished
P0010.120-120	M12	120	9.0	19.86	Polypropylene	unfinished
P0010.120-130	M12	130	9.0	19.86	Polypropylene	unfinished
P0010.120-140	M12	140	9.0	19.86	Polypropylene	unfinished
P0010.120-150	M12	150	9.0	19.86	Polypropylene	unfinished
P0010.160-020	M16	20	10.0	24.00	Polypropylene	unfinished
P0010.160-025	M16	25	10.0	24.00	Polypropylene	unfinished
P0010.160-030	M16	30	10.0	24.00	Polypropylene	unfinished
P0010.160-035	M16	35	10.0	24.00	Polypropylene	unfinished
P0010.160-040	M16	40	10.0	24.00	Polypropylene	unfinished
P0010.160-045	M16	45	10.0	24.00	Polypropylene	unfinished
P0010.160-050	M16	50	10.0	24.00	Polypropylene	unfinished
P0010.160-055	M16	55	10.0	24.00	Polypropylene	unfinished
P0010.160-060	M16	60	10.0	24.00	Polypropylene	unfinished
P0010.160-065	M16	65	10.0	24.00	Polypropylene	unfinished
P0010.160-070	M16	70	10.0	24.00	Polypropylene	unfinished
P0010.160-075	M16	75	10.0	24.00	Polypropylene	unfinished
P0010.160-085	M16	85	10.0	24.00	Polypropylene	unfinished

POLYPROPYLENE