

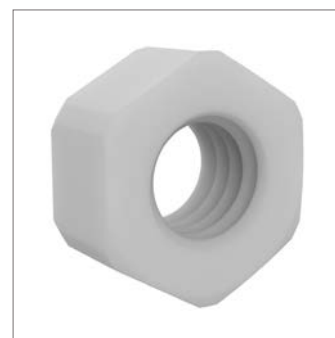

Full Nuts

Full nuts, DIN 934

Polypropylene

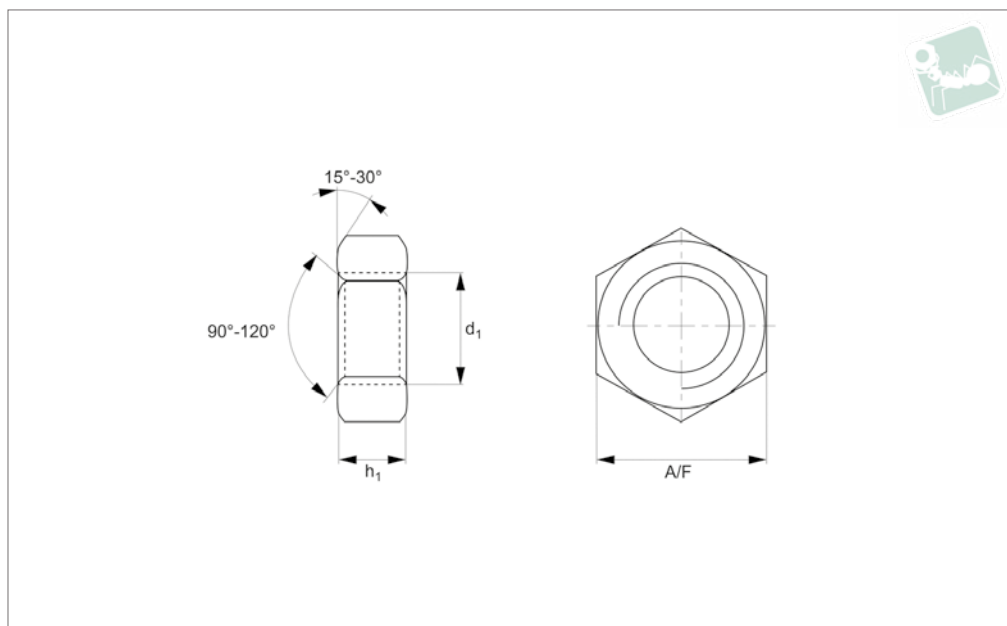

P0500.N2

POLYPROPYLENE

Material

Polypropylene.

To DIN 934. Standard metric coarse pitch threads.

Technical Notes

Polypropylene full nut

Order No.	d_1	h_1 min.	A/F	Material	Finish
P0500.040	M 4	3.2	7.0	Polypropylene	unfinished
P0500.050	M 5	4.0	8.0	Polypropylene	unfinished
P0500.060	M 6	5.0	10	Polypropylene	unfinished
P0500.080	M 8	6.5	13	Polypropylene	unfinished
P0500.100	M10	8.0	17	Polypropylene	unfinished
P0500.120	M12	10	19	Polypropylene	unfinished
P0500.160	M16	13	24	Polypropylene	unfinished
P0500.200	M20	16	30	Polypropylene	unfinished
P0500.240	M24	19	36	Polypropylene	unfinished