

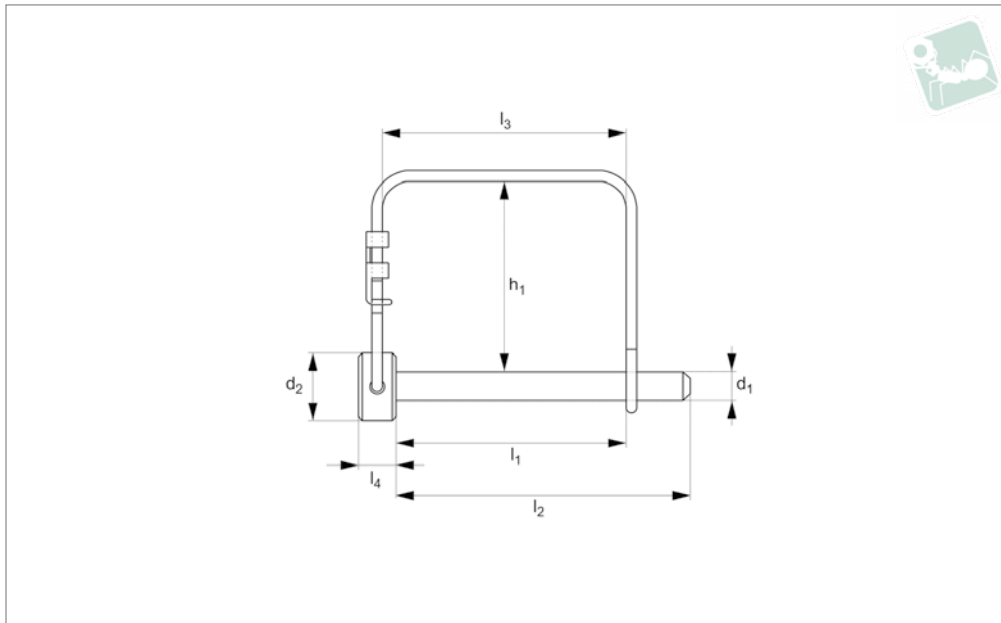

Lock Pin - Square Wire - Double steel or stainless steel

Pull Pins



PP1700

PULL PINS

Material

Pin: Carbon steel, C1008-C1010, zinc plated. Or stainless steel AISI 304.
Double wire loop: hard drawn spring wire.

parts. Pull wire over pin to lock in place, no need for separate clevis pin and cotter. Ideal economic solution for quick release applications.

permanently attach wire lock pin to assembly, see part nos. L to LA1224. Also known as PTO Pins, Snapper Pins, Hitch Pins and Quick Pins.

Technical Notes

Pin and cotter in one, preventing loss of

Tips

Use lanyard or retaining cable to

Order No.	Material	d ₁ inch	d ₁ mm	l ₁ inch	l ₁ mm	d ₂	h ₁	l ₂	l ₃	l ₄
PP1700.025-225-C	Zinc Plated Steel	(1/4")	6.35	(2-1/4")	57.15	14.3	41.3	63.5	52.4	7.9
PP1700.025-250-C	Zinc Plated Steel	(1/4")	6.35	(2-1/2")	63.50	14.3	44.5	69.9	60.3	7.9
PP1700.025-300-C	Zinc Plated Steel	(1/4")	6.35	(3")	76.20	14.3	42.9	82.6	80.4	7.9
PP1700.031-225-C	Zinc Plated Steel	(5/16")	7.94	(2-1/4")	57.15	15.9	39.7	63.5	52.4	7.9
PP1700.031-250-C	Zinc Plated Steel	(5/16")	7.94	(2-1/2")	63.50	15.9	42.9	69.9	60.3	7.9
PP1700.031-300-C	Zinc Plated Steel	(5/16")	7.94	(3")	76.20	15.9	42.9	82.6	80.4	7.9
PP1700.031-363-C	Zinc Plated Steel	(5/16")	7.94	(3-9/16")	90.49	15.9	41.3	101.6	91.3	7.9
PP1700.031-406-C	Zinc Plated Steel	(5/16")	7.94	(4-1/16")	103.19	15.9	41.3	114.3	103.9	7.9
PP1700.037-225-C	Zinc Plated Steel	(3/8")	9.53	(2-1/4")	57.15	15.9	38.1	63.5	52.4	7.9
PP1700.037-250-C	Zinc Plated Steel	(3/8")	9.53	(2-1/2")	63.50	15.9	41.3	69.9	60.3	7.9
PP1700.037-300-C	Zinc Plated Steel	(3/8")	9.53	(3")	76.20	15.9	41.3	82.6	80.4	7.9
PP1700.037-363-C	Zinc Plated Steel	(3/8")	9.53	(3-9/16")	90.49	15.9	41.3	101.6	91.3	7.9
PP1700.037-406-C	Zinc Plated Steel	(3/8")	9.53	(4-1/16")	103.10	15.9	41.3	114.3	103.9	7.9
PP1700.025-225-S	Stainless Steel	(1/4")	6.35	(2-1/4")	57.15	14.3	41.3	63.5	52.4	7.9
PP1700.025-250-S	Stainless Steel	(1/4")	6.35	(2-1/2")	63.50	14.3	44.5	69.9	60.3	7.9
PP1700.031-225-S	Stainless Steel	(5/16")	7.94	(2-1/4")	57.15	15.9	39.7	63.5	52.4	7.9
PP1700.031-250-S	Stainless Steel	(5/16")	7.94	(2-1/2")	63.50	15.9	42.9	69.9	60.3	7.9
PP1700.031-300-S	Stainless Steel	(5/16")	7.94	(3")	76.20	15.9	42.9	82.6	80.4	7.9
PP1700.037-225-S	Stainless Steel	(3/8")	9.53	(2-1/4")	57.15	15.9	38.1	63.5	52.4	7.9
PP1700.037-250-S	Stainless Steel	(3/8")	9.53	(2-1/2")	63.50	15.9	41.3	69.9	60.3	7.9
PP1700.037-300-S	Stainless Steel	(3/8")	9.53	(3")	76.20	15.9	41.3	82.6	80.4	7.9



PP1702

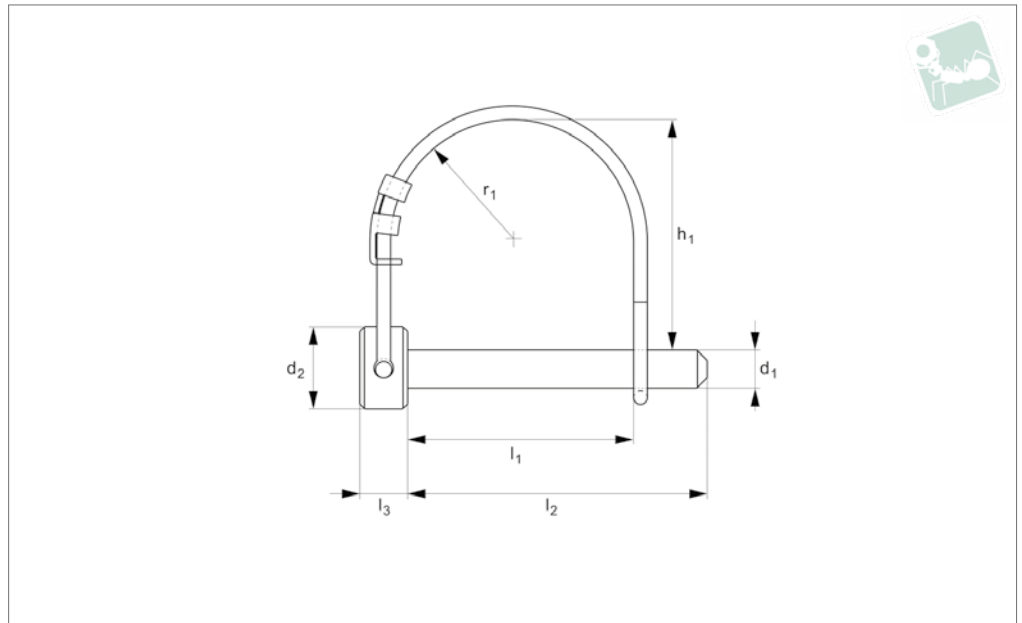

Material

Pin: Carbon steel, C1008-C1010, zinc plated. Or stainless steel AISI 304.
Double wire loop: hard drawn spring wire.

parts. Pull wire over pin to lock in place, no need for separate clevis pin and cotter. Ideal economic solution for quick release applications.

permanently attach wire lock pin to assembly, see part nos. L to LA1224. Also known as PTO Pins, Snapper Pins, Hitch Pins and Quick Pins.

Technical Notes

Pin and cotter in one, preventing loss of

Tips

Use lanyard or retaining cable to

Order No.	Material	d ₁	l ₁	d ₂	h	l ₂	l ₃	R
PP1702.025-138-C	Zinc Plated steel	6,35 (1/4")	35,05 (1 3/8")	14,22	41,40	41,40	7,87	17,53
PP1702.025-175-C	Zinc Plated steel	6,35 (1/4")	44,45 (1 3/4")	14,22	39,62	50,80	7,87	20,57
PP1702.025-250-C	Zinc Plated steel	6,35 (1/4")	63,5 (2 1/2")	14,22	44,45	69,85	7,87	30,23
PP1702.031-138-C	Zinc Plated steel	7,87 (5/16")	35,05 (1 3/8")	16,00	39,62	41,40	7,87	17,53
PP1702.031-175-C	Zinc Plated steel	7,87 (5/16")	44,45 (1 3/4")	16,00	38,10	50,80	7,87	20,57
PP1702.031-280-C	Zinc Plated steel	7,87 (5/16")	71,12 (2 1/2")	16,00	42,93	69,85	7,87	30,23
PP1702.037-138-C	Zinc Plated steel	9,65 (3/8")	35,05 (1 3/8")	16,00	38,10	41,40	7,87	17,53
PP1702.037-175-C	Zinc Plated steel	9,65 (3/8")	44,45 (1 3/4")	16,00	36,58	50,80	7,87	20,57
PP1702.037-250-C	Zinc Plated steel	9,65 (3/8")	63,5 (2 1/2")	16,00	41,40	69,85	7,87	30,23
PP1702.025-138-S	Stainless steel	6,35 (1/4")	35,05 (1 3/8")	14,22	41,40	41,40	7,87	17,53
PP1702.025-175-S	Stainless steel	6,35 (1/4")	44,45 (1 3/4")	14,22	39,62	50,80	7,87	20,57
PP1702.031-138-S	Stainless steel	7,87 (5/16")	35,05 (1 3/8")	16,00	39,62	41,40	7,87	17,53
PP1702.031-175-S	Stainless steel	7,87 (5/16")	44,45 (1 3/4")	16,00	38,10	50,80	7,87	20,57
PP1702.037-138-S	Stainless steel	9,65 (3/8")	35,05 (1 3/8")	16,00	38,10	41,40	7,87	17,53
PP1702.037-175-S	Stainless steel	9,65 (3/8")	44,45 (1 3/4")	16,00	36,58	50,80	7,87	20,57



Lock Pin - Round Wire - Tab Pin

steel or stainless steel

Pull Pins

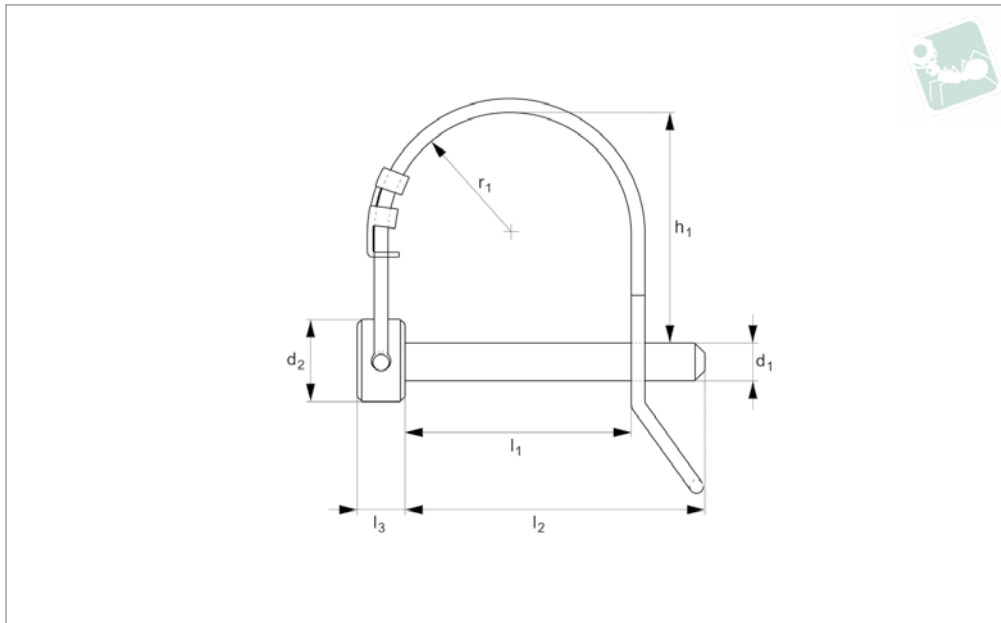

PP1704

PULL PINS

Material

Pin: Carbon steel, C1008-C1010, zinc plated. Or stainless steel AISI 304.
Wire loop: hard drawn spring wire.

Technical Notes

Pin and cotter in one, preventing loss of parts. Even easier to use than standard

wire lock pins, the formed "tab" enable easy locking an unlocking. Ideal economic solution for quick release applications.

Push down tab to engage with pin and "lock", pull up tab to release. Tab guides wire loop into locked position, acting as a

load ramp.

Tips

Use lanyard or retaining cable to permanently attach wire lock pin to assembly, see part nos. L to LA1224.

Order No.	Material	d ₁	l ₁	d ₂	h	l ₂	l ₃	R
PP1704.025-175-C	Zinc plated steel	6,35 (1/4")	44,45 (1 3/4")	14,22	39,62	58,67	7,87	20,57
PP1704.031-175-C	Zinc plated steel	7,87 (5/16")	44,45 (1 3/4")	16,00	38,10	58,67	7,87	20,57
PP1704.037-175-C	Zinc plated steel	9,65 (3/8")	44,45 (1 3/4")	16,00	36,58	58,67	7,87	20,57
PP1704.031-250-C	Zinc plated steel	7,87 (5/16")	63,5 (2 1/2")	16,00	44,45	69,85	7,87	20,57
PP1704.037-250-C	Zinc plated steel	9,65 (3/8")	63,5 (2 1/2")	16,00	44,45	69,85	7,87	20,57
PP1704.025-175-S	Stainless steel	6,35 (1/4")	44,45 (1 3/4")	14,22	39,62	58,67	7,87	20,57
PP1704.031-175-S	Stainless steel	7,87 (5/16")	44,45 (1 3/4")	16,00	38,10	58,67	7,87	20,57
PP1704.037-175-S	Stainless steel	9,65 (3/8")	44,45 (1 3/4")	16,00	36,58	58,67	7,87	20,57
PP1704.031-250-S	Stainless steel	7,87 (5/16")	63,5 (2 1/2")	16,00	44,45	69,85	7,87	20,57
PP1704.037-250-S	Stainless steel	9,65 (3/8")	63,5 (2 1/2")	16,00	44,45	69,85	7,87	20,57



PP1706

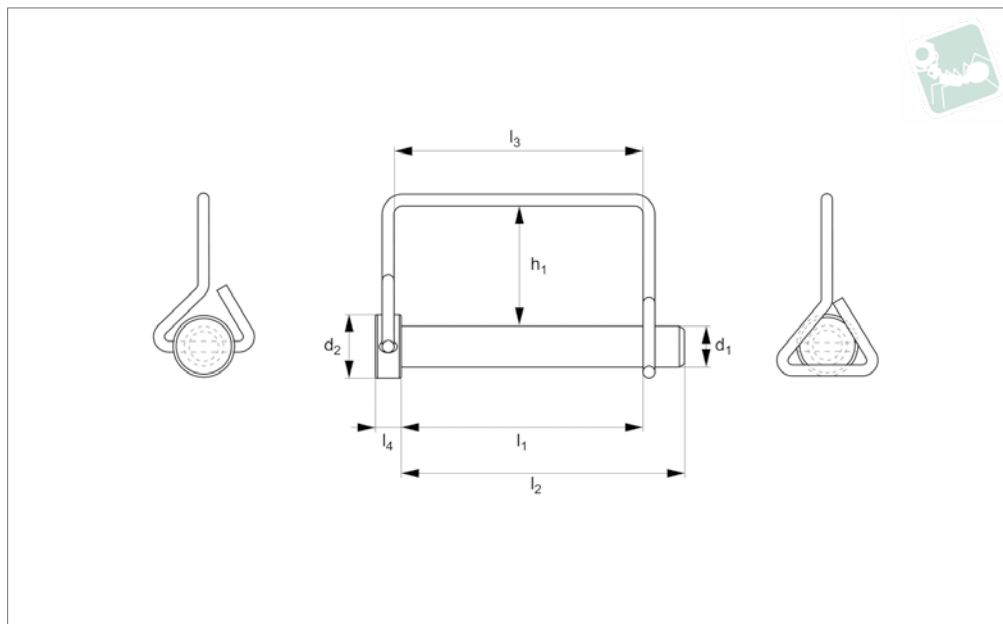

Material

Pin: Carbon steel, C1008-C1010, zinc plated.
 Single wire loop: hard drawn spring wire.

Technical Notes

Pin and cotter in one, preventing loss of

parts. Pull wire over pin to lock in place, no need for separate clevis pin and cotter. Ideal economic solution for quick release applications. Whereas part PP1700 has a double wire loop, PP1706 has just a single wire loop.

Tips

Use lanyard or retaining cable to permanently attach wire lock pin to assembly, see part nos. L to LA1224. Also known as PTO Pins, Snapper Pins, Hitch Pins and Quick Pins.

Order No.	d ₁	l ₁	d ₂	h ₁	l ₂	l ₃	l ₄
PP1706.050-300-C	12,7(1/2")	78,59(3")	19.05	41.3	88.9	78.59	7.94



Lock Pin - Snap Lock - Square Wire with shoulder - steel

Pull Pins

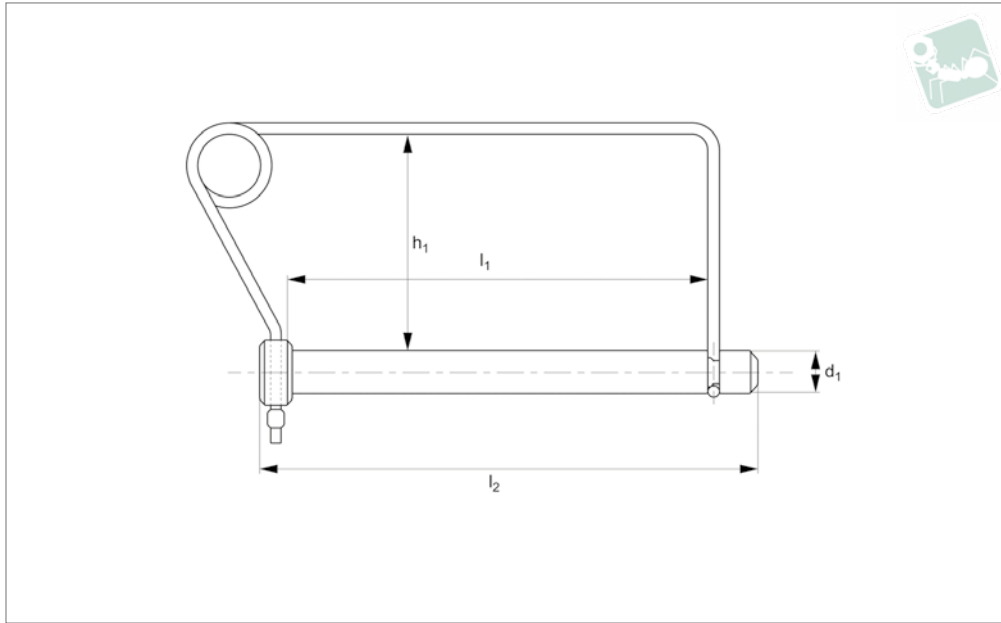

PP1708

PULL PINS

Material

Pin: Carbon steel, C1008-C1010, zinc plated.
Single wire loop: hard drawn spring wire.

parts. Spring wire loop snaps into groove on pin end to provide secure location. Pin has a formed shoulder, l₁ is effective grip length of pin.

permanently attach wire lock pin to assembly, see part nos. L to LA1224.

Technical Notes

Pin and cotter in one, preventing loss of

Tips

Use lanyard or retaining cable to

Order No.	d	l ₁	h	l ₂
PP1708.025-300-C	6,35(1/4")	76,2(3")	38.10	93.73
PP1708.025-350-C	6,35(1/4")	88,9(3 1/2")	44.45	106.43
PP1708.025-400-C	6,35(1/4")	101,6(4")	50.80	119.13
PP1708.031-300-C	7,87(5/16")	76,2(3")	38.10	93.73
PP1708.031-350-C	7,87(5/16")	88,9(3 1/2")	44.45	81.03
PP1708.031-400-C	7,87(5/16")	101,6(4")	50.80	119.13
PP1708.037-300-C	9,65(3/8")	76,2(3")	38.10	93.73
PP1708.037-350-C	9,65(3/8")	88,9(3 1/2")	44.45	106.43
PP1708.037-400-C	9,65(3/8")	101,6(4")	50.80	119.13



PP1710

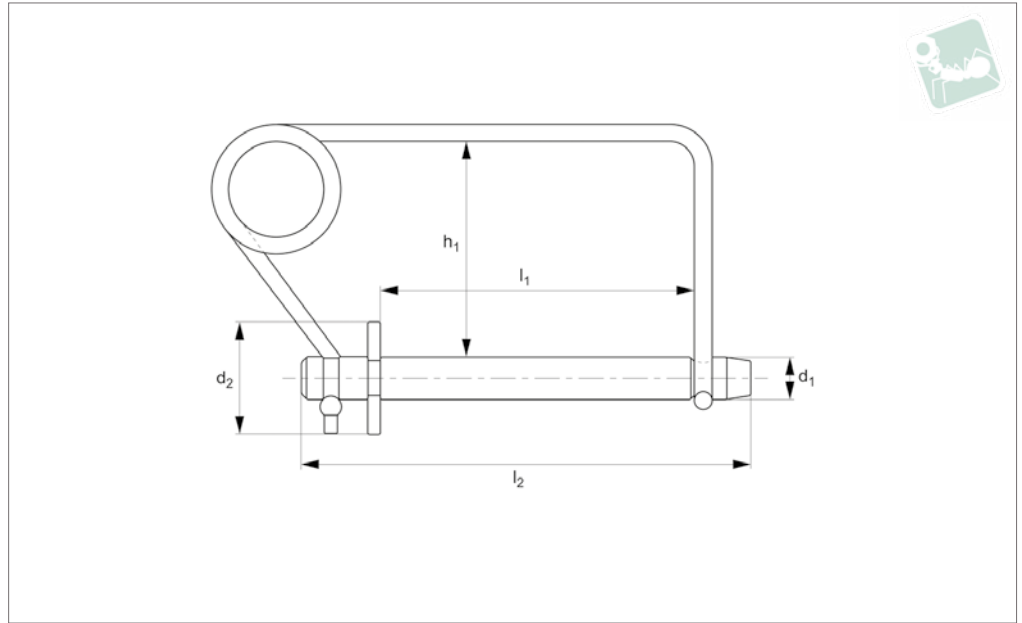

Material

Pin: Carbon steel, C1008-C1010, zinc plated.

Single wire loop: hard drawn spring wire.

Technical Notes

Pin and cotter in one, preventing loss of

parts. Spring wire loop snaps into groove on pin end to provide secure location. Circlip/washer installed on pin creates shoulder, l1 is effective grip length of pin.

Tips

Use lanyard or retaining cable to

permanently attach wire lock pin to assembly, see part nos. L to LA1224.

Order No.	d ₁	l ₁	d ₂	h ₁	l ₂
PP1710.050-350-C	12,7 (1/2")	88,9 (3 1/2")	31.75	63.50	130.30
PP1710.062-400-C	16 (5/8")	101,6 (4")	38.10	85.85	146.05
PP1710.075-400-C	19,05 (3/4")	101,6 (4")	38.10	84.07	146.05
PP1710.075-600-C	19,05 (3/4")	152,4 (6")	38.10	84.07	196.85
PP1710.088-550-C	22,35 (7/8")	139,7 (5 1/2")	44.45	84.07	185.67
PP1710.100-550-C	25,4 (1")	139,7 (5 1/2")	44.45	82.55	185.67



Bent Arm Pins

steel

Pull Pins

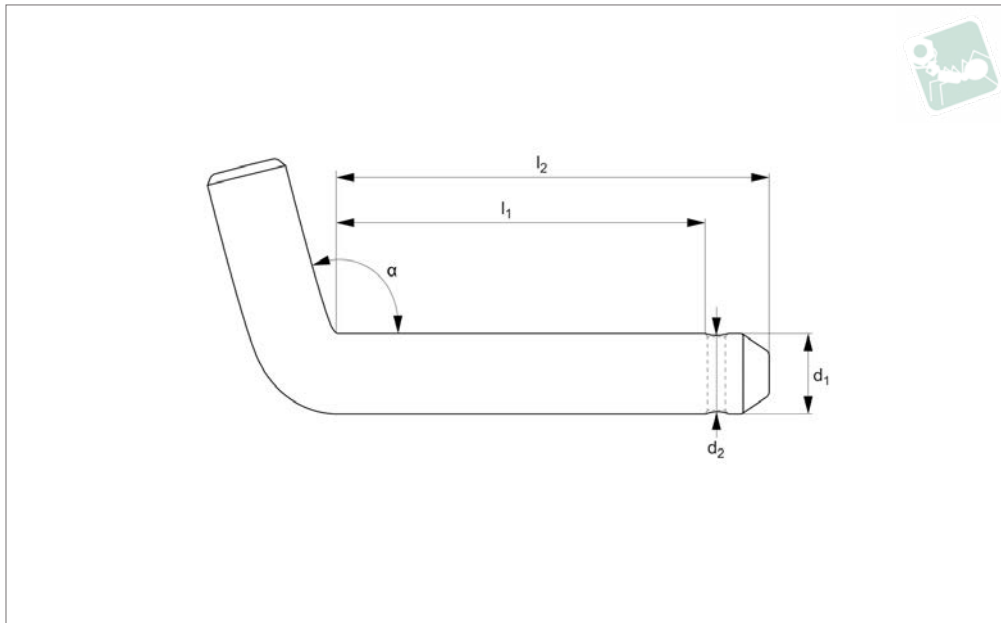

PP1720

PULL PINS

Material

Pin: Carbon steel, C1008-C1010, zinc plated.

Technical Notes

Bent pins provide an economic solution for

applications with repetitive connections.

The 105 degree bend in the pin offers handle and pin in one piece. Once the bent pin is engaged, a suitable cotter pin is used to secure application.

Tips

Also known as Bent Arm Pins, Bent Pins and Hitch Pins.

Order No.	d ₁	l ₁	d ₂	l ₂	α
PP1720.050-250-C	12,7 (1/2")	63,5 (2 1/2")	4.06	79.50	105°
PP1720.050-300-C	12,7 (1/2")	76,2 (3")	4.06	92.20	105°
PP1720.050-400-C	12,7 (1/2")	101,6 (4")	4.06	117.60	105°
PP1720.050-450-C	12,7 (1/2")	114,3 (4 1/2")	4.06	130.30	105°
PP1720.050-500-C	12,7 (1/2")	127 (5")	4.06	136.65	105°
PP1720.062-300-C	16 (5/8")	76,2 (3")	4.85	92.20	105°
PP1720.062-400-C	16 (5/8")	101,6 (4")	4.85	117.60	105°
PP1720.075-350-C	19,05 (3/4")	88,9 (3 1/2")	4.85	104.90	105°
PP1720.075-450-C	19,05 (3/4")	114,3 (4 1/2")	4.85	130.30	105°



PP1722

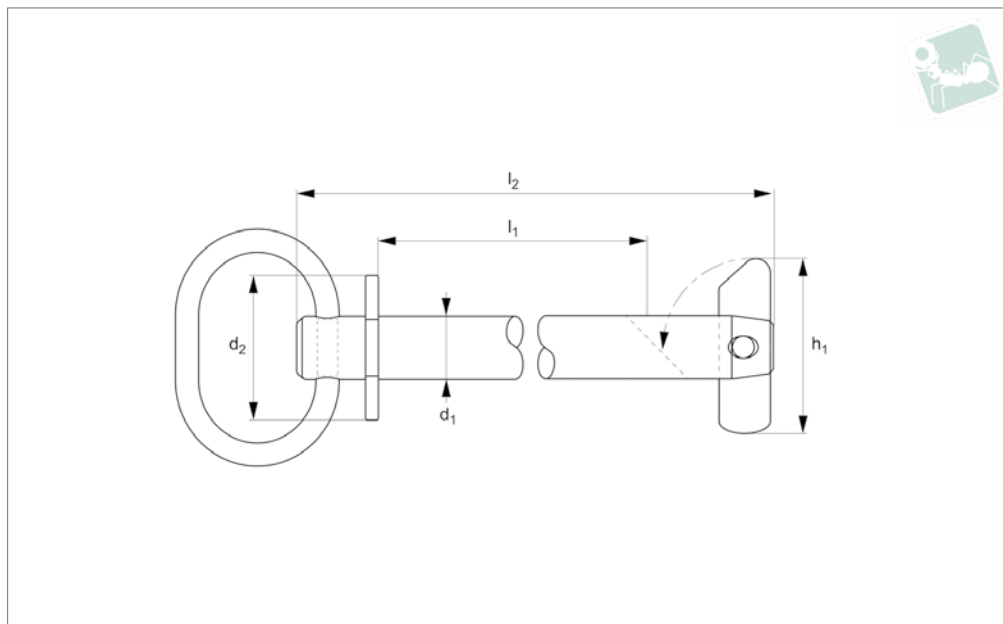

Material

Pin: Carbon steel, C1008-C1010, zinc plated.

Technical Notes

Free rotating toggle at the end of the pin eliminates need for additional fastener

(e.g. hitch pin clip, lynch pin, etc.) to secure. To install the pin, rotate toggle until parallel with the pin and insert in material. After inserting, rotate the toggle 90 degrees to insure the pin will not fall out.

Tips

Use lanyard or retaining cable to permanently attach wire lock pin to assembly, see part nos. L to LA1224.

Order No.	d ₁	l ₁	d ₂	h ₁	l ₂
PP1722.037-275-C	9,65 (3/8")	69,85 (2 3/4")	25.40	25.40	105.66
PP1722.037-400-C	9,65 (3/8")	101,60 (4")	25.40	25.40	137.41
PP1722.150-350-C	38,10 (1 1/2")	88,90 (3 1/2")	31.75	38.10	146.05
PP1722.050-550-C	12,7 (1/2")	139,70 (5 1/2")	31.75	38.10	188.21
PP1722.062-350-C	16,00 (5/8")	88,90 (3 1/2")	38.10	38.10	146.05
PP1722.062-550-C	16,00 (5/8")	139,70 (5 1/2")	38.10	38.10	196.60
PP1722.075-350-C	9,65 (3/4")	88,90 (3 1/2")	38.10	38.10	146.05
PP1722.075-600-C	19,05 (3/4")	152,40 (6")	38.10	38.10	209.55
PP1722.081-625-C	20,57 (13/16")	158,75 (6 1/4")	44.45	38.10	209.55
PP1722.088-350-C	22,35 (7/8")	88,90 (3 1/2")	44.45	38.10	146.05
PP1722.088-600-C	22,35 (7/8")	152,40 (6")	44.45	38.10	209.55
PP1722.100-350-C	25,40 (1")	88,90 (3 1/2")	44.45	38.10	146.05
PP1722.100-600-C	25,40 (1")	152,40 (6")	44.45	38.10	209.55



Hitch Pin - Pin Lock

steel

Pull Pins

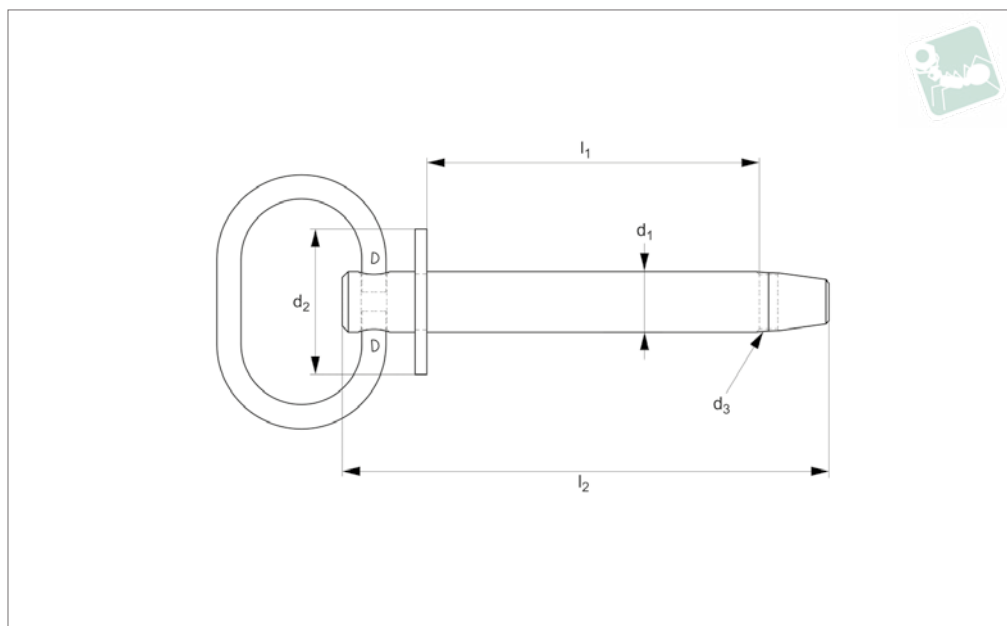

PP1724

PULL PINS

Material

Pin: Carbon steel, C1008-C1010, zinc plated.

Technical Notes

Free rotating toggle at the end of the pin eliminates need for additional fastener

(e.g. hitch pin clip, lynch pin, etc.) to secure. To install the pin, rotate toggle until parallel with the pin and insert in material. After inserting, rotate the toggle 90 degrees to insure the pin will not fall out.

Tips

Use lanyard or retaining cable to permanently attach wire lock pin to assembly, see part nos. L to LA1224.

Order No.	d ₁	l ₁	d ₂	d ₃	l ₂
PP1724.037-300-C	9,65 (3/8")	76,2(3")	25.40	2.77	106.43
PP1724.050-350-C	12,7 (1/2")	88,9(3 1/2")	31.75	3.96	127.00
PP1724.062-450-C	16,0 (5/8")	114,3(4 1/2")	38.10	4.85	155.70
PP1724.075-450-C	19,05 (3/4")	114,3(4 1/2")	38.10	4.85	155.70
PP1724.088-450-C	22,35 (7/8")	114,3(4 1/2")	44.45	4.85	168.40
PP1724.100-450-C	25,4 (1")	114,3(4 1/2")	44.45	4.85	168.40
PP1724.062-600-C	16,0 (5/8")	152,4(6")	44.45	4.85	193.80
PP1724.075-600-C	19,05 (3/4")	152,4(6")	44.45	4.85	193.80
PP1724.088-600-C	22,35 (7/8")	152,4(6")	44.45	4.85	206.50
PP1724.100-600-C	25,4 (1")	152,4(6")	44.45	4.85	206.50
PP1724.113-700-C	28,7 (1 1/8")	177,8(7")	50.80	4.85	231.90
PP1724.125-700-C	31,75 (1 1/4")	177,8(7")	50.80	4.85	231.90



PP1726

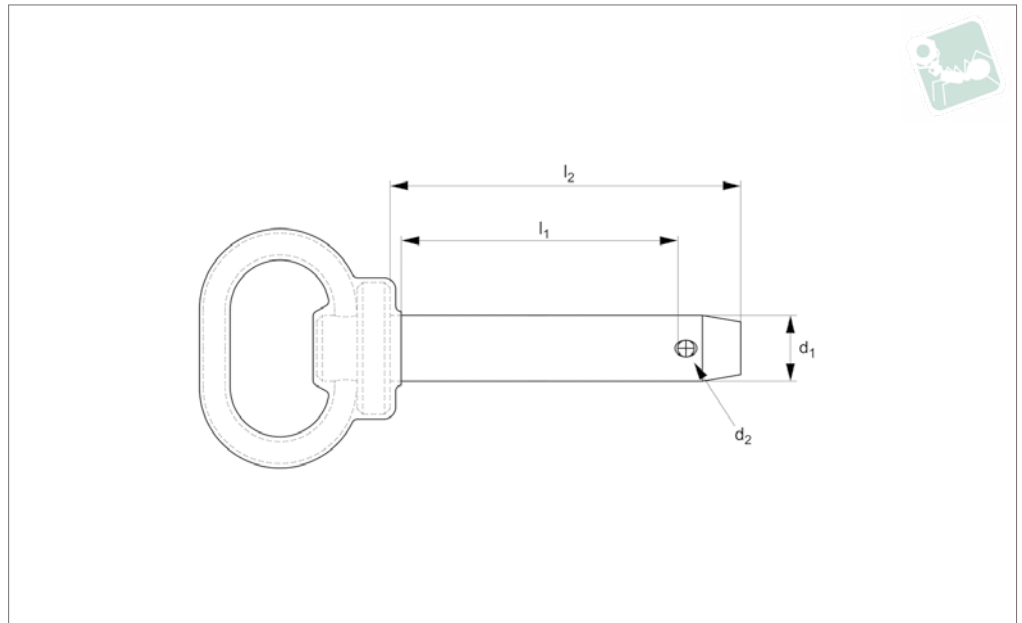

Material

Pin: Carbon steel, C1008-C1010, zinc plated. With plastic coated handle.

Technical Notes

Free rotating toggle at the end of the pin eliminates need for additional fastener (e.g. hitch pin clip, lynch pin, etc.) to secure. To install the pin, rotate toggle

until parallel with the pin and insert in material. After inserting, rotate the toggle 90 degrees to insure the pin will not fall out.

Large handle hitch pin with heavy duty washer to form pin's shoulder. A drilled

hole toward the end of the pin for inserting a keeper fastener; pin clip, lynch pin etc. to sure hitch pin.

Tips

Use lanyard or retaining cable to permanently attach wire lock pin to assembly, see part nos. L to LA1224.

Order No.	d ₁	l ₁	d ₂	l ₂
PP1726.050-400-C	12,7 (1/2")	101,6 (4")	4,06	122,94
PP1726.062-450-C	16 (5/8")	114,3 (4 1/2")	4,85	135,64
PP1726.062-600-C	16 (5/8")	152,4 (6")	2,31	122,94
PP1726.075-450-C	19,05 (3/4")	114,3 (4 1/2")	2,31	136,65
PP1726.075-650-C	19,05 (3/4")	165,1 (6 1/2")	2,31	187,45
PP1726.088-450-C	22,35 (7/8")	114,3 (4 1/2")	2,31	149,35
PP1726.088-650-C	22,35 (7/8")	165,1 (6 1/2")	2,31	200,15
PP1726.100-450-C	25,4 (1")	114,3 (4 1/2")	2,31	149,35
PP1726.100-650-C	25,4 (1")	165,1 (6 1/2")	2,31	200,15
PP1726.113-700-C	28,7 (1 1/8")	177,8 (7")	2,31	212,85
PP1726.125-700-C	31,75 (1 1/4")	177,8 (7")	2,31	212,85

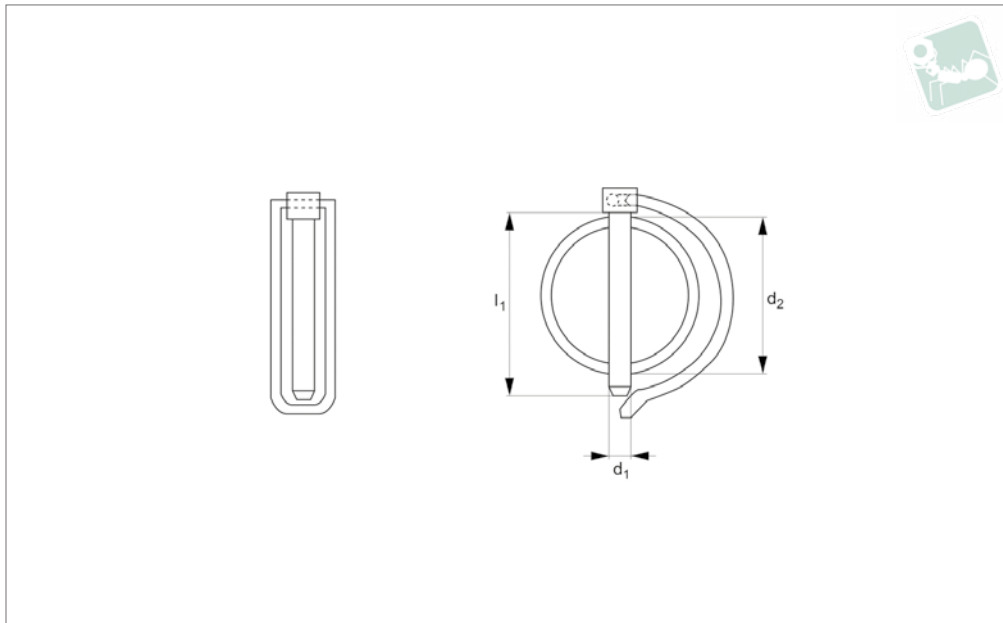

PP1732

PULL PINS

Material

Mild steel, generally silver zinc-plated.
Zinc plating colour will be at manufac-

turers discretion.

Technical Notes

With spring steel „keep“.



PP1730

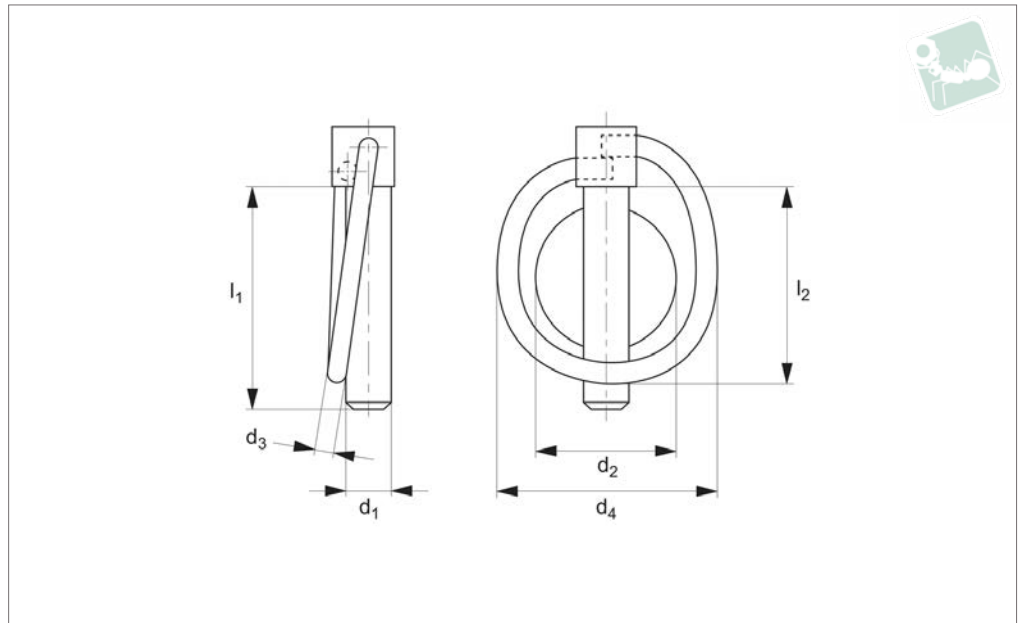

Material

Mild steel, generally yellow zinc plated.

For pin $d_1 = 4,5$ & 6 there is no flat on the pin.

Technical Notes

To DIN 11023. With spring steel „keep“.

Order No.	d_1	l_1	d_2 max.	d_3	d_4	l_2
PP1730.045	4.5	42	25	3.5	41	37
PP1730.060	6.0	42	32	3.5	41	37

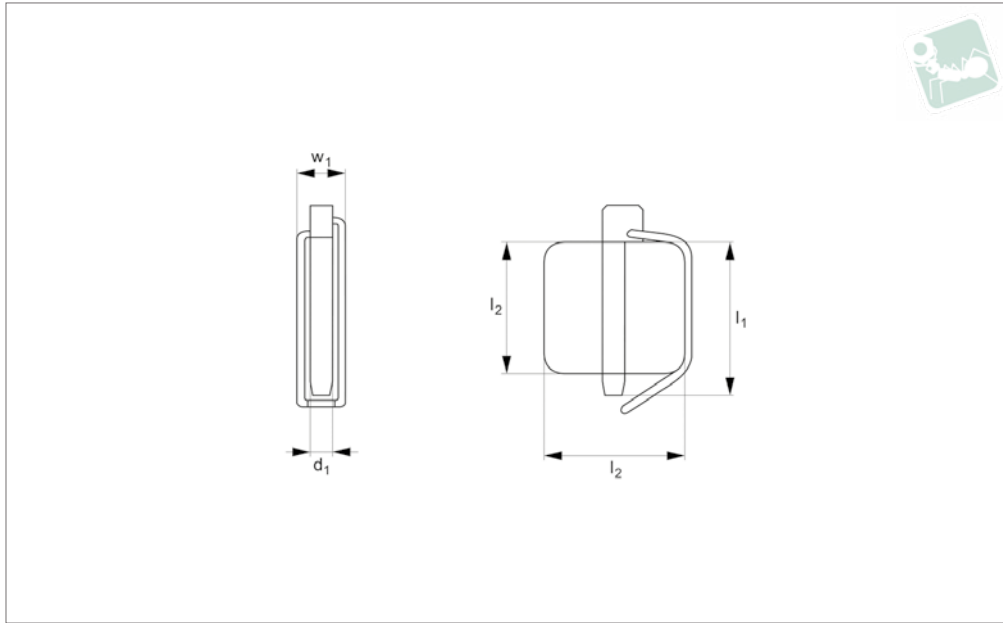

PP1734

PULL PINS

Material

Spring steel (EN10270-1-SM), yellow galvanised.