

SL1018

SPRING LOADED PINS

Material

Steel Type-

Body and Pin: steel 12L14, zinc plated clear chromate finish.

Pull ring: 300 series stainless steel.

Stainless Steel Type-

Body and pin: 300 series stainless steel.

Pull ring: 300 series stainless steel.

Technical Notes

Designed for space limited applications.

Spring loaded pin can be „locked“ to enable pin to be held in retracted/ non-projecting position. Pull back ring handle turn 90° to engage ‚locking‘.

A nylon locking element on thread reduces chance of loosening of thread due to vibra-

tion etc.

Chamfered pin for easy alignment.

Tips

For suitable locknut, see part no. SL1816.

Order No.	Material	d_1 +0.001 -0.001	d_2 UNC tol. 2A	d_3	l_1	l_2	l_3	Spring load f_1 lb	Spring load f_2 lb	Weight g
SL1018.I25-015-C	Steel	0.155	1/4-20	0.62	1.14	0.8	0.250	1.00	2.50	9.0
SL1018.I37-023-C	Steel	0.233	3/8-16	0.98	1.68	1.2	0.375	2.00	4.00	18.0
SL1018.I50-031-C	Steel	0.312	1/2-13	1.26	2.00	1.4	0.500	2.50	5.00	40.5
SL1018.I25-015-S	Stainless	0.155	1/4-20	0.62	1.14	0.8	0.250	1.00	2.50	9.0
SL1018.I37-023-S	Stainless	0.233	3/8-16	0.98	1.68	1.2	0.375	2.00	4.00	18.0
SL1018.I50-031-S	Stainless	0.312	1/2-13	1.26	2.00	1.4	0.500	2.50	5.00	40.5

Spring Loaded Pins

Spring Loaded Pin - Inch - Ring non-locking



SPRING LOADED PINS



SL1016

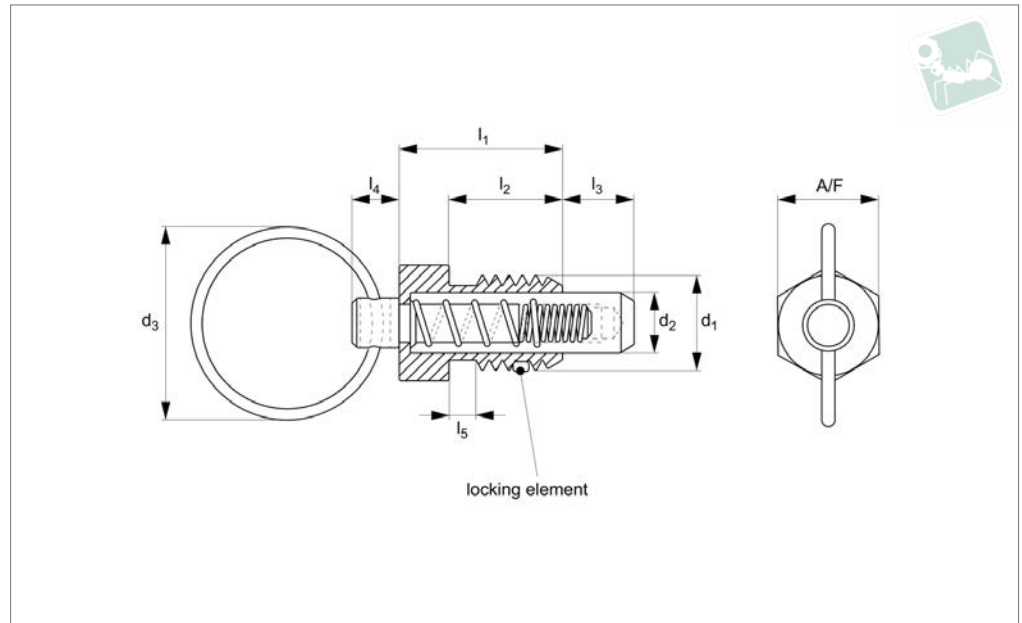

Material

Steel Type-

Body and Pin: steel 12L14, zinc plated clear chromate finish.

Pull ring: 300 series stainless steel.

Stainless Steel Type-

Body and pin: 300 series stainless steel.

Pull ring: 300 series stainless steel.

Technical Notes

Designed for space limited applications.

Spring loaded pin is non-locking, pin simply springs back when grip released.

A nylon locking element on thread reduces

chance of loosening of thread due to vibration etc.

Chamfered pin for easy alignment.

Tips

For suitable locknut, see part no. SL1816.

Order No.	Material	d ₁	d ₂ UNC tol. 2A	d ₃	l ₁	l ₂	l ₃	l ₄	l ₅	A/F	Spring load f ₁ lb	Spring load f ₂ lb
SL1016.I25-016-C	Steel	1/4-20	0.16	0.62	0.44	0.31	0.19	0.18	-	0.25	0.50	2.0
SL1016.I37-025-C	Steel	3/8-16	0.25	0.75	0.63	0.44	0.28	0.19	0.13	0.38	0.75	3.0
SL1016.I50-031-C	Steel	1/2-13	0.31	1.00	0.81	0.56	0.38	0.25	0.13	0.50	1.00	4.0
SL1016.I62-038-C	Steel	5/8-11	0.38	1.00	1.00	0.69	0.44	0.31	0.13	0.62	1.25	5.0
SL1016.I25-016-S	Stainless	1/4-20	0.16	0.62	0.44	0.31	0.19	0.18	-	0.25	0.50	2.0
SL1016.I37-025-S	Stainless	3/8-16	0.25	0.75	0.63	0.44	0.28	0.19	0.13	0.38	0.75	3.0
SL1016.I50-031-S	Stainless	1/2-13	0.31	1.00	0.81	0.56	0.38	0.25	0.13	0.50	1.00	4.0
SL1016.I62-038-S	Stainless	5/8-11	0.38	1.00	1.00	0.69	0.44	0.31	0.13	0.62	1.25	5.0

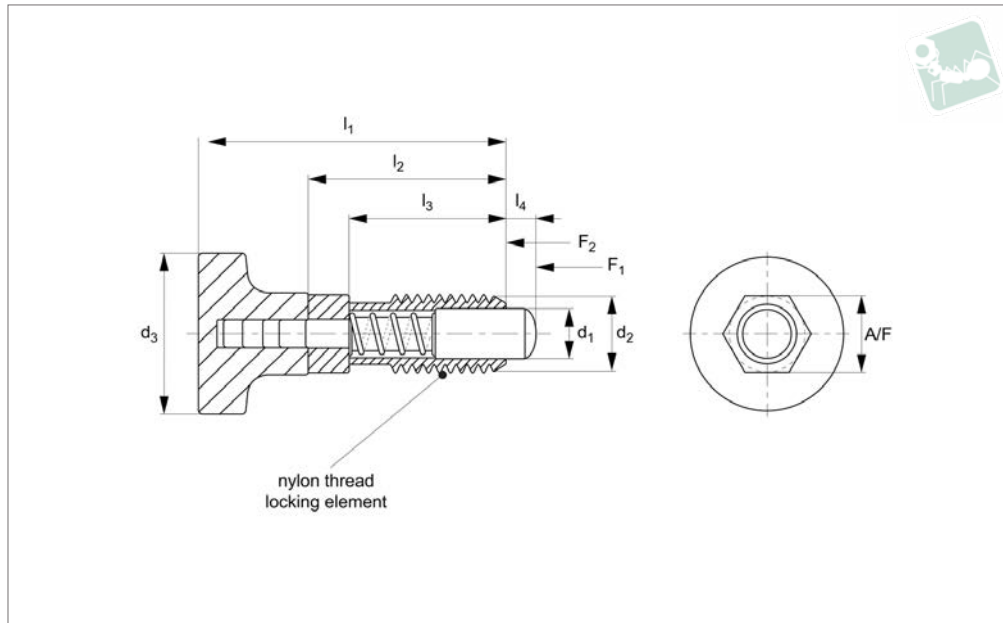

SL1611

SPRING LOADED PINS

Material

Steel Type-

Body: Steel 12L14.

Pin: Steel case, hardened.

Grip: Thermoplastic, black.

Stainless Type-

Body: 300 series stainless steel.

Pin: 300 series stainless steel.

Grip: Thermoplastic, white.

Technical Notes

Spring loaded pin is non-locking, pin simply springs back when grip released.

A nylon locking element on thread reduces

chance of loosening of thread due to vibration etc.

Tips

Stainless steel type ideal for food and medical applications.

For suitable locknut, see part no. SL1810.

Order No.	Material	d ₁	d ₂ tol. 8g	l ₁	l ₂	l ₃	l ₄	d ₃	A/F	Spring load F ₁ N	Spring load F ₂ N
SL1611.M06-003-C	Steel	3	M 6 x 1,00	25	16	13	3	12	6	0.49	1.51
SL1611.M10-006-C	Steel	6	M10 x 1,50	38	25	20	5	19	10	0.98	8.99
SL1611.M12-008-C	Steel	8	M12 x 1,75	47	31	25	6	25	12	2.49	8.01
SL1611.M06-003-S	Stainless	3	M 6 x 1,00	25	16	13	3	12	6	0.49	1.51
SL1611.M10-006-S	Stainless	6	M10 x 1,50	38	25	20	5	19	10	0.98	8.99
SL1611.M12-008-S	Stainless	8	M12 x 1,75	47	31	25	6	25	12	2.49	8.01

Spring Loaded Pins

Spring Loaded Pin - Inch - Pull Grip non-locking



SPRING LOADED PINS



SL1616

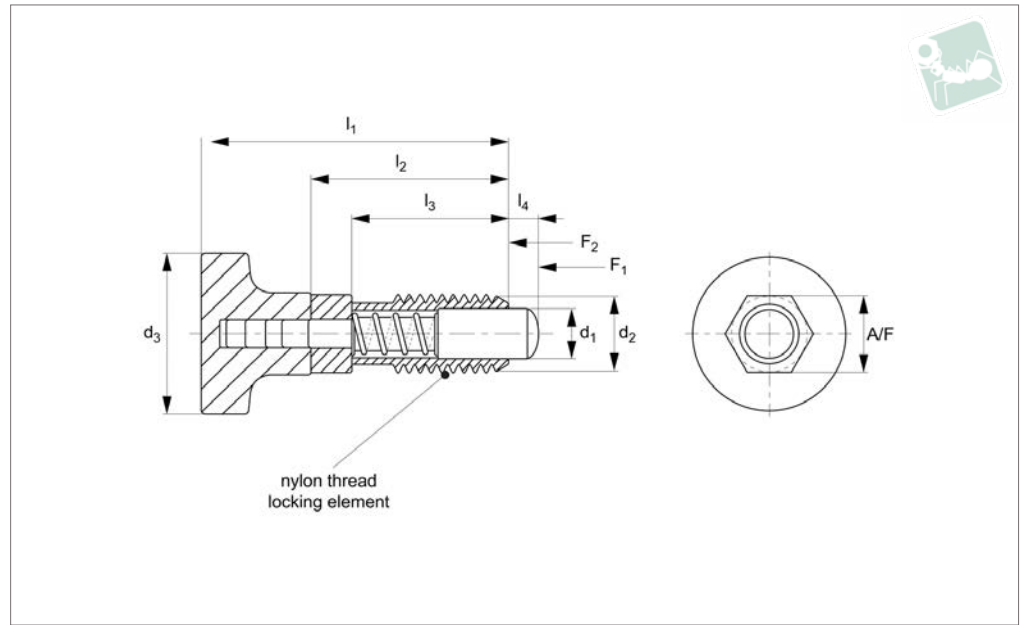

Material

Steel Type-

Body: Steel 12L14.

Pin: Steel case hardened steel.

Grip: Thermoplastic, black.

Stainless Type-

Body: 300 series stainless steel.

Pin: 300 series stainless steel.

Grip: Thermoplastic, white.

Technical Notes

Spring loaded pin is non-locking, pin simply springs back when grip released.

A nylon locking element on thread reduces chance of loosening of thread due to vibra-

tion etc.

Tips

Stainless steel type ideal for food and medical applications.

For suitable locknut, see part no. SL1816.

Order No.	Material	d ₁	d ₃ UNC tol. 2A	l ₁	l ₂	l ₃	l ₄	d ₃	A/F	Spring load f ₁ lb	Spring load f ₂ lb
SL1616.I25-016-C	Steel	0.16	1/4-20	0.96	0.63	0.50	0.13	0.50	1/4	0.12	0.36
SL1616.I37-025-C	Steel	0.25	3/8-16	1.40	0.94	0.75	0.18	0.75	3/8	0.25	2.00
SL1616.I50-031-C	Steel	0.31	1/2-13	1.90	1.25	1.00	0.25	1.00	1/2	0.50	1.75
SL1616.I25-016-S	Stainless	0.16	1/4-20	0.96	0.63	0.50	0.13	0.50	1/4	0.12	0.36
SL1616.I37-025-S	Stainless	0.25	3/8-16	1.40	0.94	0.75	0.18	0.75	3/8	0.25	2.00
SL1616.I50-031-S	Stainless	0.31	1/2-13	1.90	1.25	1.00	0.25	1.00	1/2	0.50	1.75

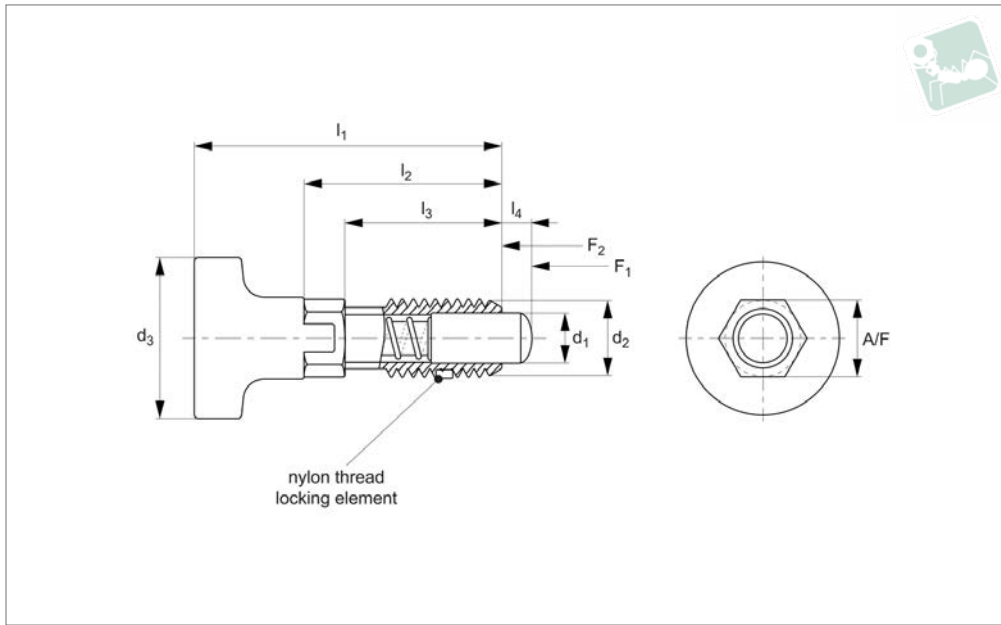

SL1613

SPRING LOADED PINS

Material

Steel Type-

Body: Steel 12L14.
Pin: Case hardened steel.
Grip: Thermoplastic, black.

Stainless Steel Type-

Body: 300 series stainless steel.

Pin: 300 series stainless steel.
Grip: Thermoplastic, white.

Technical Notes

Spring loaded pin can be ,locked' to enable pin to be held in retracted/ non-projecting position. Pull back grip handle turn 90° to engage ,locking'.

A nylon locking element on thread reduces chance of loosening of thread due to vibration etc.

Tips

Stainless type ideal for food and medical applications.
For suitable locknut, see part no. SL1810.

Order No.	Material	d ₁	d ₂ tol. 8g	l ₁	l ₂	l ₃	l ₄	d ₃	A/F	Spring load F ₁ N	Spring load F ₂ N
SL1613.M06-003-C	Steel	3	M 6 x 1,00	25	19	13	3	12	6	0.49	1.51
SL1613.M10-006-C	Steel	6	M10 x 1,50	38	30	20	5	19	10	0.98	8.99
SL1613.M12-008-C	Steel	8	M12 x 1,75	47	37	25	6	25	12	2.49	8.01
SL1613.M06-003-S	Stainless	3	M 6 x 1,00	25	19	13	3	12	6	0.49	1.51
SL1613.M10-006-S	Stainless	6	M10 x 1,50	38	30	20	5	19	10	0.98	8.99
SL1613.M12-008-S	Stainless	8	M12 x 1,75	47	37	25	6	25	12	2.49	8.01



SL1618

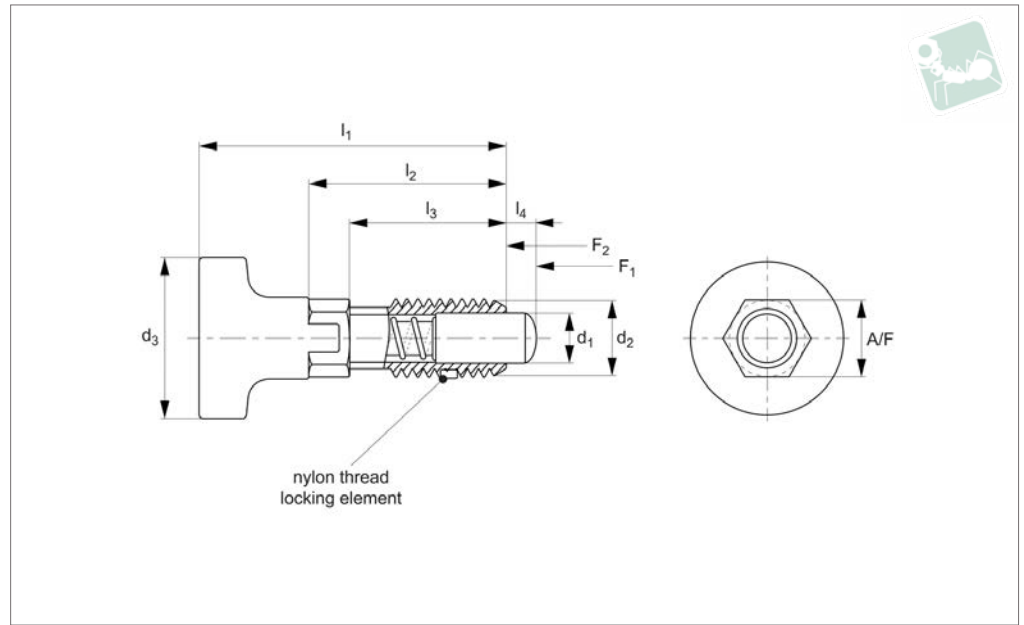

Material

Steel Type-

Body: Steel 12L14.

Pin: Case hardened steel.

Grip: Thermoplastic, black.

Stainless Steel Type-

Body: 300 series stainless steel.

Pin: 300 stainless steel.

Grip: Thermoplastic, white.

Technical Notes

Spring loaded pin can be ,locked' to enable pin to be held in retracted/ non-projecting position. Pull back grip handle turn 90° to engage ,locking'.

A nylon locking element on thread reduces chance of loosening of thread due to vibration etc.

Tips

Stainless type ideal for food and medical applications.

For suitable locknut, see part no. SL1816.

Order No.	Material	d ₁	d ₂ UNC	l ₁	l ₂	l ₃	l ₄	d ₃	A/F	Spring force f ₁ lb	Spring force f ₂ lb
SL1618.I25-016-C	Steel	0.16	1/4-20	0.97	0.75	0.50	0.13	0.50	1/4	0.12	0.36
SL1618.I37-025-C	Steel	0.25	3/8-16	1.40	1.13	0.75	0.18	0.75	3/8	0.25	2.00
SL1618.I50-031-C	Steel	0.31	1/2-13	1.90	1.50	1.00	0.25	1.00	1/2	0.50	1.75
SL1618.I25-016-S	Stainless	0.16	1/4-20	0.97	0.75	0.50	0.13	0.50	1/4	0.12	0.36
SL1618.I37-025-S	Stainless	0.25	3/8-16	1.40	1.13	0.75	0.18	0.75	3/8	0.25	2.00
SL1618.I50-031-S	Stainless	0.31	1/2-13	1.90	1.50	1.00	0.25	1.00	1/2	0.50	1.75



Spring Loaded Pin - Metric - Pull Grip

non-locking - metal grip

Spring Loaded Pins

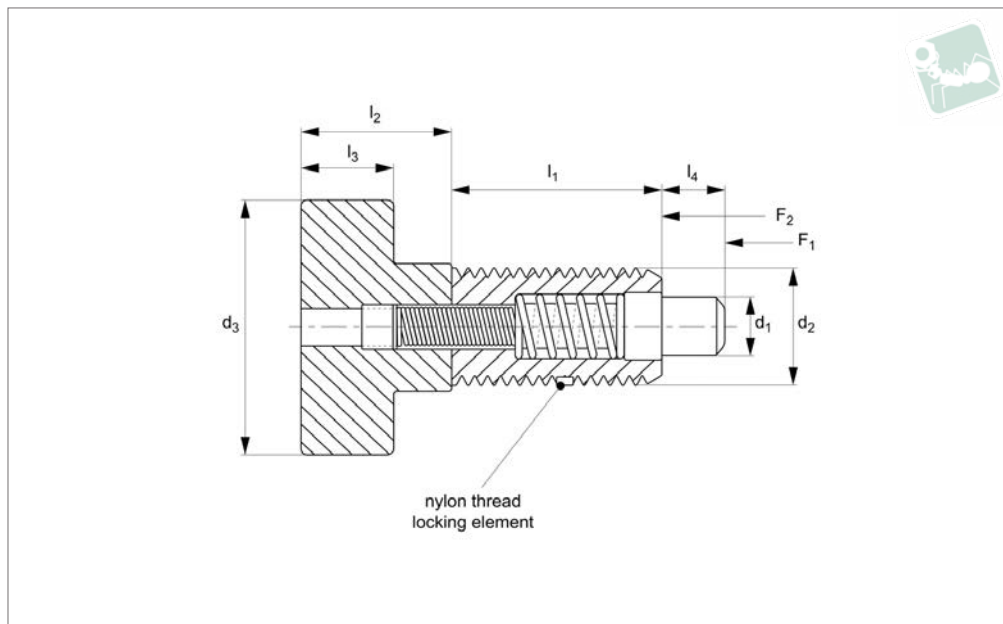

SL1410

SPRING LOADED PINS

Material

Steel Type-

Body, Pin and Grip: steel 12L14, zinc plate yellow chromate finish.

Stainless Steel Type-

Body, Pin and Grip: 303 series stainless

steel.

Technical Notes

Spring loaded pin is non-locking, pin simply springs back when grip released. A nylon locking element on thread reduces chance of loosening of thread due to vibra-

tion etc.

Tips

Metal grip for more robust handling. For suitable locknut, see part no. SL1810.

Order No.	Material	d_1 +0.000 -0.001	d_2 tol. 6g	d_3	l_1	l_2	l_3	l_4	Spring force f_1 N	Spring force f_2 N
SL1410.M05-250-C	Steel	2.5	M 5 x 0,80	9	10	6	4	2	2.22	13.35
SL1410.M06-030-C	Steel	3.0	M 6 x 1,00	13	13	8	5	3	4.45	17.80
SL1410.M10-050-C	Steel	5.0	M10 x 1,50	19	19	13	8	6	4.45	35.60
SL1410.M12-060-C	Steel	6.0	M12 x 1,75	25	23	16	10	6	4.45	44.50
SL1410.M05-250-S	Stainless	2.5	M 5 x 0,80	9	10	6	4	2	2.22	13.35
SL1410.M06-030-S	Stainless	3.0	M 6 x 1,00	13	13	8	5	3	4.45	17.80
SL1410.M10-050-S	Stainless	5.0	M10 x 1,50	19	19	13	8	6	4.45	35.60
SL1410.M12-060-S	Stainless	6.0	M12 x 1,75	25	23	16	10	6	4.45	44.50

Spring Loaded Pins

Spring Loaded Pin - Inch - Pull Grip

non-locking - metal grip



SPRING LOADED PINS



SL1416

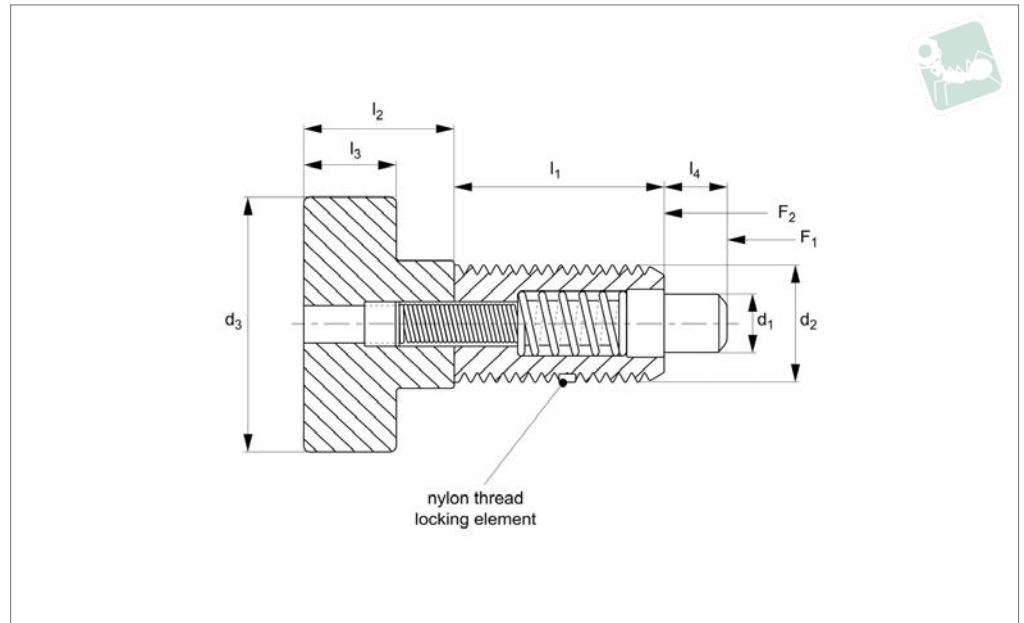

Material

Steel Type-

Body, Pin and Grip: steel 12L14, zinc plate yellow chromate finish.

Stainless Steel Type-

Body: 300 series stainless steel.

Plunger: 300 series stainless steel.

Technical Notes

Spring loaded pin is non-locking, pin simply springs back when grip released. A nylon locking element on thread reduces chance of loosening of thread due to vibra-

tion etc.

Tips

Metal grip for more robust handling. For suitable locknut, see part no. SL1816.

Order No.	Material	d_1 +0.000 -0.0254	d_2 UNC	d_3	l_1	l_2	l_3	l_4	Spring force f_1 lb	Spring force f_2 lb	Weight g
SL1416.I19-010-C	Steel	0.104	10-32	0.38	0.400	0.250	0.190	0.094	0.5	3.00	9
SL1416.I25-012-C	Steel	0.123	1/4-20	0.50	0.500	0.313	0.190	0.125	1.0	4.00	9
SL1416.I31-015-C	Steel	0.154	5/16-18	0.63	0.625	0.375	0.250	0.188	1.0	6.00	18
SL1416.I37-018-C	Steel	0.185	3/8-16	0.75	0.750	0.500	0.310	0.218	1.0	8.00	27
SL1416.I50-024-C	Steel	0.248	1/2-13	1.00	0.875	0.625	0.380	0.250	1.0	10.0	36
SL1416.I19-010-S	Stainless	0.104	10-32	0.38	0.400	0.250	0.190	0.094	0.5	3.00	9
SL1416.I25-012-S	Stainless	0.123	1/4-20	0.50	0.500	0.313	0.190	0.125	1.0	4.00	9
SL1416.I31-015-S	Stainless	0.154	5/16-18	0.63	0.625	0.375	0.250	0.188	1.0	6.00	18
SL1416.I37-018-S	Stainless	0.185	3/8-16	0.75	0.750	0.500	0.310	0.218	1.0	8.00	27
SL1416.I50-024-S	Stainless	0.248	1/2-13	1.00	0.875	0.625	0.380	0.250	1.0	10.0	36



Spring Loaded Pin - Inch - Pull Grip

locking - metal grip

Spring Loaded Pins

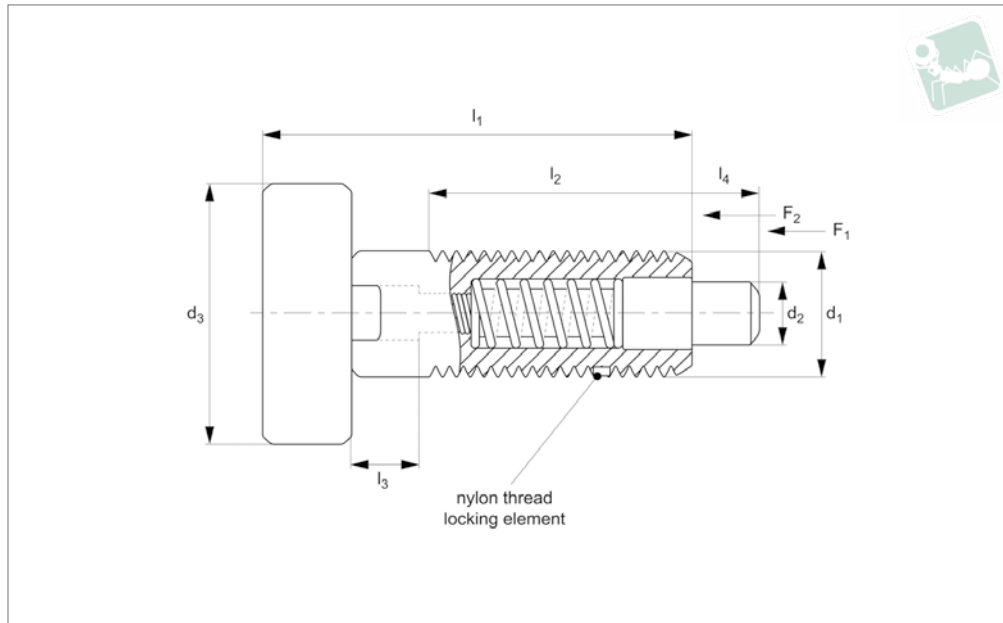

SL1418

SPRING LOADED PINS

Material

Steel Type-

Body, Pin and Grip: steel 12L14, zinc plate yellow chromate finish.

Stainless Steel Type-

Body, Pin and Grip: 300 series stainless steel.

Technical Notes

Spring loaded pin can be 'locked' to enable pin to be held in retracted/ non-projecting position. Pull back grip handle turn 90° to engage 'locking'.

A nylon locking element on thread reduces chance of loosening of thread due to vibra-

tion etc.

Tips

Metal grip for more robust handling. For suitable locknut, see part no. SL1816.

Order No.	Material	d ₁ +0.001 -0.001	d ₂ UNC	d ₃	l ₁	l ₂	l ₃	Spring force f ₁ lb	Spring force f ₂ lb	Weight g
SL1418.I25-012-C	Steel	0.12	1/4-20	0.50	0.80	0.400	0.125	0.50	2.0	9
SL1418.I37-018-C	Steel	0.18	3/8-16	0.75	1.26	0.750	0.220	0.50	3.0	27
SL1418.I50-024-C	Steel	0.24	1/2-13	1.00	1.38	0.650	0.250	0.50	4.0	36
SL1418.I25-012-S	Stainless	0.12	1/4-20	0.50	0.80	0.400	0.125	0.50	2.0	9
SL1418.I37-018-S	Stainless	0.18	3/8-16	0.75	1.26	0.750	0.220	0.50	3.0	27
SL1418.I50-024-S	Stainless	0.24	1/2-13	1.00	1.38	0.650	0.250	0.50	4.0	36

Spring Loaded Pins

Spring Loaded Pin - Inch - Pull Grip

locking - metal grip



SPRING LOADED PINS



SL1419

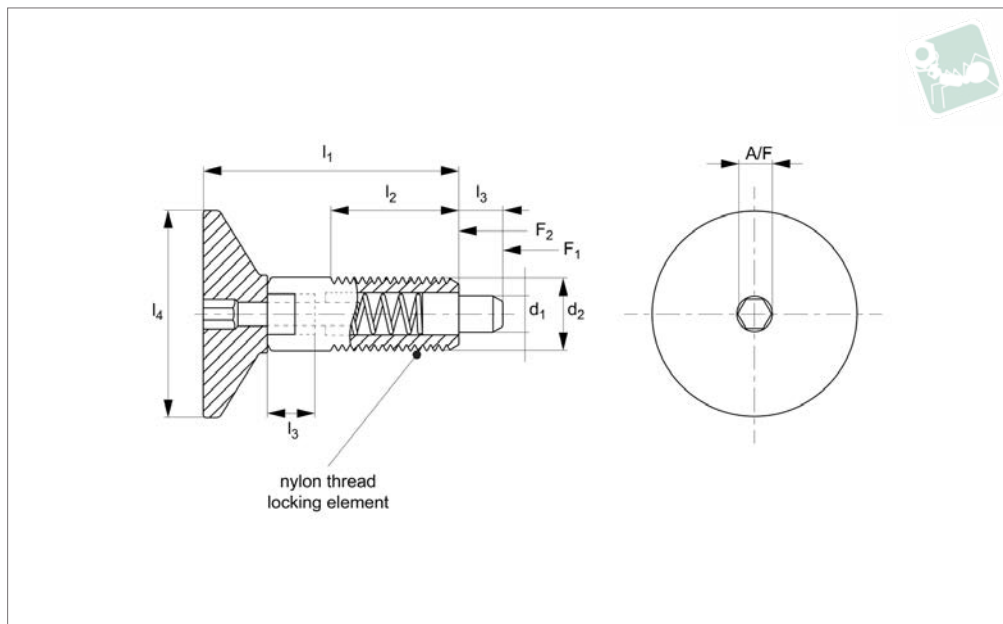

Material

Body, Pin and Grip: Steel 12L14, zinc gold chromate finish.

Technical Notes

Spring loaded pin can be 'locked' to enable

pin to be held in retracted/ non-projecting position. Pull back grip handle turn 90° to engage 'locking'.

A nylon locking element on thread reduces chance of loosening of thread due to vibra-

tion etc.

Tips

Metal grip has recessed hex to improve ease of installation.

For suitable locknut, see part no. SL1816.

Order No.	Material	d ₁	d ₂ UNC	l ₁	l ₂	l ₃	l ₄	A/F	Spring force f ₁ lb	Spring force f ₂ lb
SL1419.I25-012-Z	Steel	0.123	1/4-20	0.805	0.40	0.125	0.750	0.125	1	4
SL1419.I31-015-Z	Steel	0.154	5/16-18	1.070	0.53	0.187	0.875	0.125	1	6
SL1419.I37-018-Z	Steel	0.185	3/8-16	1.260	0.75	0.220	1.000	0.218	1	8
SL1419.I50-024-Z	Steel	0.248	1/2-13	1.380	0.65	0.250	1.250	0.250	1	10



Index Plungers - Lever Grip

locking - coarse thread

Spring Loaded Pins

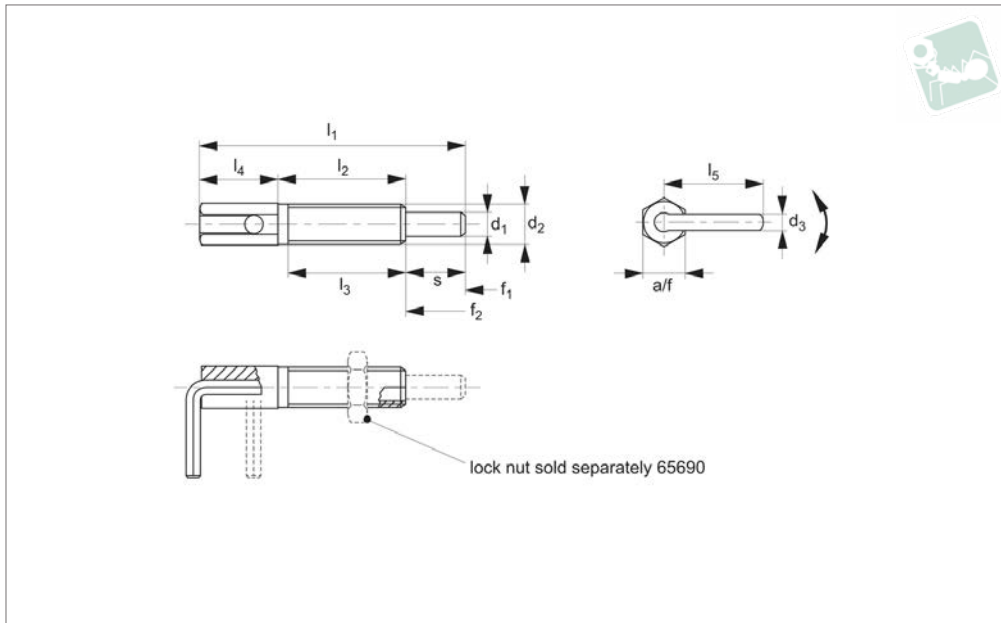

SL1112

SPRING LOADED PINS

Material

Body: free cutting steel, zinc plated.
Pin: steel, galvanised.
Lever: steel, galvanised.

Technical Notes

Pull back and turn lever 180° to retract pin.

To enable pin to be held in retracted position, secure lever in notched catch on plunger body.
For applications where high precision is not required.
Coarse thread.

Temperature resistance up to 250°C

Lock nuts sold separately. See product 65690.

Tips

Spring loads* = statistical average.

Order No.	Type	d ₁	d ₂	d ₃	l ₁	l ₂	l ₃	l ₄	l ₅	s	A/F	Spring load F ₁ N ≈	Spring load F ₂ N ≈	Tightening torque Nm max.	Weight g
SL1112.M06-004-C	Locking	4	M 6x1,00	2,3	41,5	20,0	17,0	12,0	15,5	9,5	6	3,0	10,0	1,6	6
SL1112.M08-005-C	Locking	5	M 8x1,25	3,0	54,0	27,0	24,0	15,0	19,2	12,0	8	3,5	13,5	4,5	14
SL1112.M10-006-C	Locking	6	M10x1,50	3,5	65,0	33,5	30,0	17,5	22,9	14,0	10	4,0	16,0	10,0	26
SL1112.M12-008-C	Locking	8	M12x1,75	4,7	73,0	31,8	28,0	22,2	31,2	19,0	12	4,0	22,0	13,0	55
SL1112.M16-010-C	Locking	10	M16x2,00	4,7	102,5	50,5	44,5	27,0	32,7	25,0	16	4,0	23,0	42,0	103



SL1113

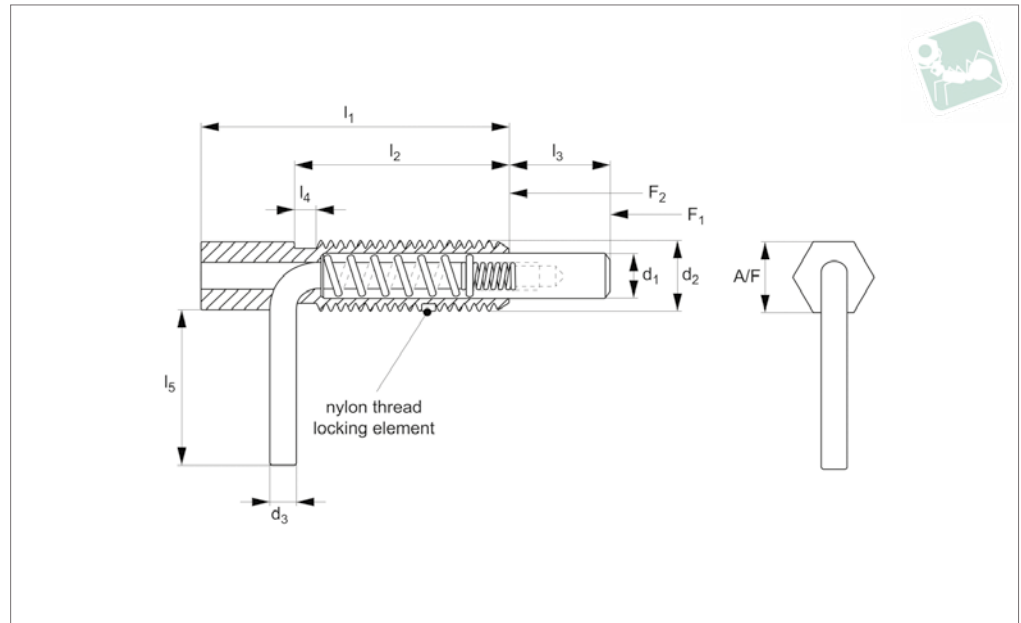

Material

Steel Type-

Body and pin: steel 12L14, zinc plate clear chromate finish.

Stainless Steel Type -

Body and pin: 300 series stainless steel.

Technical Notes

Spring loaded pin can be „locked“ to enable pin to be held in retracted/ non-projecting position. Pull back lever, turn 90° to engage „locking“.

A nylon locking element on thread reduces

chance of loosening of thread due to vibration etc.

Tips

For suitable locknut, see part no. SL1810.

Order No.	Material	d ₁	d ₂ tol. 5g	l ₁	l ₂	l ₃	l ₄	l ₅	d ₃	Spring force f ₁ N	Spring force f ₂ N
SL1113.M06-004-C	Steel	4	M 6 x 1,00	32	20	10	-	12.7	2.3	2.2	11.1
SL1113.M10-006-C	Steel	6	M10 x 1,50	51	33	14	3.3	19.0	3.5	3.3	16.7
SL1113.M12-007-C	Steel	7	M12 x 1,75	54	32	19	3.8	25.4	4.8	4.5	22.2
SL1113.M06-004-S	Stainless Steel	4	M 6 x 1,00	32	20	10	-	12.7	2.3	2.2	11.1
SL1113.M10-006-S	Stainless Steel	6	M10 x 1,50	51	33	14	3.3	19.0	3.5	3.3	16.7
SL1113.M12-007-S	Stainless Steel	7	M12 x 1,75	54	32	19	3.8	25.4	4.8	4.5	22.2
SL1113.M08-005-C	Locking	5	M 8x1,25	3.0	54.0	27.0	24.0	15.0	19.2	3.5	14
SL1113.M16-010-C	Locking	10	M16x2,00	4.7	102.5	50.5	44.5	27.0	32.7	4.0	103



Spring Loaded Pin - Inch - Lever non-locking

Spring Loaded Pins

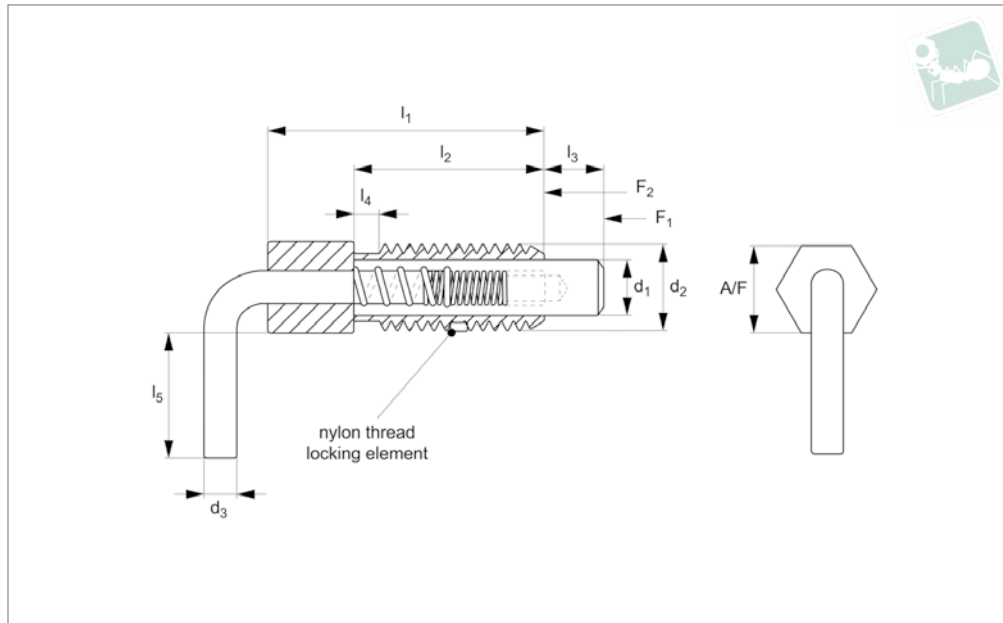

SL1116

SPRING LOADED PINS

Material

Body and pin: steel 12L14.

Technical Notes

Spring loaded pin is non-locking, pin

simply springs back when lever released.

A nylon locking element on thread reduces chance of loosening of thread due to vibration etc.

Tips

For suitable locknut, see part no. SL1816.

Order No.	d ₁	d ₂ UNC	l ₁	l ₂	l ₃	l ₄	l ₅	d ₃	A/F	Spring force f ₁ lb	Spring force f ₂ lb
SL1116.I25-016-C	0.16	1/4-20	1.25	0.80	0.38	-	0.50	0.09	0.25	0.50	2.50
SL1116.I37-025-C	0.25	3/8-16	2.00	1.31	0.56	0.13	0.75	0.14	0.38	0.38	3.75
SL1116.I50-031-C	0.31	1/2-13	2.00	1.25	0.75	0.15	1.00	0.19	0.50	1.00	5.00
SL1116.I62-038-C	0.38	5/8-11	3.05	2.00	1.00	0.18	1.00	0.19	0.62	1.00	5.00



SL1118

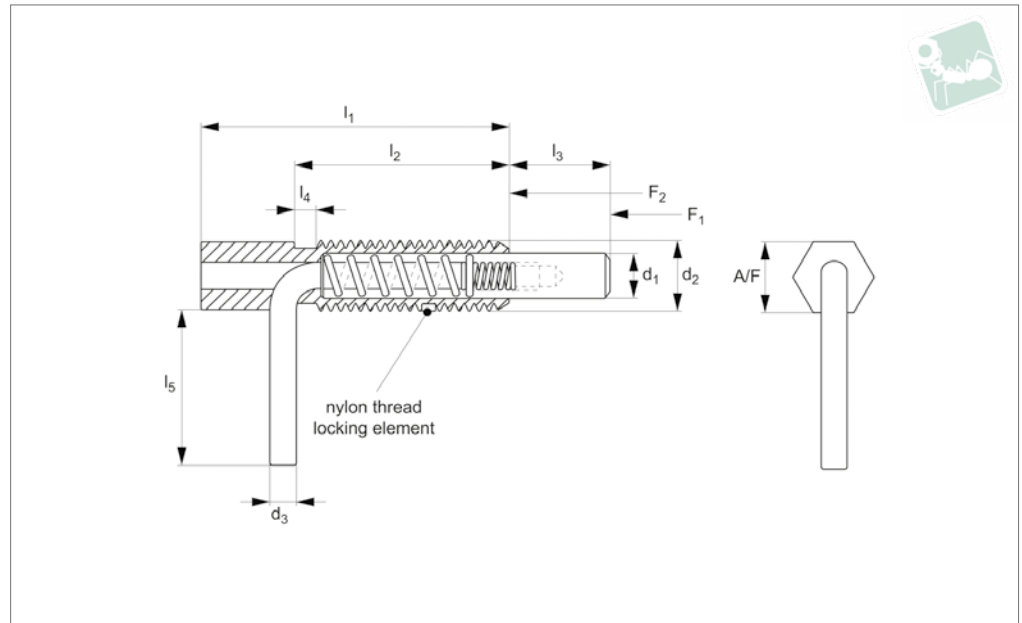

Material

Steel Type-

Body and pin: steel 12L14, zinc plate clear chromate finish.

Stainless Steel Type -

Body and pin: 300 series stainless steel.

Technical Notes

Spring loaded pin can be „locked“ to enable pin to be held in retracted/ non-projecting position. Pull back lever, turn 90° to engage ‚locking‘.

A nylon locking element on thread reduces

chance of loosening of thread due to vibration etc.

Tips

For suitable locknut, see part no. SL1816.

Order No.	Material	d ₁	d ₂ UNC	l ₁	l ₂	l ₃	l ₄	l ₅	d ₃	Spring force f ₁ lb	Spring force f ₂ lb	Weight g
SL1118.I25-016-C	Steel	0.16	1/4-20	1.25	0.80	0.38	-	0.50	0.09	0.50	2.50	9.0
SL1118.I37-023-C	Steel	0.23	3/8-16	2.00	1.31	0.56	0.13	0.75	0.14	0.75	3.75	22.5
SL1118.I50-031-C	Steel	0.31	1/2-13	2.11	1.25	0.75	0.15	0.93	0.19	1.00	5.00	45.0
SL1118.I62-038-C	Steel	0.38	5/8-11	3.05	2.00	1.00	0.18	1.00	0.19	1.00	5.00	67.5
SL1118.I25-016-S	Stainless	0.16	1/4-20	1.25	0.80	0.38	-	0.50	0.09	0.50	2.50	9.0
SL1118.I37-023-S	Stainless	0.23	3/8-16	2.00	1.31	0.56	0.13	0.75	0.14	0.75	3.75	22.5
SL1118.I50-031-S	Stainless	0.31	1/2-13	2.11	1.25	0.75	0.15	0.93	0.19	1.00	5.00	45.0
SL1118.I62-038-S	Stainless	0.38	5/8-11	3.05	2.00	1.00	0.18	1.00	0.19	1.00	5.00	67.5



Spring Loaded Pin - Inch - Lever

locking - blackened

Spring Loaded Pins

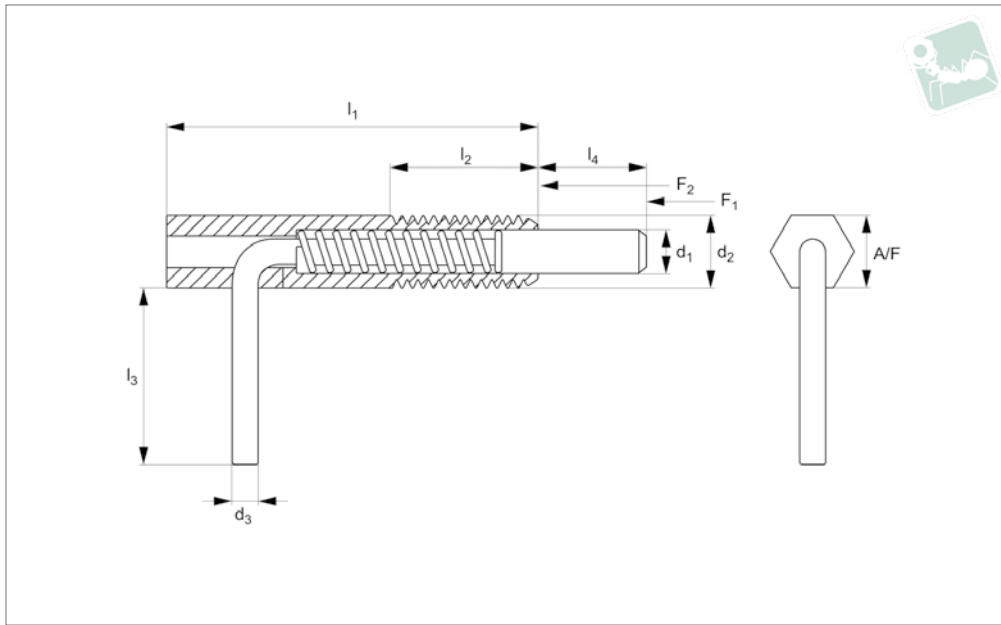

SL1119

SPRING LOADED PINS

Material

Body and pin: steel 12L14, black oxide finish.

enable pin to be held in retracted/ non-projecting position. Pull back lever, turn 90° to engage 'locking'.

Technical Notes

Spring loaded pin can be „locked“ to

Tips

For suitable locknut, see part no. SL1816.

Order No.	d_1 +0.000 -0.001	d_2 UNC	l_1	l_2	l_3	l_4	d_3	A/F	Spring force f_1 lb	Spring force f_2 lb
SL1119.I25-038-C	0.155	1/4-20	1.25	0.50	0.50	0.38	0.101	1/4	0.50	2.50
SL1119.I37-056-C	0.234	3/8-16	2.00	1.00	0.74	0.56	0.134	3/8	0.75	3.75
SL1119.I50-031-C	0.313	1/2-13	2.11	1.11	1.00	0.75	0.188	1/2	1.00	5.00



SL1218

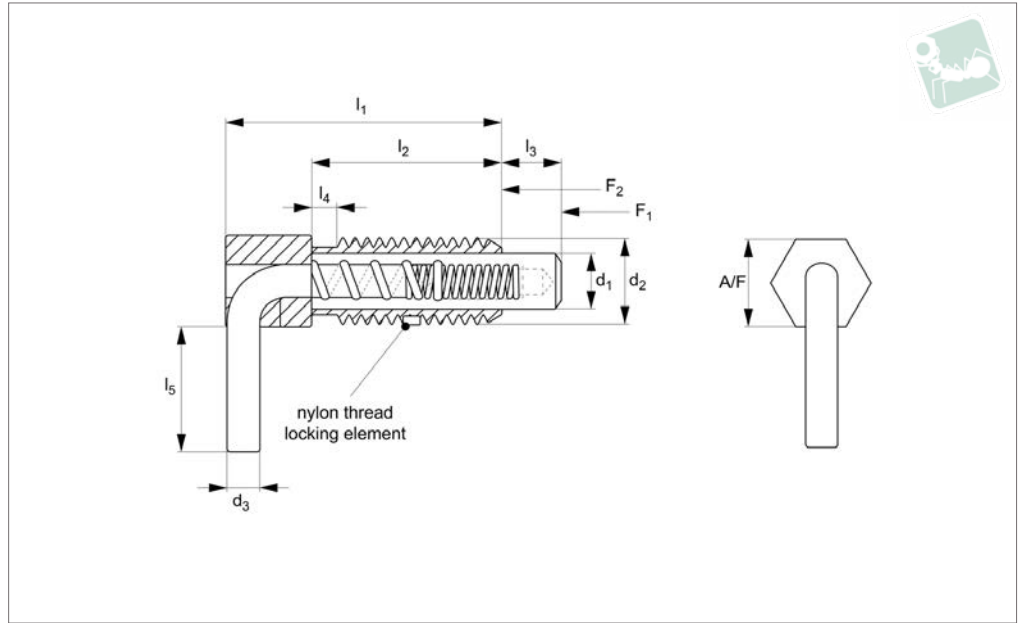

Material

Body and pin: steel 12L14, zinc plate clear chromate finish.

enable pin to be held in retracted/ non-projecting position. Pull back lever, turn 90° to engage ,locking’.

Tips

stubby version, for space limited applications. For suitable locknut, see part no. SL1816.

Technical Notes

Spring loaded pin can be „locked“ to

A nylon locking element on thread reduces chance of loosening of thread due to vibration etc.

Order No.	d ₁	d ₂ UNC	l ₁	l ₂	l ₃	l ₄	l ₅	d ₃	A/F	Spring force f ₁ lb	Spring force f ₂ lb
SL1218.I25-016-C	0.16	1/4-20	0.75	0.50	-	0.20	0.40	0.09	0.25	0.12	0.50
SL1218.I37-025-C	0.25	3/8-16	1.13	0.75	0.13	0.30	0.56	0.14	0.38	0.25	1.25
SL1218.I50-031-C	0.31	1/2-13	1.50	1.00	0.15	0.40	0.75	0.19	0.50	0.50	2.00
SL1218.I62-038-C	0.38	5/8-11	1.88	1.25	0.18	0.50	0.88	0.19	0.62	0.75	2.50

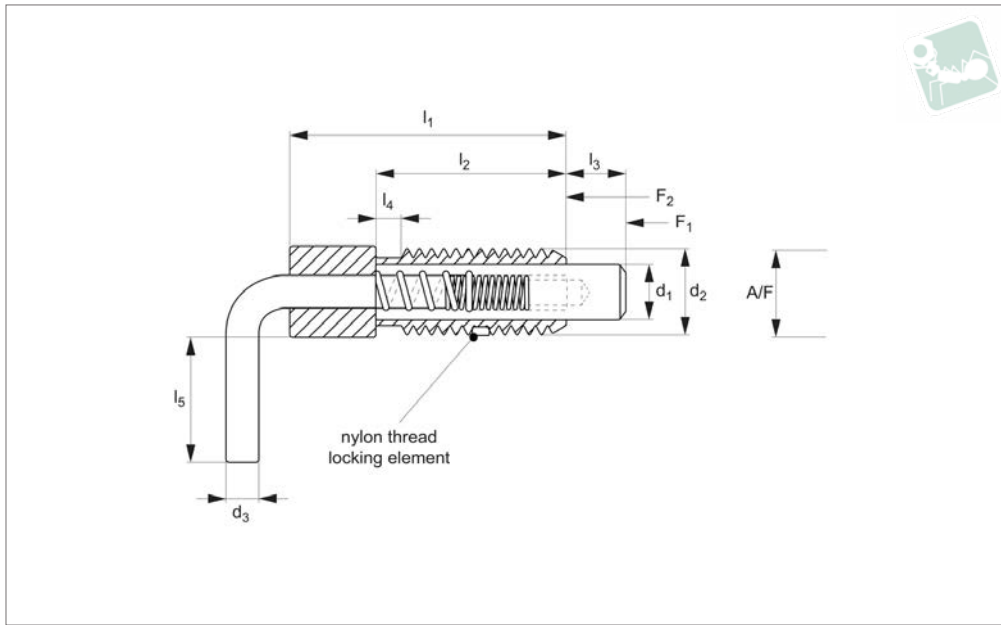

SL1216

SPRING LOADED PINS

Material

Body and pin: steel 12L14, zinc plate clear chromate finish.

simply springs back when lever released.

A nylon locking element on thread reduces chance of loosening of thread due to vibration etc.

Tips

Stubby version, for space limited applications.

For suitable locknut, see part no. SL1816.

Technical Notes

Spring loaded pin is non-locking, pin

Order No.	d ₁	d ₂ UNC	l ₁	l ₂	l ₃	l ₄	l ₅	d ₃	A/F	Spring force f ₁ lb	Spring force f ₂ lb
SL1216.I25-016-C	0.16	1/4-20	0.75	0.50	0.20	-	0.40	0.09	0.25	0.12	0.50
SL1216.I37-025-C	0.25	3/8-16	1.13	0.75	0.30	0.13	0.56	0.14	0.38	0.25	1.25
SL1216.I50-031-C	0.31	1/2-13	1.50	1.00	0.40	0.15	0.75	0.19	0.50	0.50	2.00
SL1216.I62-038-C	0.38	5/8-11	1.88	1.25	0.50	0.18	0.88	0.19	0.62	0.75	2.50



SL1318

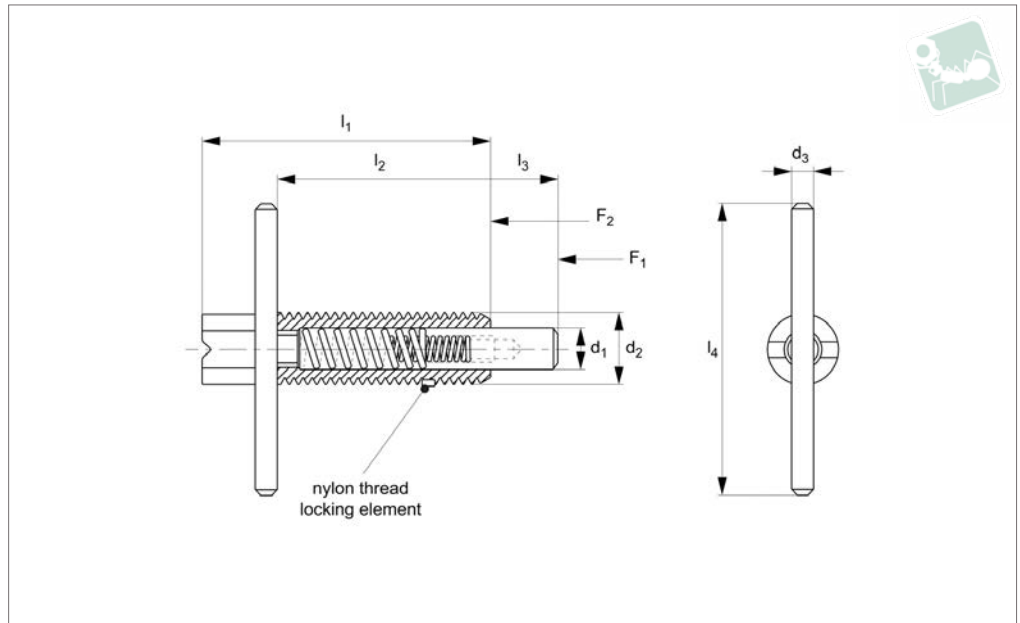

Material

Steel Type-

Body and pin: steel 12L14, zinc plate clear chromate finish.

Stainless Steel Type-

Body and pin: 300 series stainless steel.

Technical Notes

Spring loaded pin can be „locked“ to enable pin to be held in retracted/ non-projecting position. Pull back t-handle lever, turn 90° to engage ‚locking‘.

T-handle provides easy to use handle for a

more positive feel.

Tips

For suitable locknut, see part no. SL1816.

Order No.	Material	d ₁	d ₂ UNC	l ₁	l ₂	l ₃	l ₄	d ₃	Spring force f ₁ lb	Spring force f ₂ lb
SL1318.I25-015-C	Steel	0.15	1/4-20	1.14	0.8	0.250	1.13	0.13	1.0	2.5
SL1318.I37-023-C	Steel	0.23	3/8-16	1.68	1.2	0.375	1.50	0.13	2.0	4.0
SL1318.I50-031-C	Steel	0.31	1/2-13	2.00	1.4	0.500	2.00	0.16	2.0	5.0
SL1318.I62-037-C	Steel	0.37	5/8-11	2.38	1.7	0.625	2.50	0.19	2.5	5.0
SL1318.I25-015-S	Stainless	0.15	1/4-20	1.14	0.8	0.250	1.13	0.13	1.0	2.5
SL1318.I37-023-S	Stainless	0.23	3/8-16	1.68	1.2	0.375	1.50	0.13	2.0	4.0
SL1318.I50-031-S	Stainless	0.31	1/2-13	2.00	1.4	0.500	2.00	0.16	2.0	5.0
SL1318.I62-037-S	Stainless	0.37	5/8-11	2.38	1.7	0.625	2.50	0.19	2.5	5.0



Spring Loaded Pin - Inch - T-Handle non-locking

Spring Loaded Pins

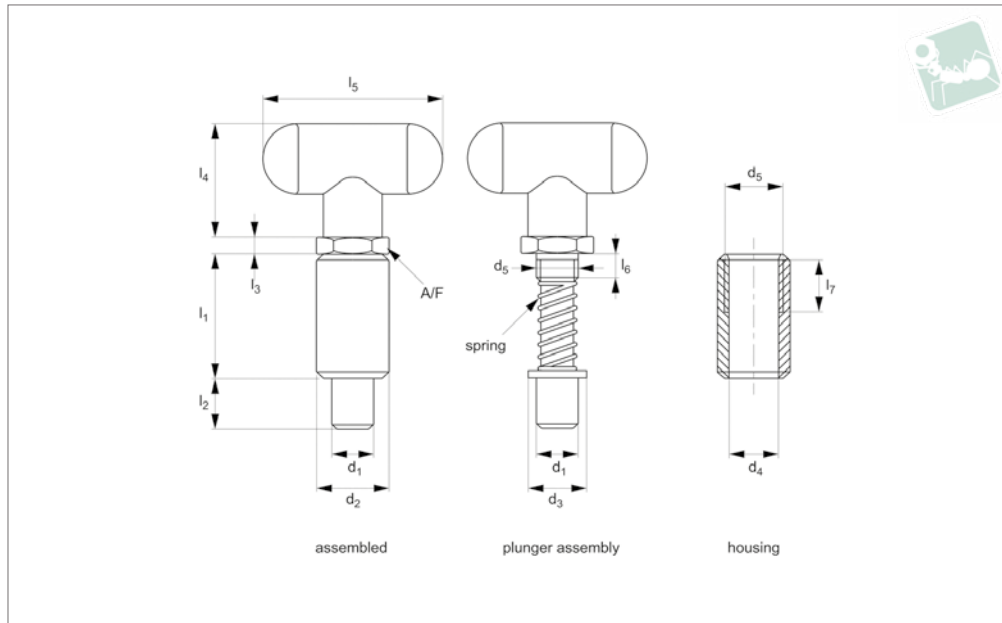

SL2016

SPRING LOADED PINS

Material

Steel Type-

Housing: Steel C1038, not plated.

Plunger assembly: Steel C1038, zinc plated.

Handle: Thermoplastic, black.

Stainless Steel Type-

Housing: Stainless Steel AISI 303.

Plunger assembly: Stainless Steel AISI 303.

Handle: Thermoplastic, black.

Aluminium Type-

Housing: aluminium 6061-T6.

Plunger assembly: Steel C1038, zinc plated.

Handle: Thermoplastic, black.

Technical Notes

Force required to lift handle approx. 2,5Kg.

For both the steel and aluminium plungers, tensile strength is 620 N/mm² except for largest pin size being 400 N/mm².

Tips

Housing and plunger assembly supplied as separate elements, this allows housing to be welded in place without damage to plastic handle of plunger assembly. Spring loaded pin is non-locking, pin simply springs back when lever released.

Order No.	Material	d ₁	d ₂	l ₁	l ₂	l ₃	l ₄	l ₅	l ₆	l ₇	d ₃	d ₄	d ₅	A/F
		+0.05 -0.1	+0.00 -0.12											
SL2016.I25-150-C	Steel	6,35 (1/4")	25.40	38.1	14.3	4.75	36.5	57.1	11.2	21.9	16.15	16.5	3/4"-10	22.3
SL2016.I37-150-C	Steel	9,53 (3/8")	25.40	38.1	14.3	4.75	36.5	57.1	11.2	21.9	16.15	16.5	3/4"-10	22.3
SL2016.I50-150-C	Steel	12,70 (1/2")	25.40	38.1	14.3	4.75	36.5	57.1	11.2	21.9	16.15	16.5	3/4"-10	22.3
SL2016.I50-225-C	Steel	12,70 (1/2")	25.40	57.1	14.3	4.75	36.5	57.1	11.2	21.9	16.15	16.5	3/4"-10	22.3
SL2016.I62-225-C	Steel	15,87 (5/8")	25.40	57.1	14.3	4.75	36.5	57.1	11.2	21.9	16.15	16.5	3/4"-10	22.3
SL2016.I25-150-A	Aluminium	6,35 (1/4")	25.40	38.1	14.3	4.75	36.5	57.1	11.2	21.9	16.15	16.5	3/4"-10	22.3
SL2016.I37-150-A	Aluminium	9,53 (3/8")	25.40	38.1	14.3	4.75	36.5	57.1	11.2	21.9	16.15	16.5	3/4"-10	22.3
SL2016.I50-150-A	Aluminium	12,70 (1/2")	25.40	38.1	14.3	4.75	36.5	57.1	11.2	21.9	16.15	16.5	3/4"-10	22.3
SL2016.I50-225-A	Aluminium	12,70 (1/2")	25.40	57.1	14.3	4.75	36.5	57.1	11.2	21.9	16.15	16.5	3/4"-10	22.3
SL2016.I62-225-A	Aluminium	15,87 (5/8")	25.40	57.1	14.3	4.75	36.5	57.1	11.2	21.9	16.15	16.5	3/4"-10	22.3
SL2016.I37-150-S	Stainless	9,53 (3/8")	25.40	38.1	14.3	4.75	36.5	57.1	11.2	21.9	16.15	16.5	3/4"-10	22.3
SL2016.I50-150-S	Stainless	12,70 (1/2")	25.40	38.1	14.3	4.75	36.5	57.1	11.2	21.9	16.15	16.5	3/4"-10	22.3
SL2016.I50-225-S	Stainless	12,70 (1/2")	25.40	57.1	14.3	4.75	36.5	57.1	11.2	21.9	16.15	16.5	3/4"-10	22.3



SL2018

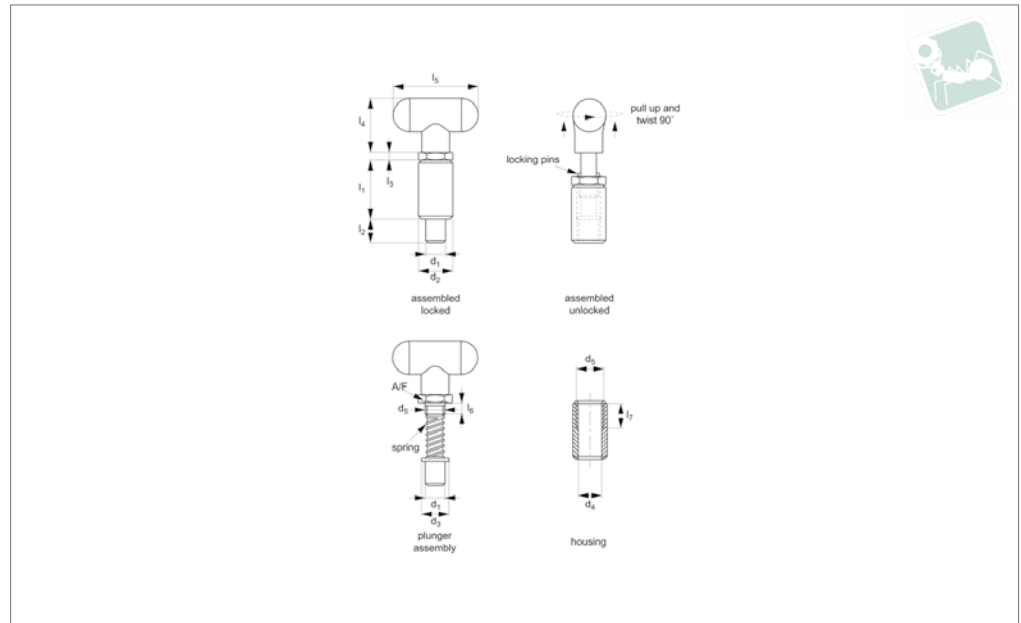

Material

Steel Type-

Housing: Steel C1038, not plated.
Plunger assembly: Steel C1038, zinc plated.
Handle: Thermoplastic, black.

Stainless Steel Type-

Housing: Stainless Steel AISI 303.
Plunger assembly: Stainless Steel AISI 303.
Handle: Thermoplastic, black.

Aluminium Type-

Housing: aluminium 6061-T6.

Plunger assembly: Steel C1038, zinc plated.

Handle: Thermoplastic, black.

Technical Notes

Force required to lift handle approx. 2,5Kg.

For both the steel and aluminium plungers, tensile strength is 620 N/mm² except for largest pin size being 400 N/mm².

Tips

Housing and plunger assembly supplied as

separate elements, this allows housing to be welded in place without damage to plastic handle of plunger assembly. Spring loaded pin can be „locked“ to enable pin to be held in retracted/ non-projecting position. Pull back lever, turn 90° to engage „locking“.

Order No.	Material	d ₁ +0.05 -0.1	d ₂ +0.00 -0.12	l ₁	l ₂	l ₃	l ₄	l ₅	l ₆	l ₇	d ₃	d ₄	d ₅	A/F
SL2018.I25-150-C	Steel	6,35 (1/4")	25.40	38.1	14.3	4.75	36.5	57.1	11.2	21.9	16.15	16.5	3/4"-10	22.3
SL2018.I37-150-C	Steel	9,53 (3/8")	25.40	38.1	14.3	4.75	36.5	57.1	11.2	21.9	16.15	16.5	3/4"-10	22.3
SL2018.I50-150-C	Steel	12,70 (1/2")	25.40	38.1	14.3	4.75	36.5	57.1	11.2	21.9	16.15	16.5	3/4"-10	22.3
SL2018.I50-225-C	Steel	12,70 (1/2")	25.40	57.1	14.3	4.75	36.5	57.1	11.2	21.9	16.15	16.5	3/4"-10	22.3
SL2018.I62-225-C	Steel	15,87 (5/8")	25.40	57.1	14.3	4.75	36.5	57.1	11.2	21.9	16.15	16.5	3/4"-10	22.3
SL2018.I25-150-A	Aluminium	6,35 (1/4")	25.40	38.1	14.3	4.75	36.5	57.1	11.2	21.9	16.15	16.5	3/4"-10	22.3
SL2018.I37-150-A	Aluminium	9,53 (3/8")	25.40	38.1	14.3	4.75	36.5	57.1	11.2	21.9	16.15	16.5	3/4"-10	22.3
SL2018.I50-150-A	Aluminium	12,70 (1/2")	25.40	38.1	14.3	4.75	36.5	57.1	11.2	21.9	16.15	16.5	3/4"-10	22.3
SL2018.I50-225-A	Aluminium	12,70 (1/2")	25.40	57.1	14.3	4.75	36.5	57.1	11.2	21.9	16.15	16.5	3/4"-10	22.3
SL2018.I62-225-A	Aluminium	15,87 (5/8")	25.40	57.1	14.3	4.75	36.5	57.1	11.2	21.9	16.15	16.5	3/4"-10	22.3
SL2018.I37-150-S	Stainless	9,53 (3/8")	25.40	38.1	14.3	4.75	36.5	57.1	11.2	21.9	16.15	16.5	3/4"-10	22.3
SL2018.I50-150-S	Stainless	12,70 (1/2")	25.40	38.1	14.3	4.75	36.5	57.1	11.2	21.9	16.15	16.5	3/4"-10	22.3
SL2018.I50-225-S	Stainless	12,70 (1/2")	25.40	57.1	14.3	4.75	36.5	57.1	11.2	21.9	16.15	16.5	3/4"-10	22.3

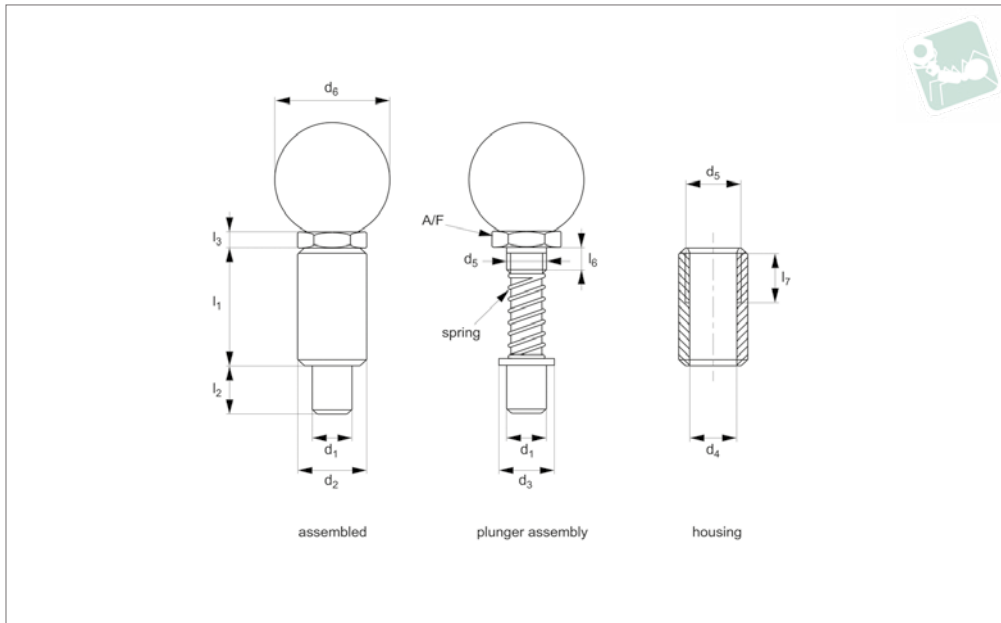

SL2116

SPRING LOADED PINS

Material

Steel Type-

Housing: Steel C1038, not plated.

Plunger assembly: Steel C1038, zinc plated.

Handle: Thermoplastic, black.

Stainless Steel Type-

Housing: Stainless Steel AISI 303.

Plunger assembly: Stainless Steel AISI 303.

Handle: Thermoplastic, black.

Aluminium Type-

Housing: aluminium 6061-T6.

Plunger assembly: Steel C1038, zinc plated.

Handle: Thermoplastic, black.

Technical Notes

Force required to lift handle approx. 2,5Kg.

For both the steel and aluminium plungers, tensile strength is 620 N/mm² except for largest pin size being 400 N/mm².

Tips

Housing and plunger assembly supplied as separate elements, this allows housing to be welded in place without damage to plastic handle of plunger assembly. Spring loaded pin is non-locking, pin simply springs back when lever released.

Order No.	Material	d ₁ +0.05 -0.1	d ₂ +0.00 -0.12	l ₁	l ₂	l ₃	l ₆	l ₇	d ₃	d ₄	d ₅	d ₆	A/F
SL2116.I25-150-C	Steel	6,35 (1/4")	25.40	38.1	14.3	4.75	11.2	21.9	16.15	16.5	3/4"-10	35.0	22.3
SL2116.I37-150-C	Steel	9,53 (3/8")	25.40	38.1	14.3	4.75	11.2	21.9	16.15	16.5	3/4"-10	35.0	22.3
SL2116.I50-150-C	Steel	12,70 (1/2")	25.40	38.1	14.3	4.75	11.2	21.9	16.15	16.5	3/4"-10	35.0	22.3
SL2116.I50-225-C	Steel	12,70 (1/2")	25.40	57.1	14.3	4.75	11.2	21.9	16.15	16.5	3/4"-10	35.0	22.3
SL2116.I62-225-C	Steel	15,87 (5/8")	25.40	57.1	14.3	4.75	11.2	21.9	16.15	16.5	3/4"-10	35.0	22.3
SL2116.I25-150-A	Aluminium	6,35 (1/4")	25.40	38.1	14.3	4.75	11.2	21.9	16.15	16.5	3/4"-10	35.0	22.3
SL2116.I37-150-A	Aluminium	9,53 (3/8")	25.40	38.1	14.3	4.75	11.2	21.9	16.15	16.5	3/4"-10	35.0	22.3
SL2116.I50-150-A	Aluminium	12,70 (1/2")	25.40	38.1	14.3	4.75	11.2	21.9	16.15	16.5	3/4"-10	35.0	22.3
SL2116.I50-225-A	Aluminium	12,70 (1/2")	25.40	57.1	14.3	4.75	11.2	21.9	16.15	16.5	3/4"-10	35.0	22.3
SL2116.I62-225-A	Aluminium	15,87 (5/8")	25.40	57.1	14.3	4.75	11.2	21.9	16.15	16.5	3/4"-10	35.0	22.3
SL2116.I37-150-S	Stainless	9,53 (3/8")	25.40	38.1	14.3	4.75	11.2	21.9	16.15	16.5	3/4"-10	35.0	22.3
SL2116.I50-150-S	Stainless	12,70 (1/2")	25.40	38.1	14.3	4.75	11.2	21.9	16.15	16.5	3/4"-10	35.0	22.3
SL2116.I50-225-S	Stainless	12,70 (1/2")	25.40	57.1	14.3	4.75	11.2	21.9	16.15	16.5	3/4"-10	35.0	22.3



SL2118

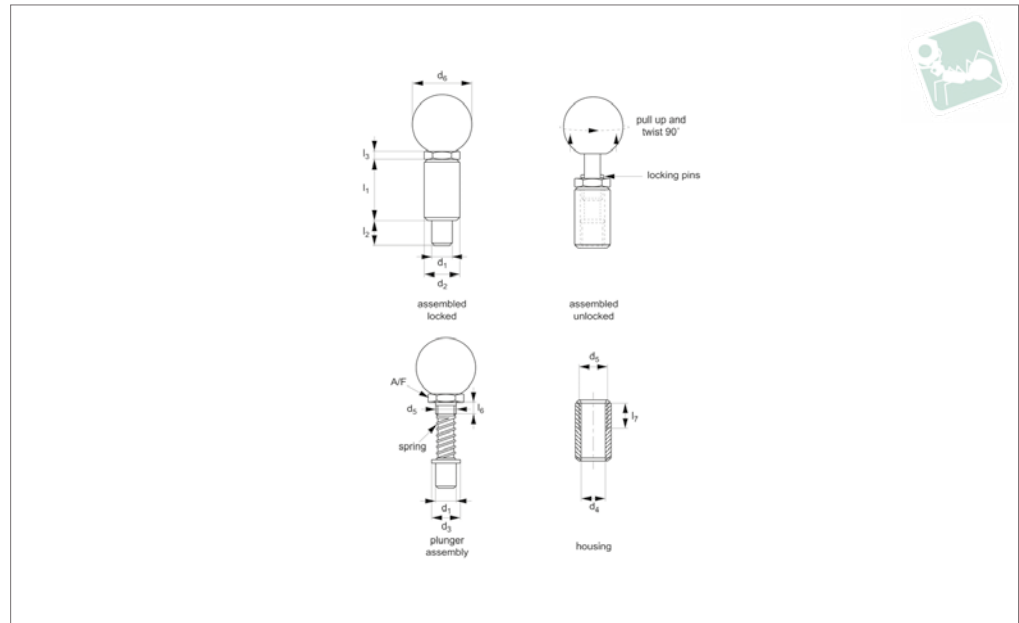

Material

Steel Type-

Housing: Steel C1038, not plated.
Plunger assembly: Steel C1038, zinc plated.
Handle: Thermoplastic, black.

Stainless Steel Type-

Housing: Stainless Steel AISI 303.
Plunger assembly: Stainless Steel AISI 303.
Handle: Thermoplastic, black.

Aluminium Type-

Housing: aluminium 6061-T6.

Plunger assembly: Steel C1038, zinc plated.

Handle: Thermoplastic, black.

Technical Notes

Force required to lift handle approx. 2,5Kg.

For both the steel and aluminium plungers, tensile strength is 620 N/mm² except for largest pin size being 400 N/mm².

Tips

Housing and plunger assembly supplied as separate elements, this allows housing to be welded in place without damage to plastic handle of plunger assembly. Spring loaded pin can be „locked“ to enable pin to be held in retracted/ non-projecting position. Pull back lever, turn 90° to engage ‚locking‘.

Order No.	Material	d ₁ +0.05 -0.1	d ₂ +0.00 -0.12	l ₁	l ₂	l ₃	l ₆	l ₇	d ₃	d ₄	d ₅	d ₆	A/F
SL2118.I25-150-C	Steel	6,35 (1/4")	25.40	38.1	14.3	4.75	11.2	21.9	16.15	16.5	3/4"-10	35.0	22.3
SL2118.I37-150-C	Steel	9,53 (3/8")	25.40	38.1	14.3	4.75	11.2	21.9	16.15	16.5	3/4"-10	35.0	22.3
SL2118.I50-150-C	Steel	12,70 (1/2")	25.40	38.1	14.3	4.75	11.2	21.9	16.15	16.5	3/4"-10	35.0	22.3
SL2118.I50-225-C	Steel	12,70 (1/2")	25.40	57.1	14.3	4.75	11.2	21.9	16.15	16.5	3/4"-10	35.0	22.3
SL2118.I62-225-C	Steel	15,87 (5/8")	25.40	57.1	14.3	4.75	11.2	21.9	16.15	16.5	3/4"-10	35.0	22.3
SL2118.I25-150-A	Aluminium	6,53 (1/4")	25.40	38.1	14.3	4.75	11.2	21.9	16.15	16.5	3/4"-10	35.0	22.3
SL2118.I37-150-A	Aluminium	9,53 (3/8")	25.40	38.1	14.3	4.75	11.2	21.9	16.15	16.5	3/4"-10	35.0	22.3
SL2118.I50-150-A	Aluminium	12,70 (1/2")	25.40	38.1	14.3	4.75	11.2	21.9	16.15	16.5	3/4"-10	35.0	22.3
SL2118.I50-225-A	Aluminium	12,70 (1/2")	25.40	57.1	14.3	4.75	11.2	21.9	16.15	16.5	3/4"-10	35.0	22.3
SL2118.I62-225-A	Aluminium	15,87 (5/8")	25.40	57.1	14.3	4.75	11.2	21.9	16.15	16.5	3/4"-10	35.0	22.3
SL2118.I37-150-S	Stainless	9,53 (3/8")	25.40	38.1	14.3	4.75	11.2	21.9	16.15	16.5	3/4"-10	35.0	22.3
SL2118.I50-150-S	Stainless	12,70 (1/2")	25.40	38.1	14.3	4.75	11.2	21.9	16.15	16.5	3/4"-10	35.0	22.3
SL2118.I50-225-S	Stainless	12,70 (1/2")	25.40	57.1	14.3	4.75	11.2	21.9	16.15	16.5	3/4"-10	35.0	22.3



Spring Loaded Pin - Inch - Threaded non-locking

Spring Loaded Pins

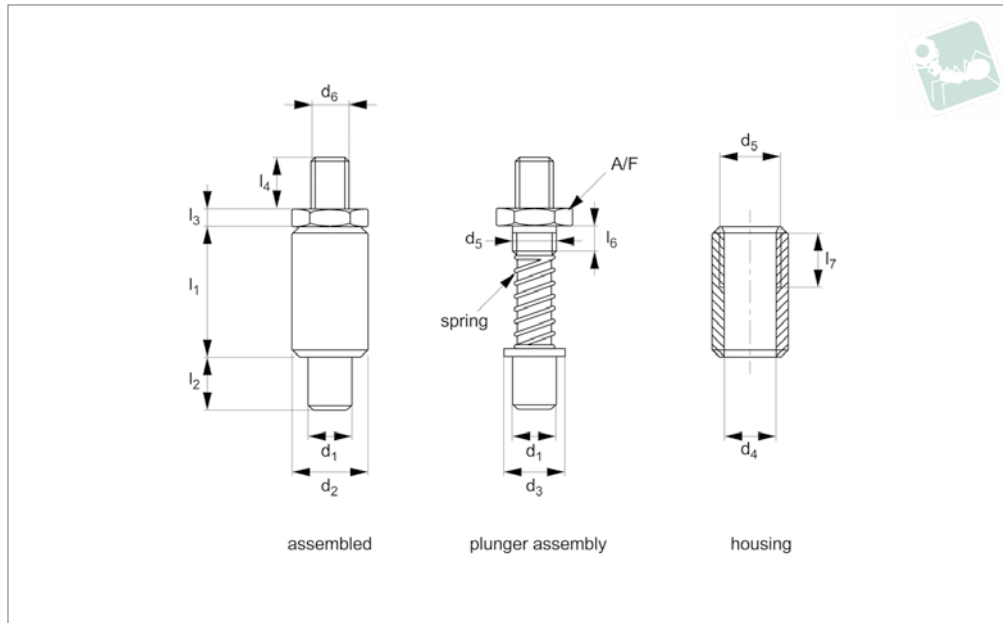

SL2216

SPRING LOADED PINS

Material

Steel Type-

Housing: Steel C1038, not plated.

Plunger assembly: Steel C1038, zinc plated.

Stainless Steel Type-

Housing: Stainless Steel AISI 303.

Plunger assembly: Stainless Steel AISI 303.

Aluminium Type-

Housing: aluminium 6061-T6.

Plunger assembly: Steel C1038, zinc plated.

Technical Notes

Force required to lift handle approx. 2,5Kg.

For both the steel and aluminium plungers, tensile strength is 620 N/mm² except for largest pin size being 400 N/mm².

Tips

Housing and plunger assembly supplied as separate elements, this allows housing to be welded in place without damage to plastic handle of plunger assembly. Spring loaded pin is non-locking, pin simply springs back when lever released.

Order No.	Material	d ₁ +0.05 -0.1	d ₂ +0.00 -0.12	l ₁	l ₂	l ₃	l ₄	l ₆	l ₇	d ₃	d ₄	d ₅	d ₆	A/F
SL2216.I25-150-C	Steel	6,35 (1/4")	25.40	38.1	14.3	4.75	36.5	11.2	21.9	16.15	16.5	3/4"-10	3/8"-16	22.3
SL2216.I37-150-C	Steel	9,53 (3/8")	25.40	38.1	14.3	4.75	36.5	11.2	21.9	16.15	16.5	3/4"-10	3/8"-16	22.3
SL2216.I50-150-C	Steel	12,70 (1/2")	25.40	38.1	14.3	4.75	36.5	11.2	21.9	16.15	16.5	3/4"-10	3/8"-16	22.3
SL2216.I50-225-C	Steel	12,70 (1/2")	25.40	57.1	14.3	4.75	36.5	11.2	21.9	16.15	16.5	3/4"-10	3/8"-16	22.3
SL2216.I62-225-C	Steel	15,87 (5/8")	25.40	57.1	14.3	4.75	36.5	11.2	21.9	16.15	16.5	3/4"-10	3/8"-16	22.3
SL2216.I25-150-A	Aluminium	6,35 (1/4")	25.40	38.1	14.3	4.75	36.5	11.2	21.9	16.15	16.5	3/4"-10	3/8"-16	22.3
SL2216.I37-150-A	Aluminium	9,53 (3/8")	25.40	38.1	14.3	4.75	36.5	11.2	21.9	16.15	16.5	3/4"-10	3/8"-16	22.3
SL2216.I50-150-A	Aluminium	12,70 (1/2")	25.40	38.1	14.3	4.75	36.5	11.2	21.9	16.15	16.5	3/4"-10	3/8"-16	22.3
SL2216.I50-225-A	Aluminium	12,70 (1/2")	25.40	57.1	14.3	4.75	36.5	11.2	21.9	16.15	16.5	3/4"-10	3/8"-16	22.3
SL2216.I62-225-A	Aluminium	15,87 (5/8")	25.40	57.1	14.3	4.75	36.5	11.2	21.9	16.15	16.5	3/4"-10	3/8"-16	22.3
SL2216.I37-150-S	Stainless	9,53 (3/8")	25.40	38.1	14.3	4.75	36.5	11.2	21.9	16.15	16.5	3/4"-10	3/8"-16	22.3
SL2216.I50-150-S	Stainless	12,70 (1/2")	25.40	38.1	14.3	4.75	36.5	11.2	21.9	16.15	16.5	3/4"-10	3/8"-16	22.3
SL2216.I50-225-S	Stainless	12,70 (1/2")	25.40	57.1	14.3	4.75	36.5	11.2	21.9	16.15	16.5	3/4"-10	3/8"-16	22.3



SL2316

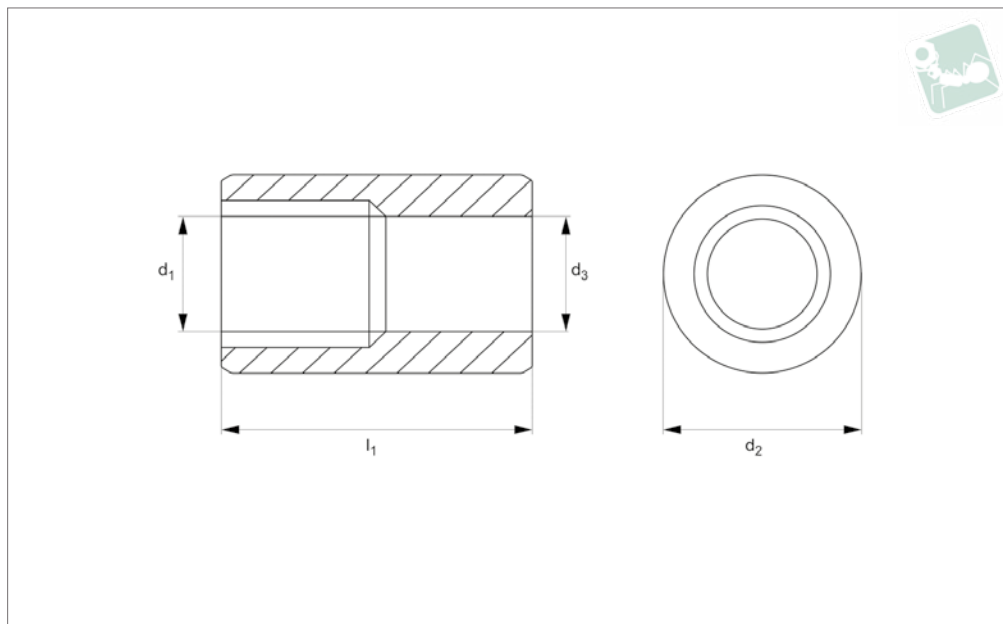

Material

Steel Type -

Steel, C1038, un-plated, aluminium 6061-T6.

Stainless Steep Type-

Stainless steel (AISI 303).

Technical Notes

Spare housing bodies. For spring loaded pins S to SL2216.

Order No.	Material	d_1 +0.00 -0.12	d_2	l_1	l_2	d_3
SL2316.075-150-C	Steel	3/4"-10	25.4	38.1	21.9	16.5
SL2316.075-250-C	Steel	3/4"-10	25.4	57.1	21.9	16.5
SL2316.075-150-A	Aluminium	3/4"-10	25.4	38.1	21.9	16.5
SL2316.075-250-A	Aluminium	3/4"-10	25.4	57.1	21.9	16.5
SL2316.075-150-S	Stainless	3/4"-10	25.4	38.1	21.9	16.5
SL2316.075-250-S	Stainless	3/4"-10	25.4	57.1	21.9	16.5



Spring Loaded Pin - Adjustable

inch - grip handle, weldable

Spring Loaded Pins

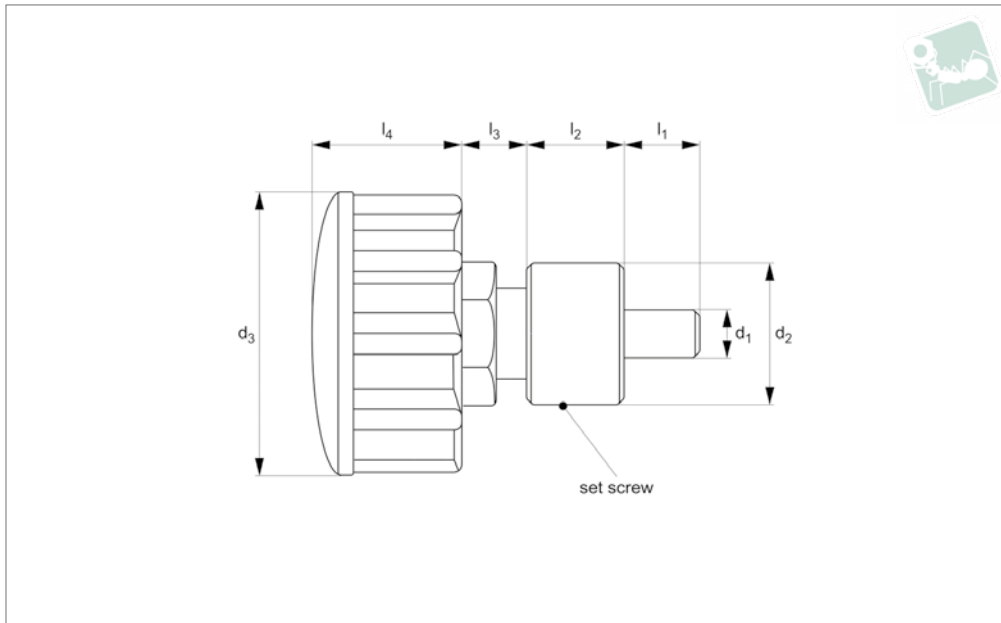

SL2516

SPRING LOADED PINS

Material

Housing: Steel, 12L15, un-plated.
 Plunger assembly: Steel, 1038, zinc plated.
 Handle: Thermoplastic

Technical Notes

Ideal for applications where there is a

variance in the part being held. Once the pin is engaged, turning the knob allows the pin to tighten down on the work piece or further extend the plunger into the locating hole.

The set screw on the housing allows you to

lock the plunger at a set depth for repeated operations and prevents the mechanism from coming out of the housing.

Order No.	d ₁ +0.05 -0.10	d ₂	l ₁	l ₂	l ₃	l ₄	d ₃	Adjustment
SL2516.025-143-C	6,35 (1/4")	28.5	14.3	19.0	12.7	28.58	57.1	15.8
SL2516.037-143-C	9,53 (3/8")	28.5	14.3	19.0	12.7	28.58	57.1	15.8
SL2516.050-143-C	12,7 (1/2")	28.5	14.3	19.0	12.7	28.58	57.1	15.8



SL2610

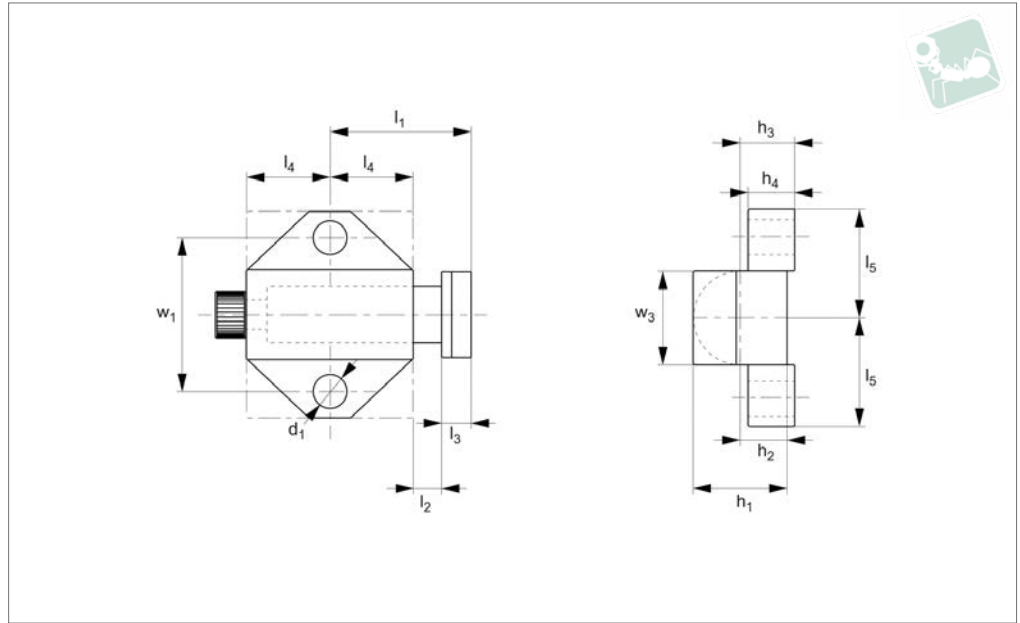

Material

Body: Aluminium.
Nose: Steel 12L14.

clamping.

Tips

Ideal for holding and securing parts while

Order No.	Mounting base	d ₁	l ₁	l ₂	l ₃	l ₄	l ₅	h ₁	h ₂	h ₃	h ₄	w ₁	w ₃	Spring force f ₁ N	Spring force f ₂ N
SL2610.I12-043-A	Triangle	3.25	15.1	3.18	3.18	8.73	11.1	9.53	4.76	5.56	4.76	16.7	9.53	22.25	66.80
SL2610.I18-075-A	Square	4.90	23.8	4.76	6.35	12.7	19.1	15.9	7.94	5.56	6.35	28.6	15.9	8.900	115.7
SL2610.I25-100-A	Square	6.53	31.8	6.35	7.94	14.5	25.4	19.1	9.53	13.4	7.94	38.1	19.1	71.20	213.6



Spring Stop - Inch round nose

Spring Loaded Pins

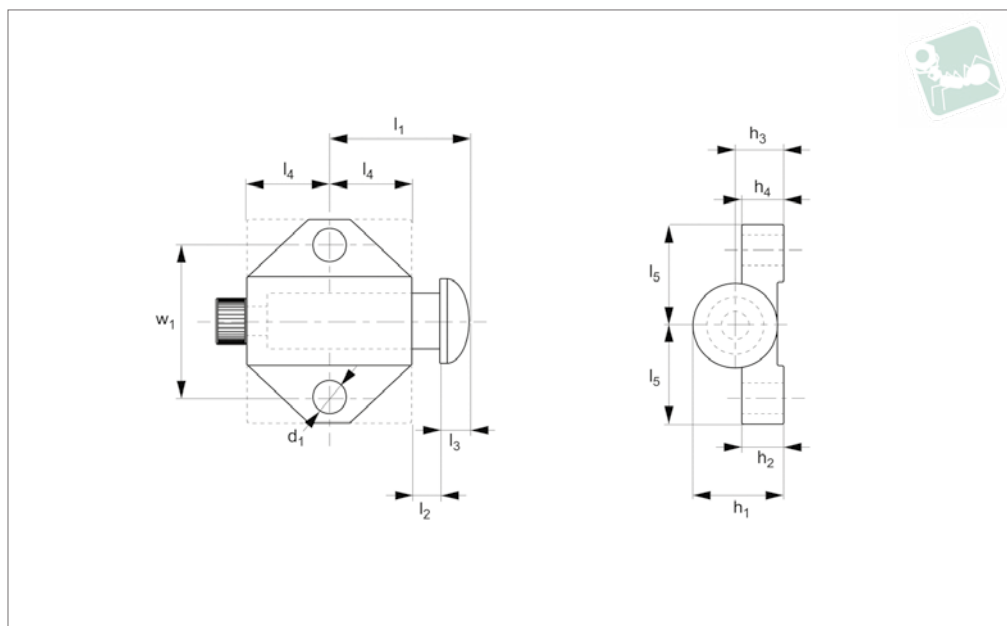

SL2615

SPRING LOADED PINS

Material

Body: Aluminium.
Nose: Steel 12L14.

clamping.

Tips

Ideal for holding and securing parts while

Order No.	Mounting base	d ₁	l ₁	l ₂	l ₃	l ₄	l ₅	h ₃	h ₄	h ₅ mm	w ₁	w ₂	Spring force f ₁ N	Spring force f ₂ N
SL2615.I12-043-A	Triangle	3.25	15.08	3.18	3.18	8.73	11.1	5.56	4.76	5.55	16.67	9.53	22.3	66.75
SL2615.I18-075-A	Square	4.90	23.81	4.76	4.76	12.7	19.1	7.94	6.35	22.22	28.58	14.29	8.90	115.7
SL2615.I25-100-A	Square	6.53	29.77	6.35	6.35	17.5	25.4	13.5	7.94	34.13	38.10	20.64	71.2	213.6