

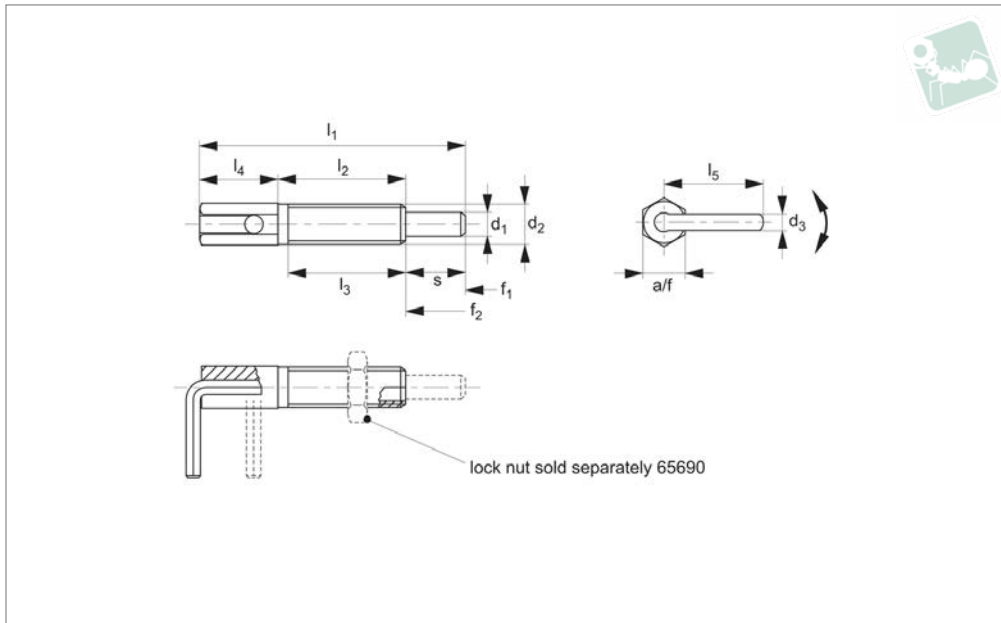

Index Plungers - Lever Grip

locking - coarse thread

Spring Loaded Pins



SL1112

SPRING LOADED PINS

Material

Body: free cutting steel, zinc plated.
Pin: steel, galvanised.
Lever: steel, galvanised.

Technical Notes

Pull back and turn lever 180° to retract pin.

To enable pin to be held in retracted position, secure lever in notched catch on plunger body.
For applications where high precision is not required.
Coarse thread.

Temperature resistance up to 250°C

Lock nuts sold separately. See product 65690.

Tips

Spring loads* = statistical average.

Order No.	Type	d ₁	d ₂	d ₃	l ₁	l ₂	l ₃	l ₄	l ₅	s	A/F	Spring load F ₁ N ≈	Spring load F ₂ N ≈	Tightening torque Nm max.	Weight g
SL1112.M06-004-C	Locking	4	M 6x1,00	2,3	41,5	20,0	17,0	12,0	15,5	9,5	6	3,0	10,0	1,6	6
SL1112.M08-005-C	Locking	5	M 8x1,25	3,0	54,0	27,0	24,0	15,0	19,2	12,0	8	3,5	13,5	4,5	14
SL1112.M10-006-C	Locking	6	M10x1,50	3,5	65,0	33,5	30,0	17,5	22,9	14,0	10	4,0	16,0	10,0	26
SL1112.M12-008-C	Locking	8	M12x1,75	4,7	73,0	31,8	28,0	22,2	31,2	19,0	12	4,0	22,0	13,0	55
SL1112.M16-010-C	Locking	10	M16x2,00	4,7	102,5	50,5	44,5	27,0	32,7	25,0	16	4,0	23,0	42,0	103



SL1113

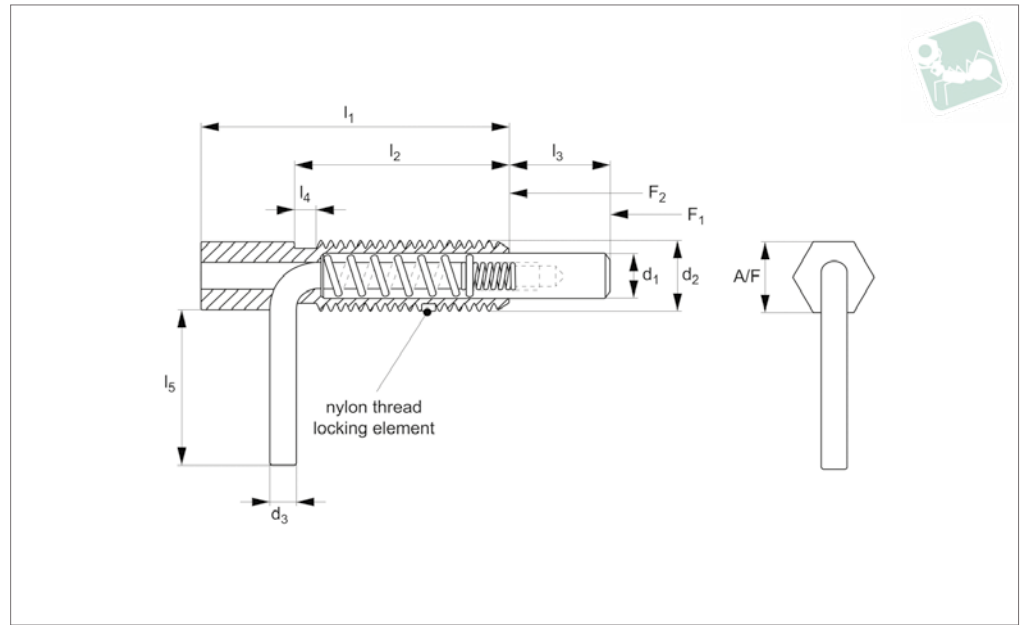

Material

Steel Type-

Body and pin: steel 12L14, zinc plate clear chromate finish.

Stainless Steel Type -

Body and pin: 300 series stainless steel.

Technical Notes

Spring loaded pin can be „locked“ to enable pin to be held in retracted/ non-projecting position. Pull back lever, turn 90° to engage ‚locking‘.

A nylon locking element on thread reduces

chance of loosening of thread due to vibration etc.

Tips

For suitable locknut, see part no. SL1810.

Order No.	Material	d ₁	d ₂ tol. 5g	l ₁	l ₂	l ₃	l ₄	l ₅	d ₃	Spring force f ₁ N	Spring force f ₂ N
SL1113.M06-004-C	Steel	4	M 6 x 1,00	32	20	10	-	12.7	2.3	2.2	11.1
SL1113.M10-006-C	Steel	6	M10 x 1,50	51	33	14	3.3	19.0	3.5	3.3	16.7
SL1113.M12-007-C	Steel	7	M12 x 1,75	54	32	19	3.8	25.4	4.8	4.5	22.2
SL1113.M06-004-S	Stainless Steel	4	M 6 x 1,00	32	20	10	-	12.7	2.3	2.2	11.1
SL1113.M10-006-S	Stainless Steel	6	M10 x 1,50	51	33	14	3.3	19.0	3.5	3.3	16.7
SL1113.M12-007-S	Stainless Steel	7	M12 x 1,75	54	32	19	3.8	25.4	4.8	4.5	22.2
SL1113.M08-005-C	Locking	5	M 8x1,25	3.0	54.0	27.0	24.0	15.0	19.2	3.5	14
SL1113.M16-010-C	Locking	10	M16x2,00	4.7	102.5	50.5	44.5	27.0	32.7	4.0	103



Spring Loaded Pin - Inch - Lever non-locking

Spring Loaded Pins

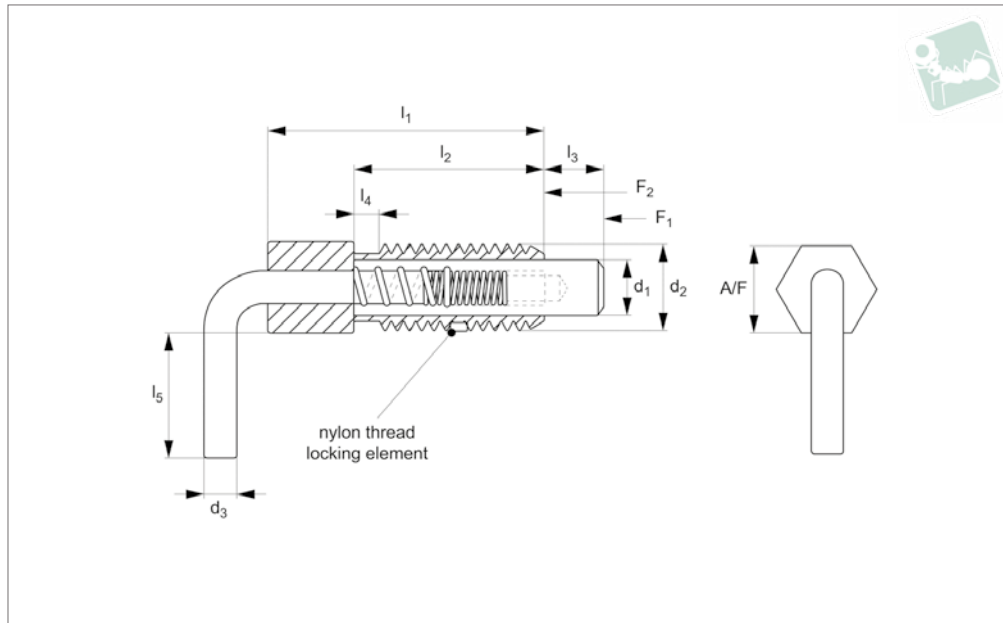

SL1116

SPRING LOADED PINS

Material

Body and pin: steel 12L14.

simply springs back when lever released.

Tips

For suitable locknut, see part no. SL1816.

Technical Notes

Spring loaded pin is non-locking, pin

A nylon locking element on thread reduces chance of loosening of thread due to vibration etc.

Order No.	d ₁	d ₂ UNC	l ₁	l ₂	l ₃	l ₄	l ₅	d ₃	A/F	Spring force f ₁ lb	Spring force f ₂ lb
SL1116.I25-016-C	0.16	1/4-20	1.25	0.80	0.38	-	0.50	0.09	0.25	0.50	2.50
SL1116.I37-025-C	0.25	3/8-16	2.00	1.31	0.56	0.13	0.75	0.14	0.38	0.38	3.75
SL1116.I50-031-C	0.31	1/2-13	2.00	1.25	0.75	0.15	1.00	0.19	0.50	1.00	5.00
SL1116.I62-038-C	0.38	5/8-11	3.05	2.00	1.00	0.18	1.00	0.19	0.62	1.00	5.00

Spring Loaded Pins

Spring Loaded Pin - Inch - Lever locking



SPRING LOADED PINS



SL1118

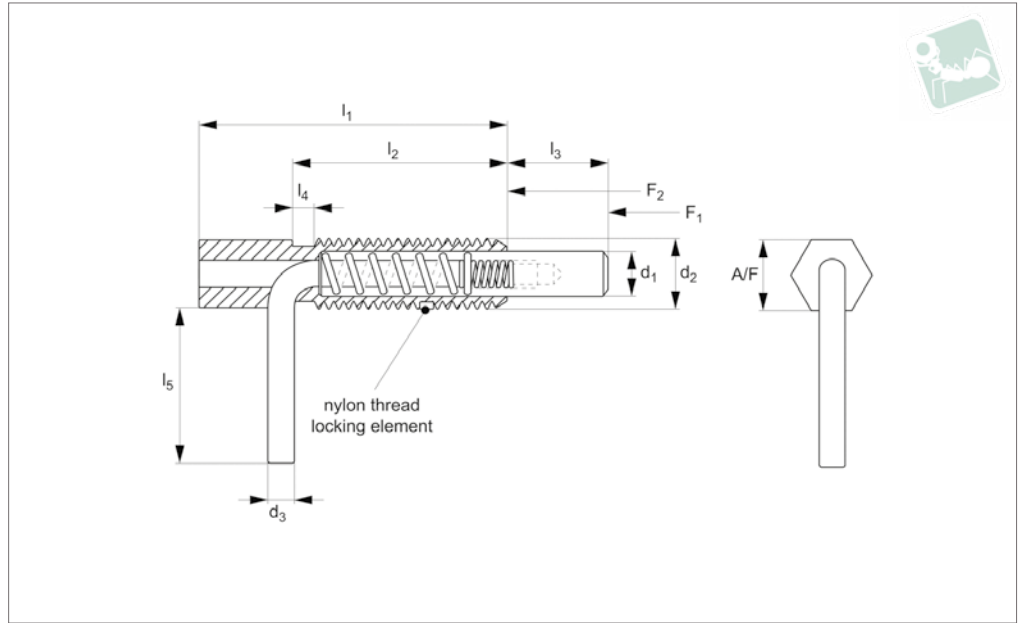

Material

Steel Type-

Body and pin: steel 12L14, zinc plate clear chromate finish.

Stainless Steel Type -

Body and pin: 300 series stainless steel.

Technical Notes

Spring loaded pin can be „locked“ to enable pin to be held in retracted/ non-projecting position. Pull back lever, turn 90° to engage ‚locking‘.

A nylon locking element on thread reduces

chance of loosening of thread due to vibration etc.

Tips

For suitable locknut, see part no. SL1816.

Order No.	Material	d ₁	d ₂ UNC	l ₁	l ₂	l ₃	l ₄	l ₅	d ₃	Spring force f ₁ lb	Spring force f ₂ lb	Weight g
SL1118.I25-016-C	Steel	0.16	1/4-20	1.25	0.80	0.38	-	0.50	0.09	0.50	2.50	9.0
SL1118.I37-023-C	Steel	0.23	3/8-16	2.00	1.31	0.56	0.13	0.75	0.14	0.75	3.75	22.5
SL1118.I50-031-C	Steel	0.31	1/2-13	2.11	1.25	0.75	0.15	0.93	0.19	1.00	5.00	45.0
SL1118.I62-038-C	Steel	0.38	5/8-11	3.05	2.00	1.00	0.18	1.00	0.19	1.00	5.00	67.5
SL1118.I25-016-S	Stainless	0.16	1/4-20	1.25	0.80	0.38	-	0.50	0.09	0.50	2.50	9.0
SL1118.I37-023-S	Stainless	0.23	3/8-16	2.00	1.31	0.56	0.13	0.75	0.14	0.75	3.75	22.5
SL1118.I50-031-S	Stainless	0.31	1/2-13	2.11	1.25	0.75	0.15	0.93	0.19	1.00	5.00	45.0
SL1118.I62-038-S	Stainless	0.38	5/8-11	3.05	2.00	1.00	0.18	1.00	0.19	1.00	5.00	67.5



Spring Loaded Pin - Inch - Lever

locking - blackened

Spring Loaded Pins

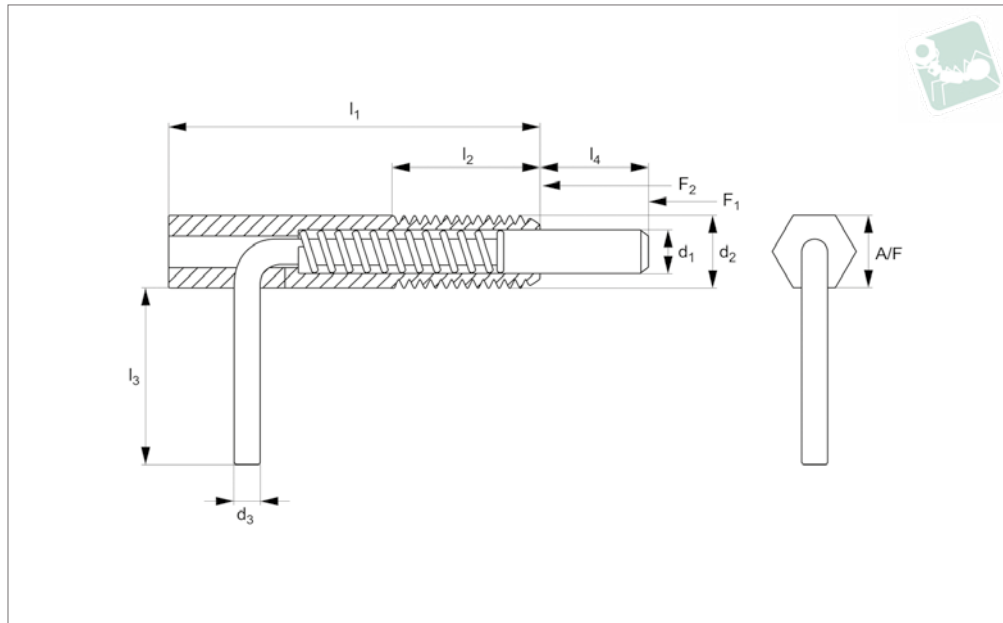

SL1119

SPRING LOADED PINS

Material

Body and pin: steel 12L14, black oxide finish.

enable pin to be held in retracted/ non-projecting position. Pull back lever, turn 90° to engage ,locking‘.

Technical Notes

Spring loaded pin can be „locked“ to

Tips

For suitable locknut, see part no. SL1816.

Order No.	d ₁ +0.000 -0.001	d ₂ UNC	l ₁	l ₂	l ₃	l ₄	d ₃	A/F	Spring force f ₁ lb	Spring force f ₂ lb
SL1119.I25-038-C	0.155	1/4-20	1.25	0.50	0.50	0.38	0.101	1/4	0.50	2.50
SL1119.I37-056-C	0.234	3/8-16	2.00	1.00	0.74	0.56	0.134	3/8	0.75	3.75
SL1119.I50-031-C	0.313	1/2-13	2.11	1.11	1.00	0.75	0.188	1/2	1.00	5.00



SL1218

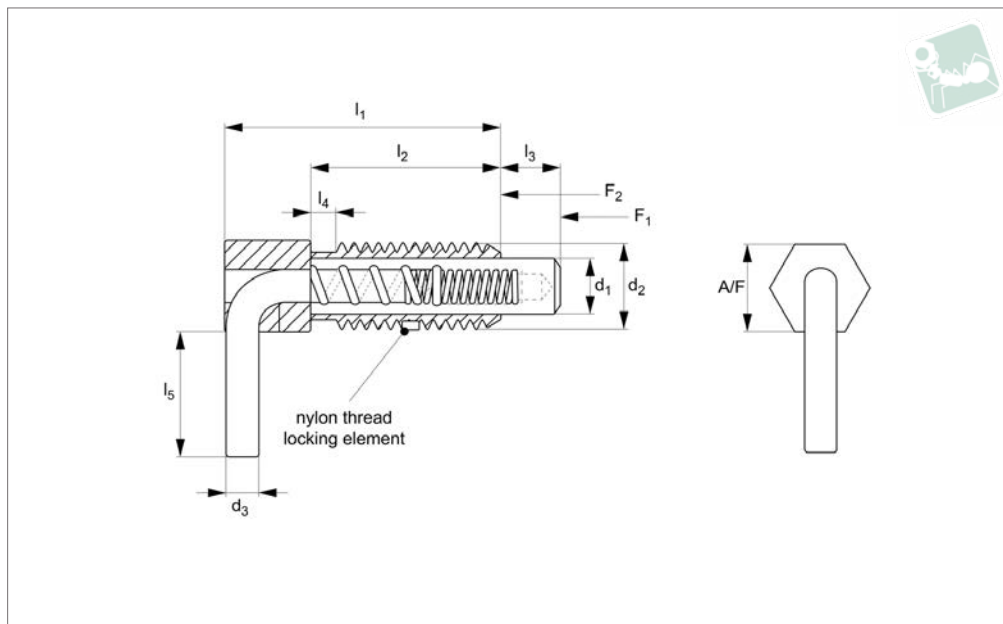

Material

Body and pin: steel 12L14, zinc plate clear chromate finish.

enable pin to be held in retracted/ non-projecting position. Pull back lever, turn 90° to engage ,locking’.

Tips

stubby version, for space limited applications.

Technical Notes

Spring loaded pin can be „locked“ to

A nylon locking element on thread reduces chance of loosening of thread due to vibration etc.

For suitable locknut, see part no. SL1816.

Order No.	d ₁	d ₂ UNC	l ₁	l ₂	l ₃	l ₄	l ₅	d ₃	A/F	Spring force f ₁ lb	Spring force f ₂ lb
SL1218.I25-016-C	0.16	1/4-20	0.75	0.50	-	0.20	0.40	0.09	0.25	0.12	0.50
SL1218.I37-025-C	0.25	3/8-16	1.13	0.75	0.13	0.30	0.56	0.14	0.38	0.25	1.25
SL1218.I50-031-C	0.31	1/2-13	1.50	1.00	0.15	0.40	0.75	0.19	0.50	0.50	2.00
SL1218.I62-038-C	0.38	5/8-11	1.88	1.25	0.18	0.50	0.88	0.19	0.62	0.75	2.50



Spring Loaded Pin, Stubby - Inch - non-locking

Spring Loaded Pins

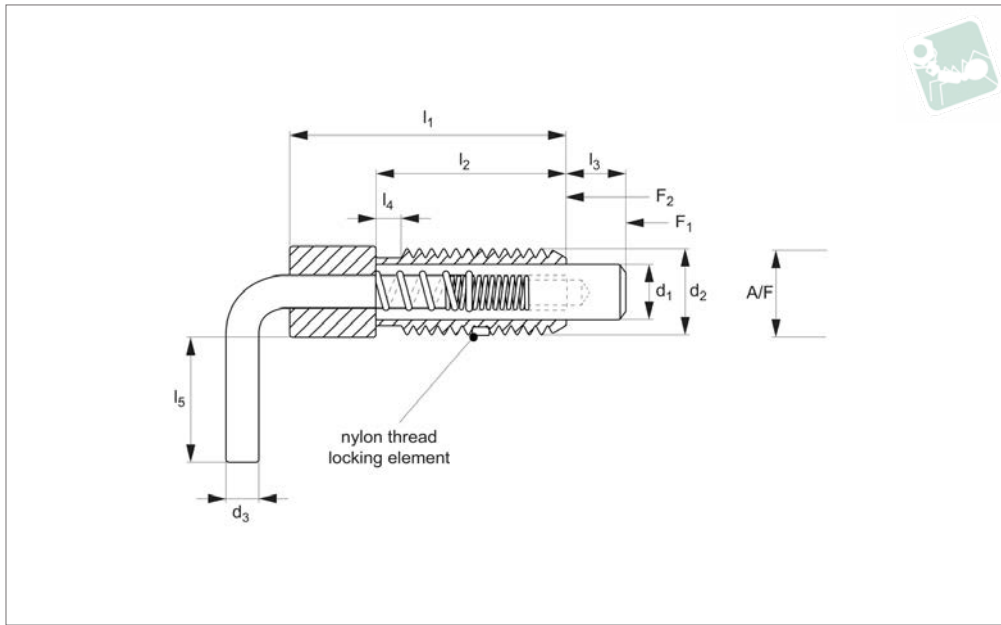

SL1216

SPRING LOADED PINS

Material

Body and pin: steel 12L14, zinc plate clear chromate finish.

simply springs back when lever released.

A nylon locking element on thread reduces chance of loosening of thread due to vibration etc.

Tips

Stubby version, for space limited applications.

For suitable locknut, see part no. SL1816.

Technical Notes

Spring loaded pin is non-locking, pin

Order No.	d_1	d_2 UNC	l_1	l_2	l_3	l_4	l_5	d_3	A/F	Spring force f_1 lb	Spring force f_2 lb
SL1216.I25-016-C	0.16	1/4-20	0.75	0.50	0.20	-	0.40	0.09	0.25	0.12	0.50
SL1216.I37-025-C	0.25	3/8-16	1.13	0.75	0.30	0.13	0.56	0.14	0.38	0.25	1.25
SL1216.I50-031-C	0.31	1/2-13	1.50	1.00	0.40	0.15	0.75	0.19	0.50	0.50	2.00
SL1216.I62-038-C	0.38	5/8-11	1.88	1.25	0.50	0.18	0.88	0.19	0.62	0.75	2.50



SL1318

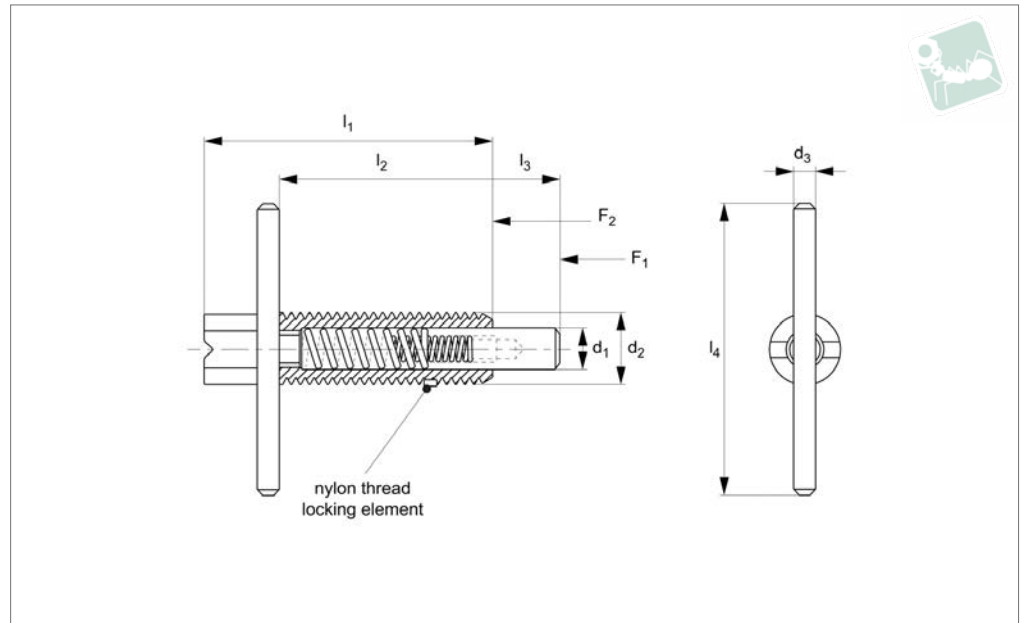

Material

Steel Type-

Body and pin: steel 12L14, zinc plate clear chromate finish.

Stainless Steel Type-

Body and pin: 300 series stainless steel.

Technical Notes

Spring loaded pin can be „locked“ to enable pin to be held in retracted/ non-projecting position. Pull back t-handle lever, turn 90° to engage ‚locking‘. T-handle provides easy to use handle for a

more positive feel.

Tips

For suitable locknut, see part no. SL1816.

Order No.	Material	d ₁	d ₂ UNC	l ₁	l ₂	l ₃	l ₄	d ₃	Spring force f ₁ lb	Spring force f ₂ lb
SL1318.I25-015-C	Steel	0.15	1/4-20	1.14	0.8	0.250	1.13	0.13	1.0	2.5
SL1318.I37-023-C	Steel	0.23	3/8-16	1.68	1.2	0.375	1.50	0.13	2.0	4.0
SL1318.I50-031-C	Steel	0.31	1/2-13	2.00	1.4	0.500	2.00	0.16	2.0	5.0
SL1318.I62-037-C	Steel	0.37	5/8-11	2.38	1.7	0.625	2.50	0.19	2.5	5.0
SL1318.I25-015-S	Stainless	0.15	1/4-20	1.14	0.8	0.250	1.13	0.13	1.0	2.5
SL1318.I37-023-S	Stainless	0.23	3/8-16	1.68	1.2	0.375	1.50	0.13	2.0	4.0
SL1318.I50-031-S	Stainless	0.31	1/2-13	2.00	1.4	0.500	2.00	0.16	2.0	5.0
SL1318.I62-037-S	Stainless	0.37	5/8-11	2.38	1.7	0.625	2.50	0.19	2.5	5.0