

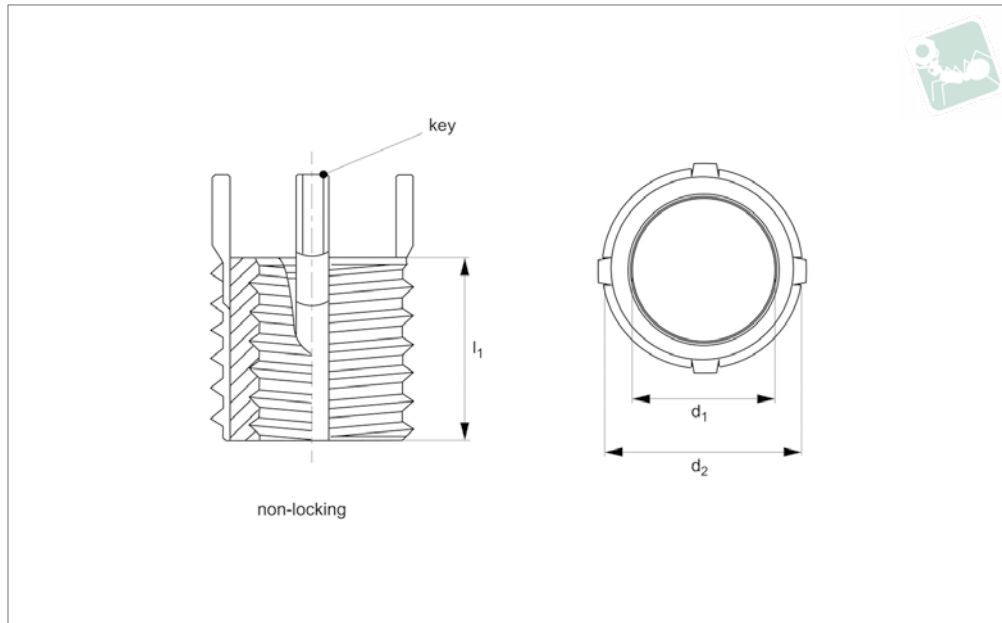

Threaded Insert MS/NAS - Thinwall - 303 stainless steel - non-locking - MS/NAS grade



TR1602

THREADED INSERTS STAINLESS

Material

Inserts - 303 CRES.
Keys - 302 CRES.
Passivated. Dry film lubrication on self-locking inserts only.

Technical Notes

All dimensions in millimetres.
Internal threads: to Fed. Std. H28/21, MJ Form

General tolerances -

+/- 0,25mm, unless specified.
Tap drill hole tolerances -
6,9 to 10,8 = +0,100/-0,025
12,8 and over = +0,130/-0,025
NL = Non-Locking type.

Tips

Order installation tool separately, as identified by „Inst. Tool ref.“ in table.

Important Notes

Four locking keys on internal threads M 6 and over. Two locking keys on internal threads smaller than M 6.
Installation (Inst.) drill size, counter sink, thread tap and thread depth as specified in table.
Removal (Rem.) drill size and drill depth as specified in table.

Order No.	Type	d ₁ tol. 4H type 5H	Thread d ₁	d ₂ tol. 4h type	Thread d ₂	Inst. tap drill size	l ₁	l ₄ c'bore depth	C'sink hole size +0.25 -0.00	Inst. thread tap tol. 6H	Inst. thread tap depth min.	Inst. tool ref. TR1712	Removal drill depth	Removal drill size
TR1602.76351	NL	M 5x0,8	Coars e	M 8x1,25	Coars e	6.90	8.0	1.27	8.25	M 8x1,25	9.5	.0510	4.00	5.50
TR1602.76551	NL	M 5x0,5	Fine	M 8x1,25	Coars e	6.90	8.0	1.27	8.25	M 8x1,25	9.5	.0510	4.00	5.50
TR1602.76352	NL	M 6x1,0	Coars e	M10 x1,25	Fine	8.80	10.0	1.78	10.25	M10x1,25	11.5	.0520	4.75	7.50
TR1602.76552	NL	M 6x0,75	Fine	M10 x1,25	Fine	8.80	10.0	1.78	10.25	M10x1,25	11.5	.0520	4.75	7.50
TR1602.76353	NL	M 8x1,25	Coars e	M12 x1,25	Fine	10.80	12.0	1.78	12.25	M12.1,25	13.5	.0530	4.75	9.50
TR1602.76553	NL	M 8x1,0	Fine	M12 x1,25	Fine	10.80	12.0	1.78	12.25	M12.1,25	13.5	.0530	4.75	9.50
TR1602.76355	NL	M10 x1,5	Coars e	M14 x1,5	Fine	12.80	14.0	2.29	14.25	M14x1,5	15.5	.0550	4.75	11.50
TR1602.76555	NL	M10 x1,25	Fine	M14 x1,5	Fine	12.80	14.0	2.29	14.25	M14x1,5	15.5	.0550	4.75	11.50



Order No.	Type	d ₁ tol. 4H 5H	Thread type d ₁	d ₂ tol. 4h	Thread type d ₂	Inst. tap drill size	l ₁	l ₄ c'bore depth	C'sink hole size +0.25 -0.00	Inst. thread tap tol. 6H	Inst. thread tap depth min.	Inst. tool ref. TR1712	Removal drill depth	Removal drill size
TR1602.76356	NL	M12 x1,75	Coarse	M16 x1,5	Fine	14.75	16.0	2.29	16.25	M16x1,5	17.5	.0560	4.75	13.50
TR1602.76556	NL	M12 x1,25	Fine	M16 x1,5	Fine	14.75	16.0	2.29	16.25	M16x1,5	17.5	.0560	4.75	13.50