

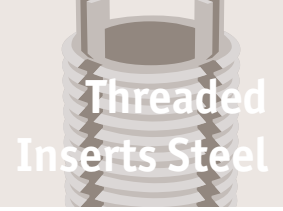

Threaded Insert MS/NAS - Mini - 4140 steel - non-locking - MS/NAS grade

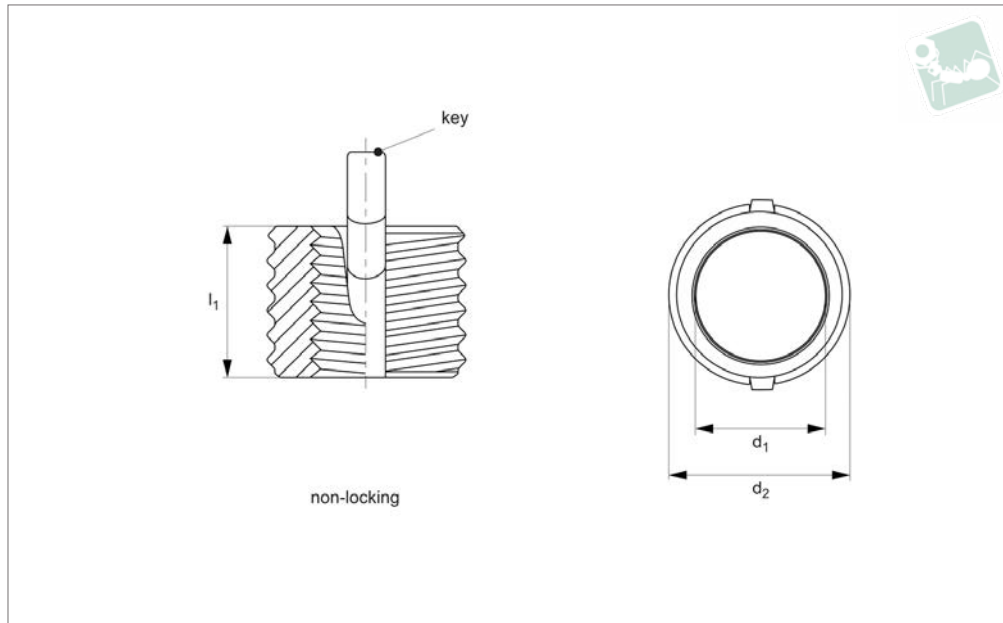

Threaded
Inserts Steel



TR1606

THREADED INSERTS STEEL

Material

Inserts - 4140 alloy steel (160 KSI Min).
Keys - 302 CRES.
Cadmium plate (QQ-P-416 Type II, Cl. 2).
Dry film lubrication on self-locking inserts only.

Technical Notes

All dimensions in millimetres.
Internal threads: to Fed. Std. H28/21, MJ Form

General tolerances -

+/- 0,25mm, unless specified.
Tap drill hole tolerances -
6,9 to 10,8 = +0,100/-0,025
12,8 and over = +0,130/-0,025
NL = Non-Locking type.

Tips

Order installation tool separately, as identified by „Inst. Tool ref.“ in table.

Important Notes

Four locking keys on internal threads M6 and over. Two locking keys on internal threads smaller than M6.
Installation (Inst.) drill size, counter sink, thread tap and thread depth as specified in table.
Removal (Rem.) drill size and drill depth as specified in table.
Perform to standards: NA0148

Order No.	Type	d ₁ tol. 4H 6H	Thread type d ₁	d ₂ tol. 4h	Thread type d ₂	l ₁	Inst. c'sink hole size +0.25 - 0.00	Inst. tap drill size +0.080 -0.025	Inst. thread tap tol. 6H	Inst. thread tap depth min.	Inst. tool ref. TR1710	Removal drill size	Removal drill depth
TR1606.80382	NL	M 2x0,4	Coarse	M 4x0,7	Coarse	3,00	4,1	3,4	M 4x0,7	4,0	.0820	2,8	2,00
TR1606.80383	NL	M2,5x0,45	Coarse	M4,5x0,75	Coarse	3,81	4,6	3,9	M4,5x0,75	5,0	.0830	3,0	2,00
TR1606.80384	NL	M 3x0,5	Coarse	M 5x0,8	Coarse	4,25	5,1	4,4	M 5x0,8	5,5	.0840	3,5	2,25
TR1606.80386	NL	M 4x0,7	Coarse	M 6x0,75	Fine	5,25	6,1	5,5	M 6x0,75	6,5	.0860	4,6	2,50