

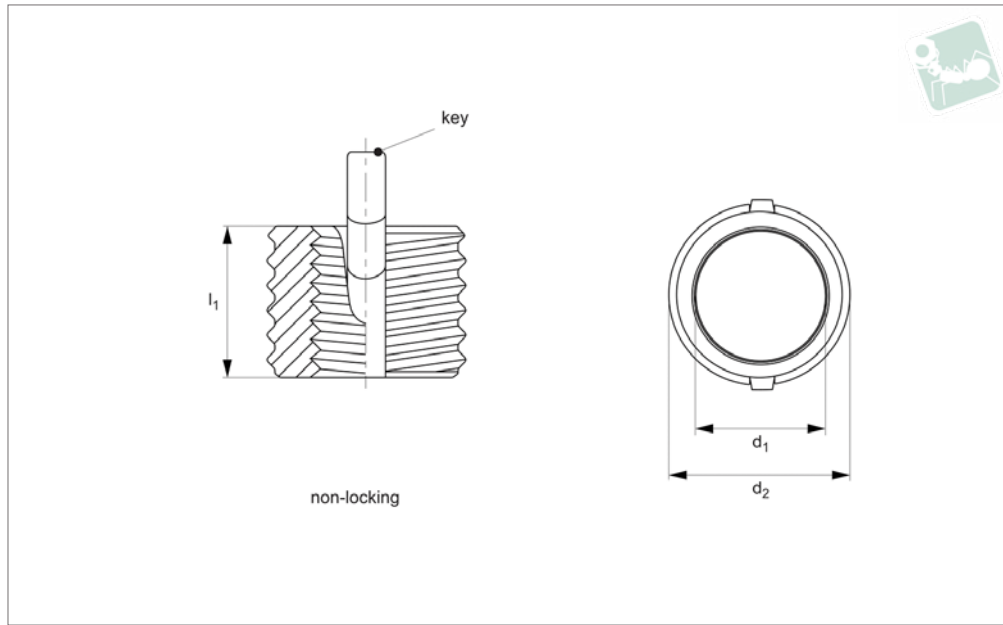

Threaded Insert MS/NAS - Mini - 303 stainless steel - non-locking - MS/NAS grade



TR1600

THREADED INSERTS STAINLESS

Material

Inserts - 303 CRES.
Keys - 302 CRES.
Passivated. Dry film lubrication on self-locking inserts only.

General tolerances -

+/- 0,25mm, unless specified.
Tap drill hole tolerances -
6,9 to 10,8 = +0,100/-0,025
12,8 and over = +0,130/-0,025
NL = Non-Locking type.

Important Notes

Four locking keys on internal threads M6 and over. Two locking keys on internal threads smaller than M6.
Installation (Inst.) drill size, counter sink, thread tap and thread depth as specified in table.
Removal (Rem.) drill size and drill depth as specified in table.

Technical Notes

All dimensions in millimetres.
Internal threads: to Fed. Std. H28/21, MJ Form

Tips

Order installation tool separately, as identified by „Inst. Tool ref.“ in table.

Order No.	Type	d ₁ tol. 4H 6H	Thread type d ₁	d ₂ tol. 4h	Thread type d ₂	l ₁	Inst. c'sink hole size +0.25 -0.00	Inst. tap drill size +0.080 - 0.025	Inst. tap to depth min.	Inst. thread tap tol. 6H	Inst. tool ref. TR1710	Removal drill size	Removal drill depth
TR1600.76382	NL	M 2x0, 4	Coarse	M 4x0, 7	Coarse	3.00	4.1	3.4	4.0	M 4x0,7	.0820	2.8	2.00
TR1600.76383	NL	M2,5 x0,4 5	Coarse	M4,5 x0,7 5	Coarse	3.81	4.6	3.9	5.0	M4,5x0 ,75	.0830	3.0	2.00
TR1600.76384	NL	M 3x0, 5	Coarse	M 5x0, 8	Coarse	4.25	5.1	4.4	5.5	M 5x0,8	.0840	3.5	2.25
TR1600.76386	NL	M 4x0, 7	Coarse	M 6x0, 75	Fine	5.25	6.1	5.5	6.5	M 6x0,75	.0860	4.6	2.50



TR1601

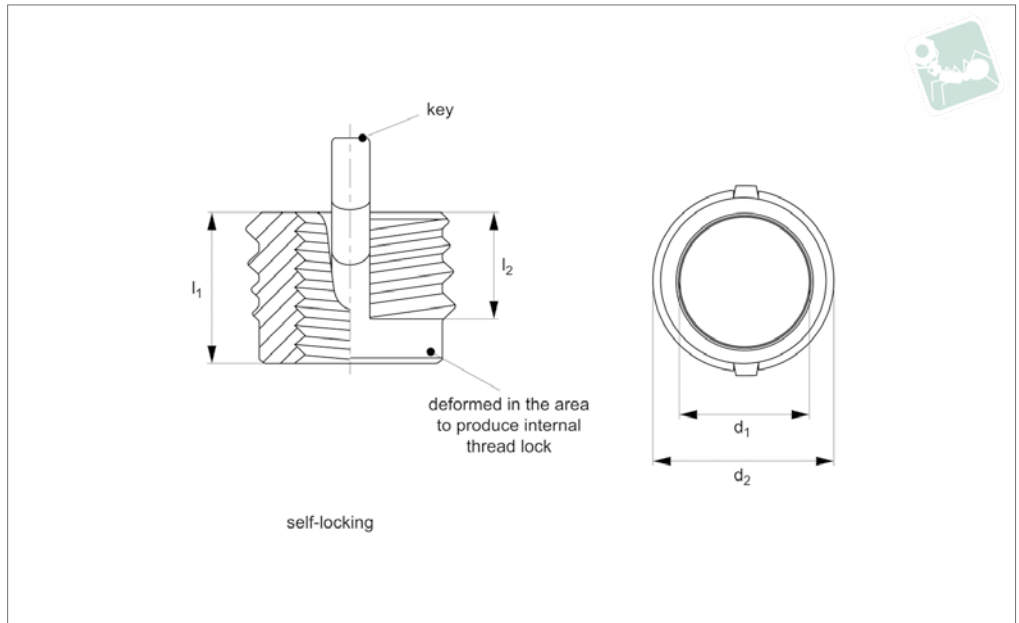

Material

Inserts - 303 CRES.
Keys - 302 CRES.
Passivated. Dry film lubrication on self-locking inserts only.

Technical Notes

All dimensions in millimetres.
Internal threads: to Fed. Std. H28/21, MJ Form
General tolerances -

+/- 0,25mm, unless specified.

Tap drill hole tolerances -
6,9 to 10,8 = +0,100/-0,025
12,8 and over = +0,130/-0,025

SL = Self-Locking type, deliberate deformity in thread produces self-affect once installed (see technical diagram).

Tips

Order installation tool separately, as identified by „Inst. Tool ref.“ in table.

Important Notes

Four locking keys on internal threads M6 and over. Two locking keys on internal threads smaller than M6.

Installation (Inst.) drill size, counter sink, thread tap and thread depth as specified in table.

Removal (Rem.) drill size and drill depth as specified in table.

Order No.	Type	d ₁ tol. 4H 6H	Thread type d ₁	d ₂ tol. 4h	Thread type d ₂	l ₁	l ₂	Inst. c'sink hole size +0.25 -0.00	Inst. tap drill size +0.080 -0.025	Inst. tap to depth min.	Inst. thread tap tol. 6H	Inst. tool ref. TR1710	Removal drill size	Removal drill depth
TR1601.77382	SL	M 2x0, 4	Coarse	M 4x0, 7	Coarse	3.00	2.20	4.1	3.4	4.0	M 4x0,7	.0820	2.8	2.00
TR1601.77383	SL	M2,5 x0,4 5	Coarse	M4,5 x0,7 5	Coarse	3.81	2.70	4.6	3.9	5.0	M4,5x 0,75	.0830	3.0	2.00
TR1601.77384	SL	M 3x0, 5	Coarse	M 5x0, 8	Coarse	4.25	3.10	5.1	4.4	5.5	M 5x0,8	.0840	3.5	2.25
TR1601.77386	SL	M 4x0, 7	Coarse	M 6x0, 75	Fine	5.25	4.11	6.1	5.5	6.5	M 6x0,75	.0860	4.6	2.50



Threaded Insert MS/NAS - Mini - Inch

303 stainless steel - non-locking - MS/NAS grade

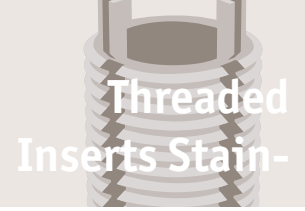

Threaded Inserts Stain-

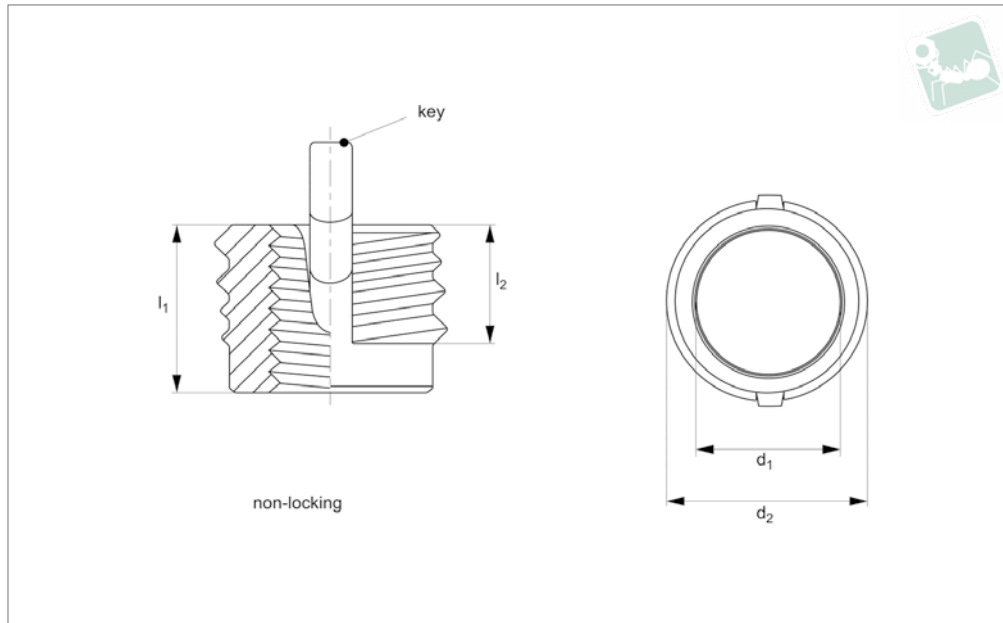

TR1650

THREADED INSERTS STAINLESS

Material

Inserts - 303 CRES.
Keys - 302 CRES.
Passivated. Dry film lubrication on self-locking inserts only.

Technical Notes

All dimensions in inches.
Internal threads: to SAE AS8879.
General tolerances -
+/- 0,010 unless specified.

Tap drill hole tolerances -
0,234 to 0,500 = +0,004/-0,001
0,500 and over = +0,005/-0,001
NL = Non-Locking type.

Tips

Order installation tool separately, as identified by „Inst. Tool ref.“ in table.

Important Notes

Four locking keys on internal threads 5/16

and over. Two locking keys on internal threads smaller than 5/16.
Installation (Inst.) drill size, counter sink, thread tap and thread depth as specified in table.
Removal (Rem.) drill size and drill depth as specified in table.
Perform to standards: MIL-I-45914A (MS51830)
* Modified minor dia.

Order No.	Type	d ₁ tol. 3B type	Thread d ₁	d ₂ tol. 2A type	Thread d ₂	l ₁	l ₂	C'sink hole size	Inst. tap drill size +0.00 0 - 0.001	Inst. thread tap depth min.	Inst. thread tap size tol. 6B	Inst. tool ref. TR1700	Removal drill size	Removal drill depth
TR1650.76283	NL	2-56	UNC	8-32	UNC	.120	.090	.166	.134	.140	8-32	.0830	#33	1/16
TR1650.76284	NL	4-40	UNC	10-32	UNF	.170	.125	.194	.161	.160	10-32	.0840	#29	3/32
TR1650.76285	NL	6-32	UNC	12-28	UNF	.170	.125	.220	.187	.160	12-28	.0850	#21	3/32
TR1650.76286	NL	8-32	UNC	1/4-28*	UNF	.220	.175	.255	.228	.210	1/4-28	.0860	#8	1/8



TR1651

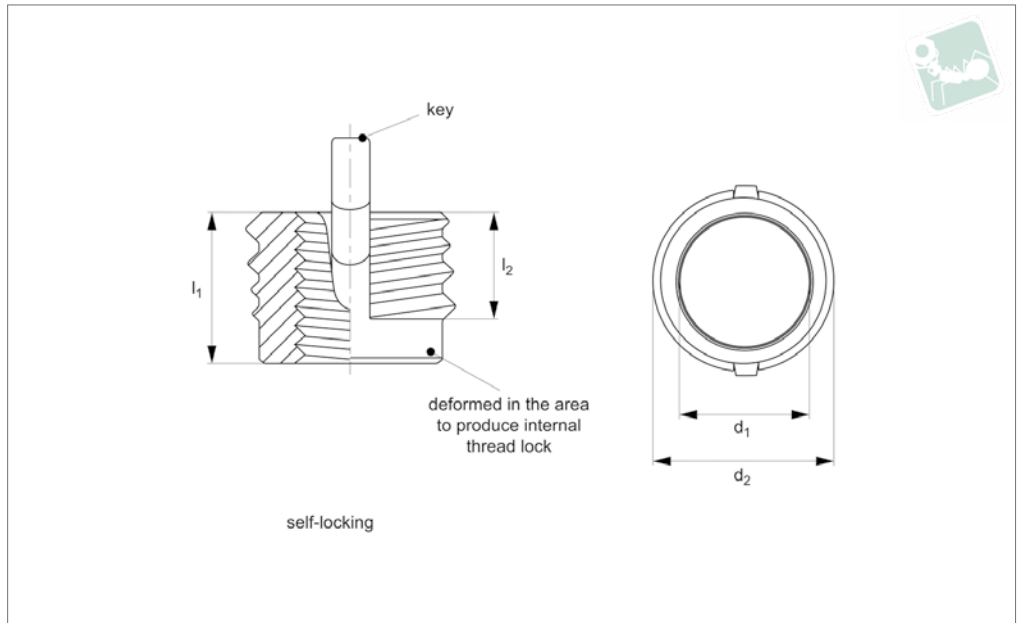

Material

Inserts - 303 CRES.
Keys - 302 CRES.
Passivated. Dry film lubrication on self-locking inserts only.

Technical Notes

All dimensions in inches.
Internal threads: to SAE AS8879.
General tolerances -
+/- 0,010 unless specified.
Tap drill hole tolerances -

0,234 to 0,500 = +0,004/-0,001
0,500 and over = +0,005/-0,001
SL = Self-Locking type, deliberate deformity in thread produces self-affect once installed (see technical diagram).

Tips

Order installation tool separately, as identified by „Inst. Tool ref.“ in table.

Important Notes

Four locking keys on internal threads 5/16

and over. Two locking keys on internal threads smaller than 5/16.
Installation (Inst.) drill size, counter sink, thread tap and thread depth as specified in table.
Removal (Rem.) drill size and drill depth as specified in table.
Perform to standards: MIL-I-45914A (MS51830)
* Modified minor dia.

Order No.	Type	d ₁ tol. 3B type	Thread d ₁	d ₂ tol. 2A type	Thread d ₂	l ₁	l ₂	C'sink hole size	Inst. tap drill +0.00 3 -0.001	Inst. thread tap depth min.	Inst. thread tap size tol. 6B	Inst. tool ref. TR1700	Removal drill size	Removal drill depth
TR1651.77283	SL	2-56	UNC	8-32	UNC	.120	.090	.166	.134	.140	8-32	.0830	#33	1/16
TR1651.77284	SL	4-40	UNC	10-32	UNF	.170	.125	.194	.161	.160	10-32	.0840	#29	3/32
TR1651.77285	SL	6-32	UNC	12-28	UNF	.170	.125	.220	.187	.160	12-28	.0850	#21	3/32
TR1651.77286	SL	8-32	UNC	1/4-28*	UNF	.220	.175	.255	.228	.210	1/4-28	.0860	#8	1/8



Blind Threaded Insert - Mini - Inch

303 stainless steel - non-locking

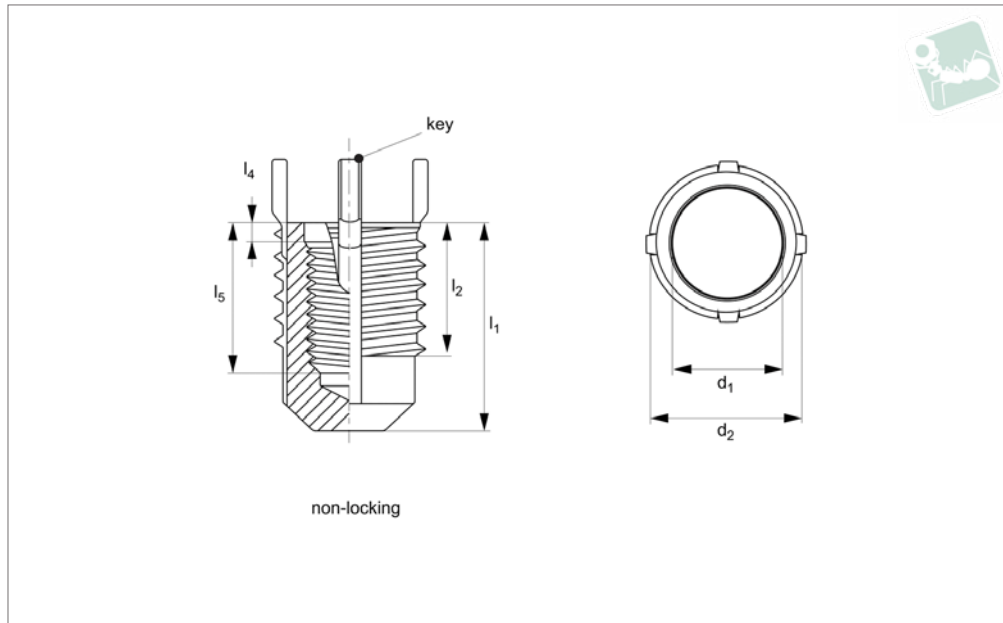
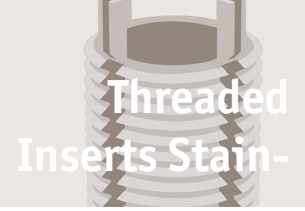

TR1670

THREADED INSERTS STAINLESS

Material

Inserts - A303 CRES.
 Keys - 302 CRES.
 Passivated. Dry film lubrication on self-locking inserts only.

Technical Notes

All dimensions in inches.
 Internal threads: to SAE AS8879.
 General tolerances -
 +/- 0,010 unless specified.

Tap drill hole tolerances -
 0,234 to 0,500 = +0,004/-0,001
 0,500 and over = +0,005/-0,001
NL = Non-Locking type.

Tips

Order installation tool separately, as identified by „Inst. Tool ref.“ in table.

Important Notes

Four locking keys on internal threads 5/16

and over. Two locking keys on internal threads smaller than 5/16.
 Installation (Inst.) drill size, counter sink, thread tap and thread depth as specified in table.
 Removal (Rem.) drill size and drill depth as specified in table.
 Perform to standards: MIL-I-45914A

Order No.	Type	d ₁ tol. 3B	Thre ad type d ₁	d ₂ tol. 2A	Thre ad type d ₂	l ₁	l ₂	l ₄ c'bore depth	l ₅	Inst. c'sink hole size +0.010 -0.000	Inst. tap drill size	Inst. thread tap depth min.	Inst. thread tap size class 2B	Inst. tool ref. TR1700	Remo val drill size	Removal drill depth
TR1670.83290	NL	2-56	UNC	8-32	UNC	.24	.18	C'Sin k	.13	.166	.134	.24	8-32	.0830	#33	1/16
TR1670.83291	NL	4-40	UNC	10-32	UNF	.31	.22	C'Sin k	.17	.194	.161	.28	10-32	.0840	#29	3/32
TR1670.83292	NL	6-32	UNC	12-28	UNF	.39	.22	C'Sin k	.21	.220	.187	.28	12-28	.0850	#21	3/32
TR1670.83294	NL	8-32	UNC	1/4-28	UNF	.43	.24	C'Sin k	.25	.255	.228	.30	1/4-28	.0860	#8	3/32



TR1671

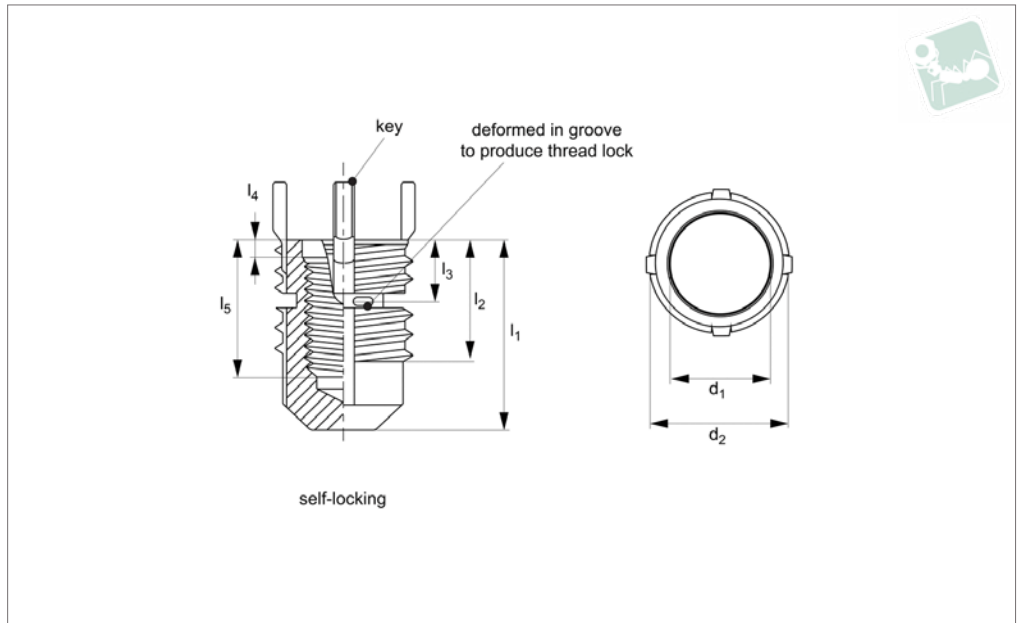

Material

Inserts - A303 CRES.
Keys - 302 CRES.
Passivated. Dry film lubrication on self-locking inserts only.

Technical Notes

All dimensions in inches.
Internal threads: to SAE AS8879.
General tolerances -
+/- 0,010 unless specified.

Tap drill hole tolerances -

0,234 to 0,500 = +0,004/-0,001
0,500 and over = +0,005/-0,001
SL = Self-Locking type, deliberate deformity in thread produces self-affect once installed (see technical diagram).

Tips

Order installation tool separately, as identified by „Inst. Tool ref.“ in table.

Important Notes

Four locking keys on internal threads 5/16 and over. Two locking keys on internal threads smaller than 5/16.
Installation (Inst.) drill size, counter sink, thread tap and thread depth as specified in table.
Removal (Rem.) drill size and drill depth as specified in table.
Perform to standards: MIL-I-45914A

Order No.	Type	d ₁ tol. 3B	Thre ad type d ₁	d ₂ tol. 2A	Thre ad type d ₂	l ₁	l ₂	l ₃ ±0.0 30	l ₄ c'bore depth	l ₅	Inst. c'sink hole size +0.010 -0.000	Inst. tap drill size	Inst. thread tap depth min.	Inst. thread tap size class 2B	Inst. tool ref. TR1700	Rem oval drill size	Removal drill depth size
TR1671.84290	SL	2-56	UNC	.166	UNC	.24	.18	.10	C'Sin k	.13	.166	.134	.24	8-32	.0830	#33	1/16
TR1671.84291	SL	4-40	UNC	.194	UNF	.31	.22	.12	C'Sin k	.17	.194	.161	.28	10-32	.0840	#29	3/32
TR1671.84292	SL	6-32	UNC	.220	UNF	.39	.22	.12	C'Sin k	.21	.220	.187	.28	12-28	.0850	#21	3/32
TR1671.84294	SL	8-32	UNC	.255	UNF	.43	.24	.13	C'Sin k	.25	.255	.228	.30	1/4-28	.0860	#8	3/32